

MASTERVOLT

THE POWER TO BE INDEPENDENT

MasterShunt 500

ENHANCED BATTERY MONITOR

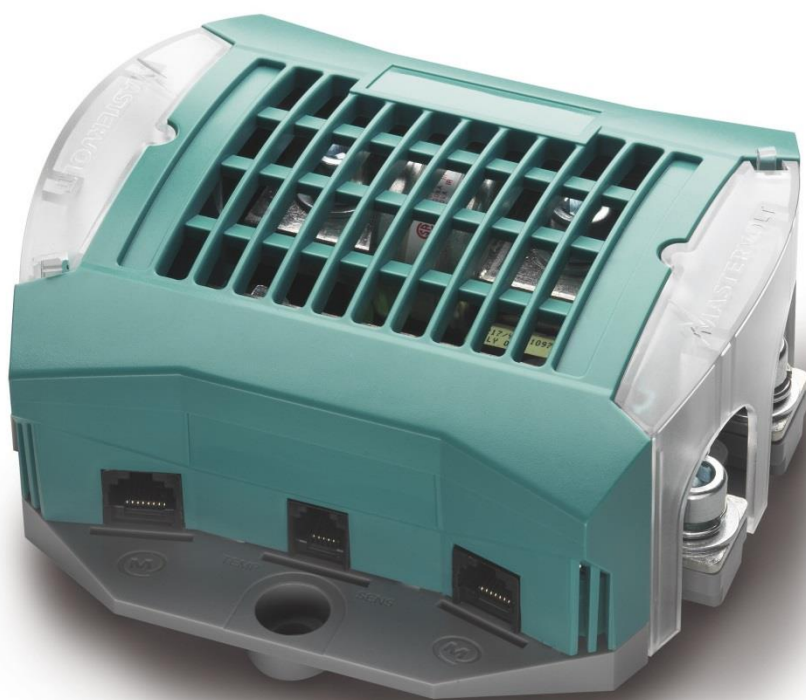

USER AND INSTALLATION MANUAL

10000011590/08

- (NL) Ga om deze handleiding in andere talen te downloaden naar onze website:
- (DE) Um diese Anleitung in anderen Sprachen herunterzuladen, besuchen Sie bitte unsere Website:
- (FR) Pour télécharger ce manuel dans d'autres langues, consultez notre site Web :
- (ES) Para descargar este manual en otros idiomas, visite nuestro sitio web:
- (IT) Per scaricare questo manuale in altre lingue, visitare la pagina del prodotto sul nostro sito Web:

www.mastervolt.com

TABLE OF CONTENTS

1	GENERAL INFORMATION	3
1.1	Use of this manual.....	3
1.2	Liability	3
1.3	Warranty.....	3
1.4	Disclaimer.....	3
1.5	Identification label.....	3
1.6	Correct disposal of this product	3
2	SAFETY INSTRUCTIONS	4
2.1	Use for intended purpose	4
2.2	Maintenance and repair	4
2.3	General safety and installation precautions	4
2.4	Warning regarding battery use	4
3	PRODUCT DESCRIPTION	5
3.1	Introduction.....	5
3.2	Exterior	5
3.3	LED indicators	5
4	Installation	6
4.1	Things you need for installation	6
4.2	Connection example.....	6
4.3	Installation step-by-step.....	7
4.4	Placing a fuse inside.....	8
4.5	Parallel use (MasterBus only).....	10
5	SETTINGS	11
5.1	About MasterBus	11
5.1.1	Configuration	11
5.1.2	Events – System Automation.....	14
5.1.3	Alarms	15
5.1.4	Monitoring.....	15
5.1.5	History	16
5.2	About CZone	17
6	MAINTENANCE	19
6.1	Replacement of batteries / reset history	19
6.2	Replacement of a fuse.....	19
7	Trouble shooting	20
8	Specifications	21
8.1	Technical specifications.....	21
8.2	Dimensions.....	22

1 GENERAL INFORMATION

1.1 Use of this manual

This manual serves as a guideline for the safe and effective operation and maintenance of the following MasterShunt 500 models:

Product code	Model
77020110	MasterShunt 500 – MasterBus only
77020115	MasterShunt 500 – CZone and MasterBus

These models are further referred to as “MasterShunt 500”.

1.2 Liability

Advanced Systems Group cannot be held liable for:

- Consequential damage resulting from the use of the MasterShunt 500.
- Possible errors in the included manual and the consequences of these.
- Use that is inconsistent with the purpose of the product.

1.3 Warranty

Advanced Systems Group assures the product warranty of the MasterShunt 500 during two years after purchase, on the condition that the product is installed and used according to the instructions in this manual.

Installation or use not according to these instructions may result in under performance, damage or failure of the product and may void this warranty. The warranty is limited to the cost of repair and/or replacement of the product. Costs for labour or shipping are not covered by this warranty.

1.4 Disclaimer

Our products are subject to continual development and improvement. Therefore, additions or modifications to the products may cause changes to the technical data and functional specifications. No rights can be derived from this document. Please consult our most current Terms & Conditions of Sale.

1.5 Identification label

The following picture is only an example!

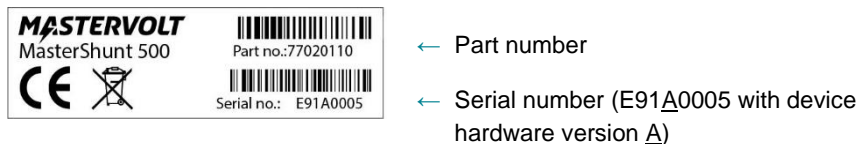

CAUTION!
Never remove the identification label.

Figure 1: Identification label

Important information required for service or maintenance can be derived from the identification label. The identification label is located at the bottom of the MasterShunt 500.

1.6 Correct disposal of this product



This product is designed and manufactured with high quality materials and components, which can be recycled and reused. When this crossed-out wheeled bin symbol is attached to a product, it means the product is covered by the European Directive 2012/19/EU.

Please be informed about the local separate collection system for electrical and electronic products. Please act according to your local rules and do not dispose of your old products with your normal household waste. The correct disposal of your old product will help prevent potential negative consequences to the environment and human health

2 SAFETY INSTRUCTIONS



WARNING!

Read the entire manual before using the MasterShunt 500. Keep this manual in a secure place.

Installation and work on the MasterShunt 500 may be carried out only by qualified and trained personnel, consistent with the locally applicable standards and taking into consideration the safety guidelines and measures.

2.1 Use for intended purpose

The MasterShunt 500 is constructed according to applicable safety guidelines.

Use the MasterShunt 500 only:

- in a technical correct condition;
- in a closed, well-ventilated room, protected against rain, moist, dust and condensation;
- observing the instructions in the user manual.



WARNING!

Never use the MasterShunt 500 in locations where there is danger of gas or dust explosion or potentially flammable products.

2.2 Maintenance and repair

If the electrical installation is switched off during maintenance and/or repair activities, it should be secured against unexpected and unintentional switching on:

- switch off all charging systems;
- switch off the connection with the batteries;
- be sure that third parties cannot reverse the measures taken.

If maintenance and repairs are required, only use original spare parts.

2.3 General safety and installation precautions

- Connection and protection must be done in accordance with local standards.
- Do not work on the MasterShunt 500 or system if it is still connected to a current source. Only allow changes in your electrical system to be carried out by qualified electricians.
- Check the wiring at least once a year. Defects such as loose connections, burned cables etc. must be corrected immediately.

2.4 Warning regarding battery use

Excessive battery discharge and/or high charging voltages can cause serious damage to batteries. Do not exceed the recommended limits of battery discharge level. Avoid short circuiting batteries, as this may result in explosion and fire hazard.

3 PRODUCT DESCRIPTION

3.1 Introduction

The MasterShunt 500 is a battery monitor that enables system automation and also provides power to the MasterBus network. The battery bank is monitored in the most accurate way by measuring the voltage and the (dis)charge current through a shunt. The extended information about the status of a battery bank includes voltage, current, State Of Charge (SOC) and indication of the time remaining.

The SOC is expressed as a percentage. This value is automatically compensated by the charge efficiency factor (C.E.F.) and the Peukert exponent. When the battery is fully charged, the SOC will be reset to 100%. A non Li-ion battery is considered to be fully charged if one of the following conditions is met.

- 1 Parameters below are met for at least 30 seconds:
 - All the Ah's discharged are charged back into the battery (real counting without CEF).
 - The actual charge current is less than the setting for charge amps for full battery but more than 0A.
- 2 For at least 4 hours the battery voltage is higher than the float voltage *plus* 1.0/2.0/3.0/4.0V (at nominal battery voltage 12/24/36/48V).
- 3 For at least 8 hours the battery voltage is higher than the float voltage *plus* 0.3/0.6/0.9/1.2V (at nominal battery voltage 12/24/36/48V).
- 4 For at least 12 hours the battery voltage is higher than the float voltage *minus* 0.1/0.2/0.3/0.4V (at nominal battery voltage 12/24/36/48V).

A display like the Touch 10 (in a CZone network) or the EasyView 5 (in a MasterBus network) can be used to show the battery information.

3.2 Exterior

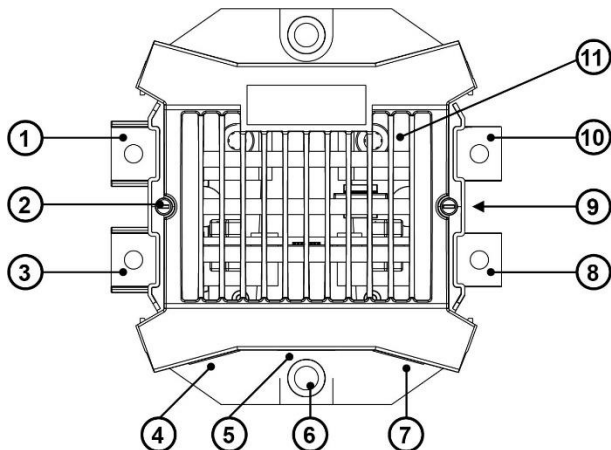

1. Positive battery pole at battery side
2. Fastening screw, on both sides (turn 90 degrees to loosen top)
3. Negative battery pole at battery side
4. CZone/MasterBus connector
5. Temperature sensor connector
6. Mounting hole for M8 socket screw
7. CZone/MasterBus connector
8. Negative battery pole at load side
9. Status LEDs, on both sides
10. Positive battery pole at load side
11. Bus bar or optional Internal fuse

Figure 2 : Overview of the MasterShunt

3.3 LED indicators

The MasterShunt 500 features two LED indicators; one between the connectors at the battery side and one between the connectors at the load side (item 9 in Figure 2).

Condition	Meaning
Simultaneously slow blinking	No network activity
Simultaneously irregular blinking	Network activity
Alternately fast blinking	Alarm situation

4 Installation



WARNING!

During installation and commissioning of the MasterShunt 500, the Safety Guidelines and Measures are always applicable. See Chapter 2 'Safety guidelines and measures'.



CAUTION!

Wrong connections may cause damage to the MasterShunt 500 and other equipment as well, which is not covered by warranty!

- Notes:**
- For correct measurements the MasterShunt 500 must be placed *as close as possible* to the batteries.
 - Optionally a fuse can be placed inside the MasterShunt 500 to make your installation safer, see Section 4.4. Otherwise make sure to place fuses on other places in your installation to guarantee its safety.

4.1 Things you need for installation

	77020115 (CZone & MasterBus)	77020110 (MasterBus only)
In the box:		
MasterShunt 500	✓	✓
MasterBus cable, 6m	✗	✓
RJ45-M12 Drop cable CZone/MB, 1m	✓	✗
Terminator for MasterBus network	✗	✓
Temperature sensor	✓	✓
Two translucent end pieces	✓	✓
Four DC cones	✓	✓
One translucent mid piece for easy connection to Mastervolt's DC Distribution 500.	✓	✓
Four M8 bolts with washer to fasten the DC wiring.	✓	✓

In the box:

	77020115 (CZone & MasterBus)	77020110 (MasterBus only)
In the box:		
MasterShunt 500	✓	✓
MasterBus cable, 6m	✗	✓
RJ45-M12 Drop cable CZone/MB, 1m	✓	✗
Terminator for MasterBus network	✗	✓
Temperature sensor	✓	✓
Two translucent end pieces	✓	✓
Four DC cones	✓	✓
One translucent mid piece for easy connection to Mastervolt's DC Distribution 500.	✓	✓
Four M8 bolts with washer to fasten the DC wiring.	✓	✓

Tools and materials:

- For CZone setup, a tee connector (not included)
- A crosshead screwdriver
- 2 mm flat blade screwdriver
- Hexagonal socket wrench size 6 mm (1/4")
- Two heavy duty battery cables shortest possible, finished with cable lugs. Cable thickness must be in accordance with the electrical installation
- A complete set of spanners, pliers and wrenches may be helpful during the installation of the MasterShunt 500.



CAUTION!

Use isolated tools!

4.2 Connection example

The following schematics illustrate the general placement of the MasterShunt 500 in a network. It is not meant to provide detailed wiring instructions for any particular electrical installation.

- **in a CZone network**

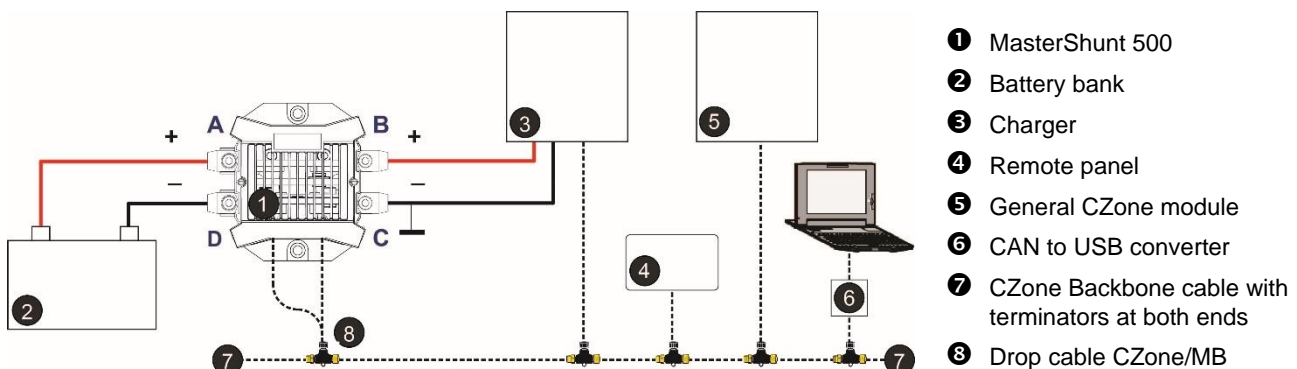

Points to consider:

- Up to 40 devices can be connected together on a single backbone.
- Make sure the CZone network has two terminating resistors, one at each open end of the backbone.
- The electric power for the network comes from a battery or power supply. Make sure that it delivers enough power and is positioned as close to the middle of the backbone as possible to reduce voltage drop.
- The CZone/MB drop cable includes a diode to prevent power from the MasterShunt 500 getting on the CZone backbone.

• in a MasterBus network

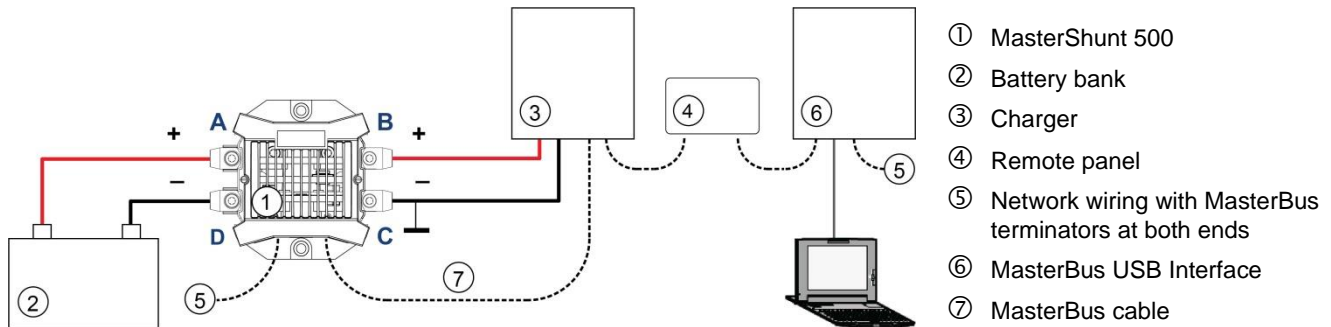

Use an RJ45 MasterBus cable (not included) and daisy chain the MasterShunt 500 to the other MasterBus devices, forming a local data network.

Points to consider:

- Connections between the devices are made by standard straight MasterBus cables. Advanced Systems Group can supply these cables.
- Up to 63 MasterBus devices can be connected together.
- MasterBus needs a terminating device on both ends of the network.
- The electric power for the network comes from the connected devices according to the rule: 1 powering / 3 non-powering. Spread the powering devices over the network
- Do not make ring networks.
- Do not make T-connections in the network.



CAUTION!

Never connect a non-MasterBus device to the MasterBus network directly! This will void warranty of all MasterBus devices connected.

For more details on networks, please contact your Mastervolt supplier.

4.3 Installation step-by-step

Step 1. Disconnect the electrical power.

- Switch off all consumers.
- Switch off all charging systems.
- Disconnect the positive battery poles.
- Check with a suitable voltmeter whether the entire DC installation is voltage free.

Step 2. Position the MasterShunt 500 close to the battery, between the battery and the load/charger.

Note: Remember to put the cones around the cables before connecting!

Step 3. Connect the loose positive battery cable to the upper left connection (A) and the positive load cable to the upper right connection (B).

Step 4. Connect the negative battery cable to (D) and the negative load cable to (C).

- Use cable lugs to accomplish sufficient electrical contact between the wiring and the MasterShunt 500.
- The recommended tightening torque is 15-20 Nm.

Note: The charger must be connected at the load side of the MasterShunt 500!



CAUTION!

Leave the positive battery cable disconnected from the battery.

Step 5. Option: place a fuse. See section 4.4.

Step 6. Option: connect the MasterShunt 500 to the CZone or MasterBus network.

Adding the MasterShunt 500 to a CZone network

- 1 Disconnect the backbone at the closest backbone connection and add in a tee connector.
- 2 Reconnect the backbone connection(s) with the new tee connector in place.
If you want to add the MasterShunt 500 at the end of the backbone, remove the terminator, add the new tee connector and attach the terminator to the side of the connector.
- 3 Connect the RJ45 CZone/MB drop cable to the black coupler on the tee and then connect to the MasterShunt 500.

Adding the MasterShunt 500 to a MasterBus network

- 1 Disconnect a MasterBus cable or Terminator from the closest MasterBus device and connect it to the MasterShunt 500.
- 2 Connect the new MasterBus cable to the other MasterBus device and then connect to the MasterShunt 500.
- 3 Ensure that the network is properly terminated.

See section 4.2 for more information on system integration.

Step 7. Check all wiring. If all wiring is OK: (re)connect the positive battery cable.

Step 8. Proceed with chapter 5, SETTINGS.

4.4 Placing a fuse inside

By default, the MasterShunt 500 is equipped with a busbar inside. If the MasterShunt 500 is installed close to the battery, this busbar may be replaced by either an ANL type or a Class T main fuse (450A or 500A), saving both space and cost. Another option is to place a fuse elsewhere in the system.

Note: Always have the selected fuse checked by qualified personnel to prevent any unnecessary fuse melts when going fully operational.

Execute the following procedure to replace the busbar by a fuse:

Step 1. Disconnect the electrical power:

Step 2. Remove the two transparent covers.

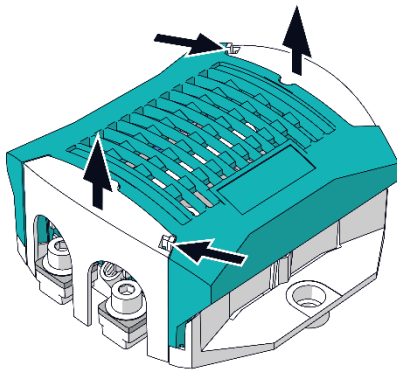

Step 3. Unlock and remove upper casing.

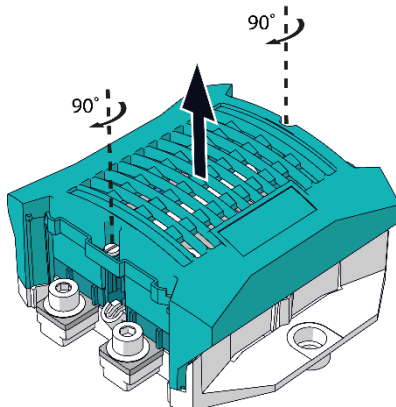

Step 4. Remove the two bolts.

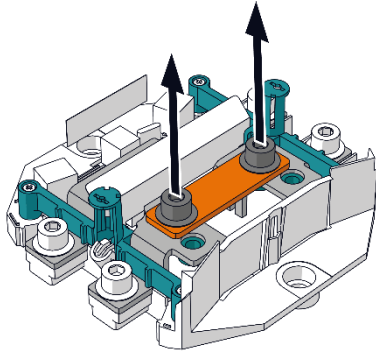

Step 5. Take out the busbar. Mind possible hot parts!

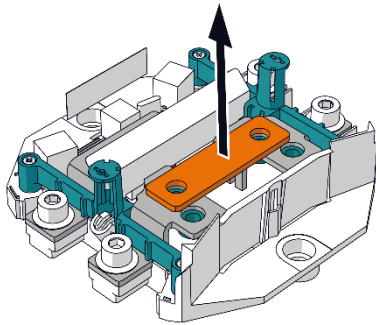

Step 6. Place a class T-fuse or an ANL fuse and fasten with the two removed bolts from step 4 (torque 15-20 Nm).

T-Fuse

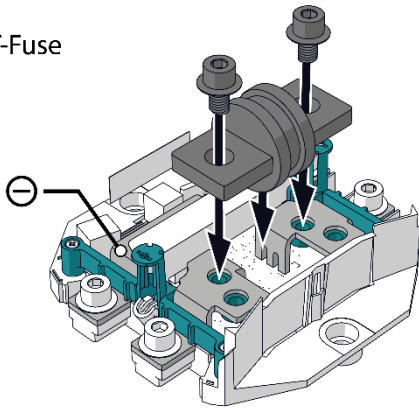

WARNING!

When installing the T-fuse, make sure it does not make any contact with the negative pole inside the MasterShunt 500, see ⊖ in the drawing.

ANL fuse

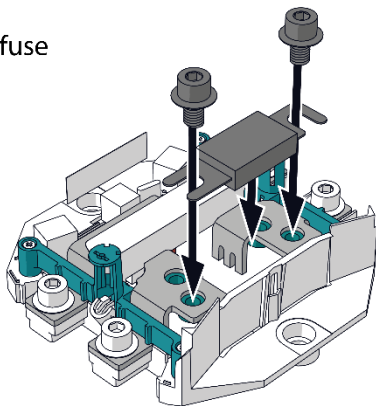

Step 7. Replace and lock the casing.

Step 8. Reconnect the battery pole.

Step 9. Store the removed busbar close to the MasterShunt 500 for future service purposes.

4.5 Parallel use (MasterBus only)

For load currents which exceed 300A continuous current, more than one MasterShunt 500 can be installed to monitor the same battery (bank). The MasterShunt 500s are then configured in parallel to the battery. The following figure shows the parallel configuration of two MasterShunt 500s (3) and (4) and other products.

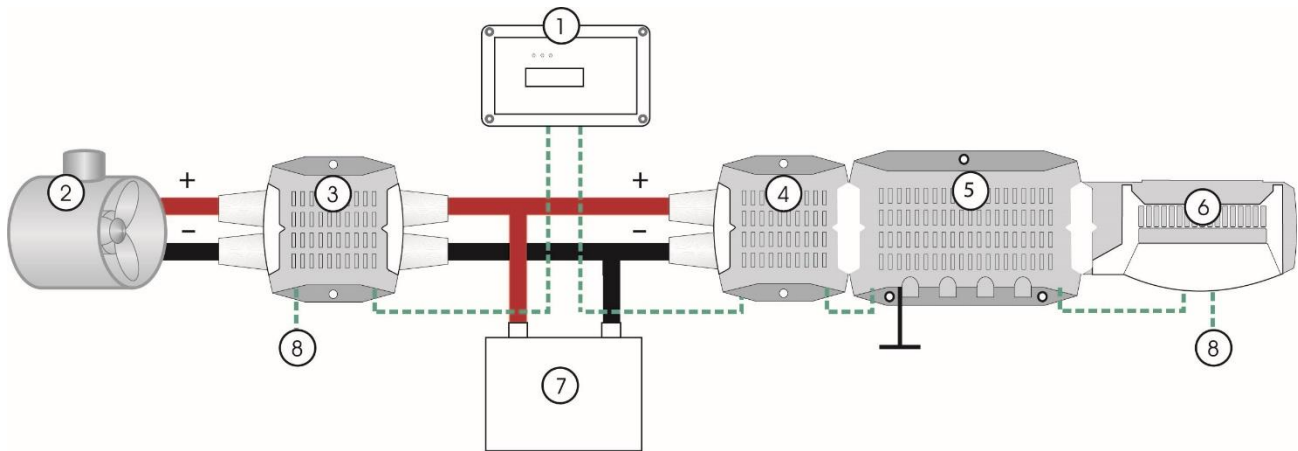

- | | |
|---|-------------------------------|
| 1. Remote panel | 5. DC Distribution 500 |
| 2. Bow thruster | 6. Digital DC 10x10A |
| 3. MasterShunt 500 in parallel 1, in Reversed setting | 7. Battery |
| 4. MasterShunt 500 in parallel 2 | 8. Network wiring (MasterBus) |

Figure 3 : Parallel system example

Note: When also using older versions of the MasterShunt 500 in parallel setup, make sure to select the new version (7702011x) as master and the older version as slave.

For parallel setup of two MasterShunt 500s, execute the following steps:

1. First reset any pre-used MasterShunt 500s to factory settings.
2. During First start up select Advanced mode/ Parallel mode on one of the MasterShunt 500s, this will become the Master.
3. Select the serial number(s) of the other MasterShunt 500(s), Refer to Figure 1. These MasterShunt 500(s) will be the slave(s).

After pressing the “Complete” button, the measurements of all paralleled MasterShunt 500s are combined and shown as one MasterShunt 500. The currents however are shown separately! This means, renaming the MasterShunt 500s can be convenient.

5 SETTINGS

The MasterShunt 500 can be monitored from a display like the Touch 10 (in a CZone network) or the EasyView 5 (in a MasterBus network). Some settings can only be adjusted from a laptop/notebook or PC connected to the MasterShunt 500 via a USB Interface.

5.1 About MasterBus

MasterBus is a CAN based, data network for communication between Mastervolt devices. The main connection to communicate with each MasterBus interface is MasterAdjust. MasterAdjust software is available as free to download software on the Mastervolt website: www.mastervolt.com. This tool runs on a Windows PC/notebook. Another option is to use a control panel such as the EasyView 5.

When the MasterShunt 500 is connected to MasterBus, open MasterAdjust. The MasterShunt 500 will be recognized by the MasterBus network automatically. The following sections use the screens as shown in MasterAdjust.

At first start up, MasterAdjust will guide you through the following settings:

Setting	Default	Range
① Select the language of MasterAdjust.	English	English, Nederlands, Deutsch, Français, Castellano, Italiano, Norsk, Svenska, Suomi, Dansk.
② Set the battery capacity to enable the MasterShunt 500 to calculate the state of charge.	Value from First Setup	30-10000Ah
③ Four different battery types can be selected. The spiral battery belongs to the AGM batteries.	Value from First setup	Flooded, Gel, AGM, MLI.
④ Nominal battery voltage, set at first set up.	Value from First setup	12V ,24V, 36V, 48V
⑤ Use this option for reversing input and output, when you installed the load at the left of the MasterShunt 500.	Off	Off, On
⑥ Use this option for parallel or single device configuration. "I + U only" monitors the current and voltage only.	Single device	Single device, I + U only, Parallel mode. See also chapter 4.5
⑦ Check your settings and confirm by pressing Finish setup . Modification of the settings afterwards requires a reset of the setup. See section 5.1.1.		

Figure 4: First start up

If you want to make changes afterwards, go to the Configuration tab, make the required changes and press **Reset setup**. See section 5.1.1.

5.1.1 Configuration

The following sections describe the settings as shown in MasterAdjust. With the CZone configuration tool, some of these settings are found under Advanced Settings or under Alarm/Switch Settings.

Variable	Meaning	Factory setting ¹⁾	Range	Notes
General				
Language	Change the language used in MasterAdjust.	English	English, Nederlands, Deutsch, Français, Castellano, Italiano, Norsk, Svenska, Suomi, Dansk.	MasterBus (MB) only
Name	Name of the battery bank..	MasterShunt 500	Any maximum 12 character name.	
Year	Set the MasterShunt 500 clock year.	2000	2000-2135	MB only

Variable	Meaning	Factory setting ¹⁾	Range	Notes
Month	Set the MasterShunt 500 clock month.	January	January-December	MB only
Day	Set the MasterShunt 500 clock day.	1	1-31	MB only
Hour	Set the MasterShunt 500 clock hour.	0	0-23	MB only
min	Set the MasterShunt 500 clock minute.	0	0-59	MB only
MasterBus power	In smart on mode this option will switch off MasterBus power when main current is in between 1.0A and -1.0A for more than 24 hours and the battery voltage has dropped below the float voltage. This prevents your battery from being discharged slowly by MasterBus power.	Always on	Off, Smart on, Always on.	MB only
Communication (requires installer rights)	Select MasterBus only (MB only), if the MasterShunt 500 is a slave unit in a cluster	MB & CZone	MB & CZone, MB only	
Battery				
Battery capacity	You see the battery capacity selected during FIRST START UP. Refer to Chapter 4.5. To change this value you need to reset the setup.	Value from First Setup	30-10000Ah	
Battery type	You see the battery type selected during FIRST START UP. Refer to Chapter 4.5. To change this value you need to reset the setup.	Value from First setup	Flooded, Gel, AGM, MLI	
Nominal voltage	Nominal battery voltage. To change this value you need to reset the setup.	Value from First setup	12V ²⁾	
Peukert	Peukert coefficient. Do not change this setting without extended knowledge of the installed batteries!	Flooded, Gel, AGM: 1.27 Li-ion: 1.00	1,00-2,50	CZone Advanced Settings
Amp=Full	Charge current for battery full related to battery capacity. Example: If the battery capacity is 200Ah, and this percentage is set to 2.0%, the battery is considered to be fully charged when the charge current has dropped below 200 x 2.0%, = 4A. Setting this value higher may be useful for old batteries which are beyond their economic life but have not been replaced yet	2.0%	0.1-10%	CZone Advanced Settings: Battery Full current [0-30A]
Float	This voltage must be set just below the lowest float voltage of all system charging devices at operating temperature. Float voltage is used to determine if the battery is fully charged (refer to section 3.1).	Flooded, Gel, AGM: 13.8V ²⁾ Li-ion: 13.5V ²⁾	12-15V ²⁾	CZone Advanced Settings
Absorption	This value is set to the recommended absorption voltage.	Flooded, Gel, AGM: 14.25V ²⁾ Li-ion: 14.25V ²⁾	12-15V ²⁾	CZone Advanced Settings
Reset setup <i>Reset setup will void warranty</i>	Reset the complete setup of the MasterShunt 500, this will reload all default factory settings. <i>This screen warns you for the possible consequences of your Mastervolt battery bank warranty by resetting the setup.</i>			MB only

Variable	Meaning	Factory setting 1)	Range	Notes
Alarm levels				
Voltage high	When the battery voltage rises above this level, the alarm function will be triggered.	Flooded, Gel, AGM: 15.0V ²⁾ Li-ion: 15.5V ²⁾	13-16 ²⁾	CZone Alarm/Switch Settings
High delay	The “alarm delay time” can be set to delay the alarm function when the DC-voltage rises above the <i>Voltage high</i> set point. As high voltage is accompanied by a high risk the factory setting for high delay is 0 seconds.	0 seconds	0-60 seconds	CZone Alarm/Switch Settings
Low voltage	Set the voltage value below which the alarm function <i>Battery pre low</i> will be triggered, Note: the <i>Battery pre low</i> level is higher than <i>Battery low</i> , to prevent the <i>Battery low</i> situation.	Flooded, Gel, AGM: 11V ²⁾ Li-ion: 11.5V ²⁾	8-15V ²⁾	CZone Alarm/Switch Settings
Very low voltage	The low voltage set point marks the voltage threshold of low battery. If the battery voltage drops below this value, the alarm function will be activated after the Low delay, see below.	Flooded, Gel, AGM: 10V ²⁾ Li-ion: 11V ²⁾	8-15V ²⁾	CZone Alarm/Switch Settings
Low delay	The “alarm delay time” can be set to delay the alarm function when the DC-voltage drops below the <i>Voltage low</i> set point. This delay prevents a false alarm as a result of a temporary voltage drop, after switching on heavy loads.	30 seconds	0-100 seconds	CZone Alarm/Switch Settings
Low alarm	Select this option to allow alarm pop-ups on a monitoring display	Off	On, off	CZone Alarm/Switch Settings
Battery Alarms				
Battery full	Set the State Of Charge value at which the alarm function <i>Battery full</i> will be triggered.	100%	30-100%	CZone Alarm/Switch Settings
Low battery	Set the State Of Charge value below which the alarm function <i>Battery pre low</i> will be triggered, Note: the <i>Battery pre low</i> level is higher than <i>Battery low</i> , to prevent the <i>Battery low</i> situation.	40% Li-ion: 30%	10-90%	CZone Alarm/Switch Settings
Very low battery	Set the State Of Charge value below which the alarm function <i>Battery low</i> will be triggered.	35% Li-ion: 20%	10-90%	CZone Alarm/Switch Settings
Temperature				
Unit	Set the unit in which the temperature is shown.	Celsius	Celsius or Fahrenheit	MB only
Level	Set the temperature level to trigger an event.	40°C	-20°C – 70°C	MB only
Timer 1&2				
Timer Select	Select the day at which timer 1 is activated.	Disabled	Disabled, Sun, Sat, Weekend, Daily, Monthly	MB only
Timer On	Set the hour at which timer 1 will start.	0	0...23	MB only
Timer On	Select the minute at which timer 1 will start.	0	0...59	MB only

Variable	Meaning	Factory setting ¹⁾	Range	Notes
Timer Off	Select the hour at which timer 1 will stop.	0	0...23	MB only
Timer Off	Select the minute at which timer 1 will stop.	0	0...59	MB only
Stop when full	Has for instance a generator stopped when the battery is full before timer 1 elapsed?			MB only

¹⁾ The factory settings for Li-ion batteries fit the Mastervolt Li-ion (MLI) batteries but do not necessarily fit other Li-ion batteries! Always follow the instructions provided by the battery manufacturer!

²⁾ These values are for a 12V system. For a 24V system, multiply by 2. For a 36V system, multiply by 3. For a 48V system, multiply by 4.

5.1.2 Events – System Automation

A device can be programmed to initiate an action at another connected device. This is very helpful in automation of your system but is not required for battery monitoring only.

In MasterBus this is done by means of event-based commands. In the Events tab you can program the MasterShunt 500 to act as an event source. Events which occur during the operation of the MasterShunt 500 will then trigger actions from other products.

Field	Meaning	Value
Event x source	Select an event that triggers an action, for example Battery pre low.	See <i>Event source</i> list
Event x target	Select the device that should take action, for example the generator	Selectable targets are system dependent
Event x command	Select the parameter that must be changed on the target device, for example Activate.	See command list of the selected device
Event x data	Data, for example On, is linked to the command.	Off, On, Copy, Copy Invert, Toggle

Table 1: MasterBus event parameters

The following table lists the event sources. The values are configurable, see section 5.1.1. There are no events with the MasterShunt 500 acting as an event target.

Event source	Description
Low voltage	The State Of Charge (SOC) drops below the Voltage pre low value
Very low voltage	The battery voltage drops below the Voltage low value
Voltage high	The battery voltage reaches the high voltage value
Low battery	The SOC drops below the Battery pre low value
Very low battery	The SOC drops below the Battery low value
Battery full	The SOC reaches the Battery full value
Battery >20%, > 40%, > 60%, > 80%, >100%	Battery SOC in % of capacity
Charging	The MasterShunt 500 measures charging current.
Timer 1, 2	Refer to section 5.1.1, <i>Timer settings</i>

Table 2: MasterShunt 500 MasterBus Event sources

5.1.3 Alarms

The MasterShunt 500 features six different alarm parameters which can be configured to custom chosen values. If the alarm conditions are met, i.e. the chosen value has been reached, the alarm function can trigger an action. For instance the alarm "Battery low" can trigger a generator to start and recharge the battery. The following table lists the available alarms.

Alarm	Description
Voltage high	When the battery voltage rises above the high voltage level (15V default value), the alarm function will be raised with the set High delay time.
Very low voltage	If the battery voltage drops below a preset value (10V default) this alarm is raised (after the set Low delay time).
Very low battery	This function will be triggered when the State Of Charge (SOC) drops below a preset value (35% default).
Fuse alarm	This alarm is raised when the internal MasterShunt 500 fuse is blown.
Low voltage	To prevent the battery from becoming discharged too deeply, a value above Voltage low can be set (11V default).
Low battery	To prevent the battery from draining, a SOC value above Battery low can be set (40% default).

Table 3: MasterShunt 500 alarm items

5.1.4 Monitoring

The MasterShunt 500 continuously monitors the battery's State of Charge (SOC). If the SOC drops below a pre-set value or the battery voltage is either too high or too low, the alarm function is activated. For alarm settings, automation and functions refer to sections 5.1.1, 5.1.2 and 5.1.3. The Monitoring menu is read-only.

Notes:

- At first start up and after a power reset, the MasterShunt 500 shows "State of Charge --- %". SOC will show a valid number when the battery bank is charged to full conditions.
- SOC and Remaining are not shown in the "I + U only"-mode.

Item	Description
State of Charge %	The actual amount of energy left in the battery, related to the selected battery capacity.
Remaining hh:mm:ss	The <i>time remaining</i> before the battery will be empty. Maximum value: 480 hrs (20 days). Under 24 hrs it shows hh:mm:ss, above that dd:hh. During charging it shows "--:--:--". This value depends on the current drawn.
Cap. Consumed	<i>Capacity consumed</i> shows how many Amp-hours (Ah) have been consumed from the battery bank.
Battery V	The measured voltage at the MasterShunt 500.
Battery A	The measured current through the poles of the MasterShunt 500. Charging appears as positive current, discharging as negative current.
Battery °C	The temperature measured by the temperature sensor, connected to MasterShunt 500. If a charger has been connected to the MasterShunt 500, this temperature sensor will be relevant for charge voltage correction!
Time	If you have set the [Time], this screen shows hh:mm:ss. Refer to section 5.1.1 for settings.
Date	If you have set the [Date], this screen shows dd:mm:yyyy. Refer to section 5.1.1 for settings.

5.1.5 History

To know the history of your battery bank can be very useful. It will help you to check if the battery capacity suits the application and when the battery needs to be replaced. The memory back up system of the MasterShunt 500 saves this data even if the battery was completely discharged or disconnected. The following parameters are only shown in MasterAdjust.

Message	Description															
Standard history																
Days running	The total number of days since the MasterShunt 500 was powered.															
Last time 100%	The number of days since the battery bank was charged up to 100% for the last time. To prevent damage the batteries must be charged to the full 100% regularly.															
Battery usage	The total number of charging cycles of the battery bank.															
Battery abuse	Slow and deep discharges below the battery's end voltage can reduce the expected lifetime of your batteries dramatically. This item shows the number of battery abuse cycles. A large number of abuse cycles might indicate small loads that stayed connected during a long period (for instance during wintertime). Get your electrical installation examined by a qualified installer if abuse cycles happen more than once!															
Discharged state	This timer will start when the SOC is below the "start under level" and will stop when the SOC is above the "stop above level" (with a DOD of 100%) <table border="1" data-bbox="391 801 919 1010"> <thead> <tr> <th></th> <th>Start under level</th> <th>Stop above level</th> </tr> </thead> <tbody> <tr> <td>Flooded</td> <td>50</td> <td>60</td> </tr> <tr> <td>Gel</td> <td>40</td> <td>50</td> </tr> <tr> <td>AGM</td> <td>50</td> <td>60</td> </tr> <tr> <td>MLI</td> <td>20</td> <td>30</td> </tr> </tbody> </table>		Start under level	Stop above level	Flooded	50	60	Gel	40	50	AGM	50	60	MLI	20	30
	Start under level	Stop above level														
Flooded	50	60														
Gel	40	50														
AGM	50	60														
MLI	20	30														
Discharged state	Counter that shows the number of times where the "start under level" has been reached.															
Calculated CEF	Charging Efficiency Factor (CEF) of the battery bank. This value is used for the calculation of the consumed Amp hours and the time remaining function. An efficiency of 70% indicates that the battery bank is at the end of its lifetime and needs to be replaced.															
Restarts																
Setup resets	The number of times the setup has been reset. Factory setting = 0. Resetting clears all history values except for this counter which is increased by one.															
Power cycles	Counts the number of times the MasterShunt 500 has been disconnected from the battery.															
Min/max history																
Deepest disch.	Shows the deepest discharge. The deepest discharge should never be higher than the rated capacity of the battery as specified by the battery manufacturer.															
Volt at low Ah	Shows the voltage at the moment of recording the deepest discharge.															
Highest voltage	Shows the highest voltage that was recorded. This voltage should never exceed the maximum charging voltage as specified by the battery manufacturer.															
Lowest voltage	Shows the lowest voltage that was recorded. This voltage should never exceed the minimum charging voltage as specified by the battery manufacturer.															
Alarm timers																
Voltage high	The timer shows the total amount of time the [Voltage high] on the alarm menu was raised.															
Very low voltage	The timer shows the total amount of time the [Voltage low] on the alarm menu was raised.															
Very low battery	The timer shows the total amount of time the [Battery low] on the alarm menu was raised.															
Warning timers																
Low voltage	The timer shows the total amount of time the [Voltage pre low] on the alarm menu was raised.															
Low battery	The timer shows the total amount of time the [Battery pre low] on the alarm menu was raised.															

5.2 About CZone

The CZone® network is an NMEA 2000-compliant CAN-based system. When the MasterShunt 500 is connected, open the CZone Configuration Tool on a Windows laptop or notebook. Either do the configuration while connected to the network or use a prepared configuration file (.zcf). Ensure that a DIP Switch is assigned. For detailed information on the configuration also see section 5.1.1.

Adding the MasterShunt 500 to a CZone system configuration

Precondition: This section assumes that a CZone system is already configured and the CZone Configuration Tool is open. In the CZone Configuration Tool, from the Modules tab, press the **Add** button. From the **Module Type** drop-down list select **Shunts** and continue with the following steps.

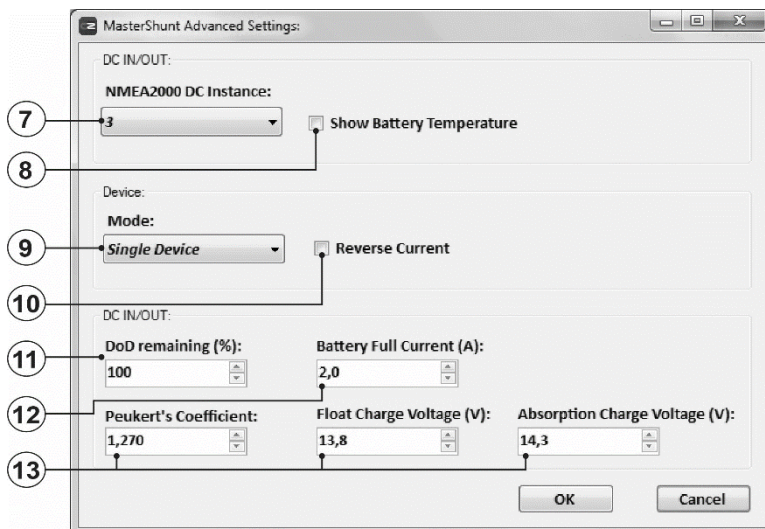
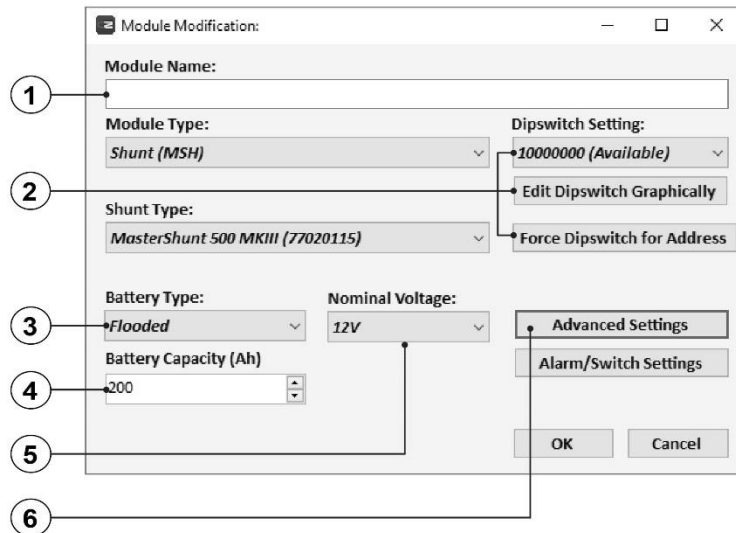

1. Enter an understandable **Module Name**.
2. Each device on a CZone network has a unique 'identification' number; the **Dipswitch**. This number is assigned during configuration and must match the DIP switch settings. On devices without physical DIP switches, like the MasterShunt 500, this is done in the CZone Configuration Tool. When connected to the system: either select one from the drop-down list, or edit graphically, and press the **Force Dipswitch for Address** button.
3. Select the **Battery Type**.
4. Enter the **Battery Capacity**.
5. Select the **Nominal Voltage**.
6. Option: press the **Advanced Settings** button to configure advanced options.
7. **NMEA2000 DC Instances** are used to differentiate between multiple DC sources in this case. Ensure all NMEA 2000 Instances are unique for each source being monitored.
8. Tick **Show Battery Temperature** to enable temperature monitoring.
9. Select the configuration **Mode** (more options in the near future).
10. Tick **Reverse Current** if the load is at the left side of the MasterShunt 500.
11. Enter the Depth of Discharge (**DoD**) value (100% = empty; 0% = full). An example: set the DoD remaining to 80% to discharge batteries only to 20%. This spare capacity of 20% will not appear in the monitoring. In this case the Battery Low level should be set to 0% and Battery Pre Low to 10% (see step 15).
12. Enter the **Battery Full Current** (also known as Amp=Full). This should be between 2.5% and 4% of Battery Capacity.
13. The default values of these settings fit most cases.
14. Press **OK** to return to the Module Modification window and press the **Alarm/Switch Settings** button.

Mastershunt Alarm/Switch Settings:

Module Name (MasterShunt)

DC IN/OUT

	On (V):	Alarm Severities:
High Voltage	15,0	Critical (Most Severe)
Low Voltage	11,0	Critical (Most Severe)
Pre Low Voltage	11,5	Standard

Battery:

	On (%):	Alarm Severities:
Battery Full	80	Important
Battery Pre Low	35	Standard
Battery Low	40	Important

	On (Days):	Alarm Severities:
Last Time100%	14	Critical (Most Severe)

Fuse

	Alarm Severities:
Blown Fuse	No Alarm

OK Cancel

15. Set the required **DC IN/OUT** and **Battery** alarm levels.

16. Select the required **Alarm Severities**.

17. Press **OK**.

Optionally configure digital switching by adding Circuit Controls in the Circuits tab (e.g. a battery low switch can be used to start a generator). Write the configuration to the network to use the new configuration.



For more information, please refer to the CZone® Configuration Tool Instruction manual.

6 MAINTENANCE



No specific maintenance to the MasterShunt 500 is required. Examine your electrical installation on a regular basis, at least once a year. Defects such as loose connections, burnt wiring etc. must be corrected immediately.

6.1 Replacement of batteries / reset history

When a new battery is installed, you need to set the correct parameters, like Nominal capacity, and clear the history:

- In MasterAdjust, press the "Reset setup" button and make the required changes.
- On the EasyView 5, execute the following procedure.

How to reset MasterShunt 500 with EasyView 5

1. On the EasyView 5, tap the EasyView 5 settings button  in the top right corner.
2. The display will show Configuration Disabled. Tap to enable and enter the pin code (can be found in EasyView 5 manual). The display will show Configuration Enabled.
3. Return to the favorites page and tap the EasyView system button  in the top right corner to list all devices.
4. Scroll to and tap the MasterShunt 500 that is connected to the new battery.
5. Tap the MasterShunt 500 settings button in the top right corner .
6. Scroll to "Reset setup" and tap OFF. The Mastervolt splash screen will be displayed and the EasyView 5 will return to the favorites page.

6.2 Replacement of a fuse

If a fuse is present, it is located inside the MasterShunt 500, see section 4.4. After replacement, switch on the consumers one at a time and monitor the current at each switch on. Refer to the manuals of these devices to check whether they are functioning correctly.



WARNINGS!

Changing the internal fuse of the MasterShunt 500 should be carried out by qualified personnel only!

Installation by unqualified personnel may result in major personal and material damage.

Only replace the blown fuse by a fuse of the same rating!

If a fuse has blown, a high current has flowed through several parts of the MasterShunt 500. As a result these parts and especially the fuse can be hot! Avoid burns!

7 Trouble shooting

Please contact your local Mastervolt Service Centre if you cannot correct a problem with the aid of the malfunction table below. See www.mastervolt.com for an extended list of Mastervolt service centers.

Failure	Possible cause	What to do
Display shows no MasterShunt 500	No terminating device placed at the ends of the MasterBus network	A MasterBus networks needs a terminating device on both ends of the network. Check if available (see Section 4.2).
	Network is configured as a ring network	Ring networks are not allowed. Check the connections of the network (see section 4.2).
	T-connections in the network	Check if T-connections are made in the network. T-connections are not allowed (see section 4.2).
	Error in the wiring	Check the cables and terminating devices (see section 4.2).
	Display not set up to show all devices	Check manual of the display.
	MasterShunt 500 is not configured in CZone configuration file	Open CZone Configuration Tool and check.
	MasterShunt 500 Dipswitch not correct	Open CZone Configuration Tool and check with Force Dipswitch for Address.
No voltage on load side of MasterShunt 500	Fuse blown	Investigate the cause of the blown fuse. Then replace the fuse (see section 6.2).
No accurate time remaining function	Wrong setting of the nominal battery capacity	Correct the battery capacity setting (see section 5.1.1, Battery).
State of Charge not accurate	Part of the load or the charger is connected at the battery side of the MasterShunt 500	Check whether all load and charger connections are at the load side of the MasterShunt 500 (see section 4.2).
	Wrong setting of the nominal battery capacity	Correct the battery capacity setting (see section 5.1.1, Battery).
	Self-discharge of the batteries which was not recorded by the MasterShunt 500	Recharge the batteries for at least 24 hours.
Battery is fully charged but SOC function does not show "100%"	Charging system has not met the conditions for a fully charged battery	See section 3.1 for an overview of the conditions for a fully charged battery.
State of Charge does not return to 100% after a long period of charging	Wrong setting of the float voltage	Lower the setting of the float voltage of the MasterShunt 500 by 0.1V (see section 5.1.1, Battery).
Wrong language is displayed	Wrong setting of the language at the MasterShunt 500	Adjust the language setting (see section 5.1.1, General).
	Wrong setting of the language at displaying device	Each separate connected device can have its own language setting. See the user manual of the connected remote control.
Alarm function is triggered by a short time voltage dip	Wrong setting of the parameters	Set the parameters correctly (see section 5.1.1, Alarm levels).
	Wrong setting of the alarm delay time.	Increase the delay time (see section 5.1.1, Alarm levels).
The communication LEDs blink alternately, indicating an alarm situation.	All failures can result in an alarm situation.	Look at your remote control to find out which failure needs to be corrected.

8 Specifications

8.1 Technical specifications

	MasterShunt 500 (MasterBus)	MasterShunt 500 (CZone)
Product code	77020110	77020115
Battery types	Gel, AGM, flooded, Lithium Ion	
Battery voltage	12, 24, 36* or 48* VDC	
Voltage Measurement	0-60 V (0.1V resolution)	
Voltage accuracy	± 0.6 % ± 1 digit	
Current Measurement	0-10A: <0.2A resolution, 10-100A: <0.5A resolution, 100-600A: <5A resolution	
Current accuracy	± 0.8 % of reading ± 1 digit	
Maximum current (With busbar or T-fuse 500A)	300A continuously 400A for 10 min. 500A for 5 min. 600A for 2 min.	
Parallel operation	Yes, for load currents which exceed 300A continuously	
Amp Hours Configuration	30-10000 Ah (5 Ah resolution)	
Time remaining	0-480 hours (1 min resolution)	
State of charge accuracy	± 1%	
Available languages	English, Nederlands, Deutsch, Francais, Castellano, Italiano, Norsk, Svenska, Suomi, Dansk.	See related display settings
Supply voltage	8-60 Vdc	
Main fuse	bus bar included in MasterShunt, ANL or Class T main fuse (450A or 500A) needs to be ordered separately	
Idle consumption	23 mA (normal operation), <1 mA (power saving, MasterBus off)	
MasterBus powering	Yes	Not applicable
System information	e.g. time remaining, voltage, current, state of charge	
Programmable alarms	warning low voltage, low state of charge, high voltage	
Options		
Remote panel	EasyView 5	Touch 10, Touch 5
General		
Dimensions, hwxwd	150 x 150 x 65 mm 5.9 x 5.9 x 2.6 inch	
Weight	0.7 kg 1.5 lb	
Protection degree	IP 21	

* 36 and 48 Vdc is supported from MasterShunt 500 device hardware version "K" onwards.

8.2 Dimensions

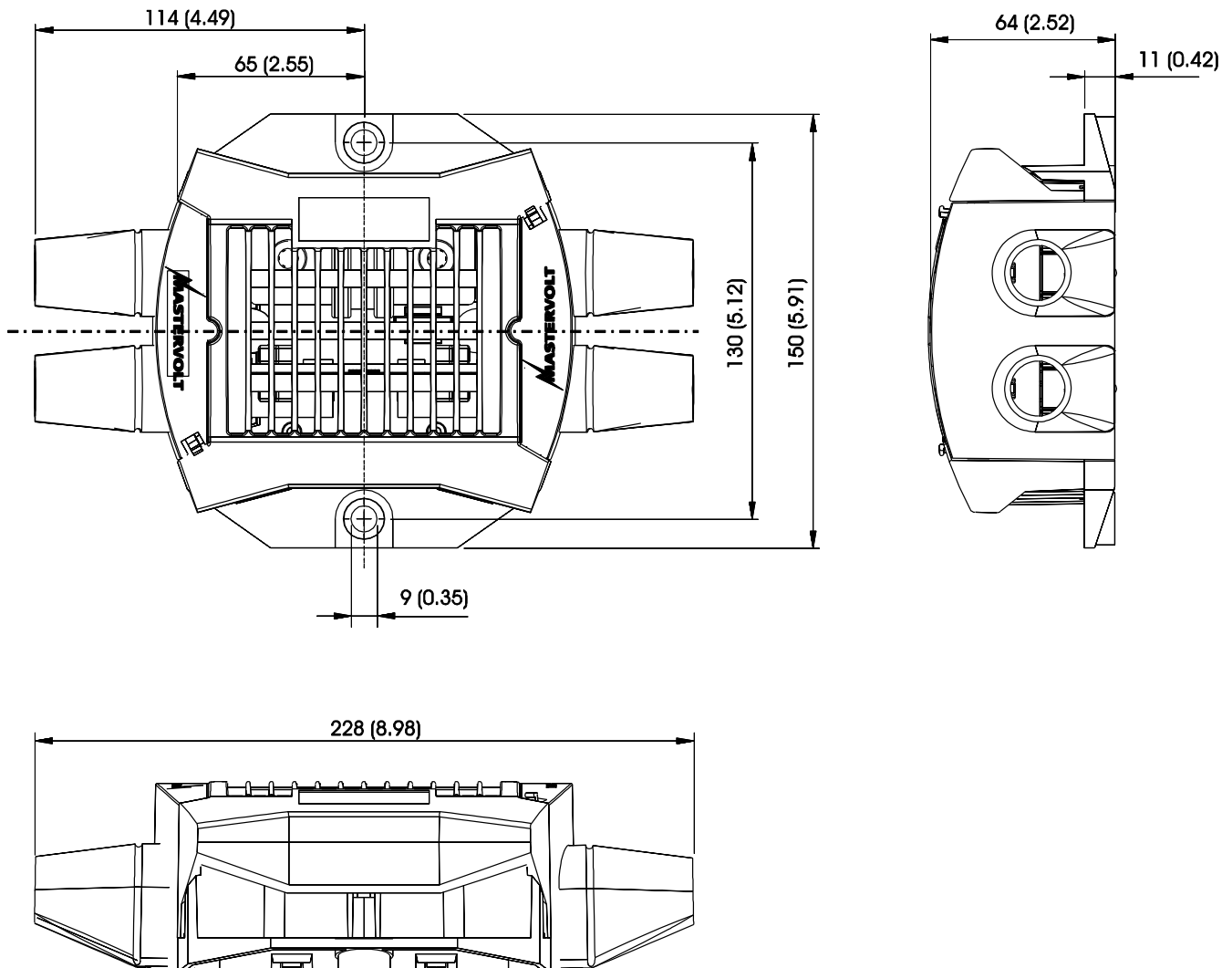

Figure 5: Dimensions MasterShunt 500 in mm [inches]

At the back of the MasterShunt 500 casing, the center-to-center distance (130mm, 5.12inch) of the mounting holes and DC fastening threads are displayed.



Europe, Middle East & Africa

Customer Service

T: +31 (0) 20 34 22 100

E: info.emea@OneASG.com

Technical Support

T: +31 (0) 20 34 22 100

E: ts.emea@OneASG.com

Location & Shipping

Advanced Systems Group
Snijdersbergweg 93
1105 AN Amsterdam
The Netherlands

Americas & Caribbean

Customer Service

T: +1 800 307 6702, Option 1

E: orderentry@marinco.com

Technical Support

T: +1 800 307 6702, Option 2

E: tsusa@mastervolt.com

Location & Shipping

Power Products, LLC
N85 W12545 Westbrook Crossing
Menomonee Falls, Wisconsin 53051
United States

Asia Pacific

Customer Service

T: +64 9 415 7261 Option 1

E: enquiries@bepmarine.com

Technical Support

T: +64 9 415 7261 Option 3

E: technical@bepmarine.com

Location & Shipping

BEP Marine
42 Apollo Drive
Rosedale, Auckland 0632
New Zealand