

Yacht Devices

User Manual

NMEA 2000 Battery Monitor YDBM-01
also covers models
YDBM-01N, YDBM-01R

Firmware version
1.00

2021

© 2021 Yacht Devices Ltd. Document YDBM-01-002. December 2, 2021. Web: <http://www.yachtd.com/>



NMEA 2000 Battery Monitor is certified by the National Marine Electronics Association.

NMEA 2000® is a registered trademark of the National Marine Electronics Association. SeaTalk NG is a registered trademark of Raymarine UK Limited. Garmin® is a registered trademark of Garmin Ltd.

Contents

Introduction	4
Warranty and Technical Support	5
I. Product Specifications	6
II. MicroSD Slot and Card Compatibility	8
III. Understanding the Basics	9
IV. Typical Use of the Device	12
V. Choosing a Shunt	18
VI. Installation and Connection of Device	20
VII. LED Signals	23
VIII. Quick Setup List	25
IX. Device Configuration and Settings	26
X. Battery Synchronization	48
XI. NMEA 2000 Digital Switching Support	53
XII. Firmware Updates	56
Appendix A. Troubleshooting	57
Appendix B. Supported NMEA 2000 Messages	60
Appendix C. Example of Configuration File	62

Package Contents

Device	1 pc.
This Manual	1 pc.
Stickers for MicroSD slot sealing	6 pc.
MicroSD card	Not supplied
NMEA 2000 Cable	Not supplied
External shunt	Not supplied

Introduction

This Manual contains information on how to install, configure and operate the Yacht Devices NMEA 2000 Battery Monitor YDBM-01 (hereinafter the Device). The Device is intended for use in NMEA 2000 marine electronics networks.

The Battery Monitor is primarily designed for monitoring a marine battery. However, you can use the Device with any single DC source (i.e. alternator, wind generator, etc.) or load (windlass, refrigerator, etc.). This capability increases both marine safety and sailing comfort by giving you full information about on-board DC sources and consumers.

To operate as intended, the Battery Monitor requires an appropriate external shunt, shunts in the range from 5A to 1200A are widely available. The Device should be properly wired and configured. At the minimum, you should specify drop voltage and maximum current for connected shunt. In addition, you can specify battery parameters such as nominal capacity and voltage, chemistry, etc.

Current and voltage measurement data, and, in case of batteries, calculated data (state of charge, consumed ampere-hours, battery time remaining) are output to an NMEA 2000 network. The data can be displayed on MFDs or instrument displays, and is available to all other devices within the NMEA 2000 network.

Current and voltage data measured by the Device, as well as battery case temperature data supplied by an external NMEA 2000 sensor, and calculated data like state of charge, can be used to manage channels of an NMEA 2000 digital switching system, and/or trigger a digital alarm unit compatible with standard NMEA 2000 PGNs 127501/127502. For example, you can configure the Battery Monitor to automatically raise a sound alert about low battery charge, or to turn some equipment on or off, or to start a genset to recharge the battery (see IX.3 and Section XI).

The Device incorporates a MicroSD card slot which allows using a standard FAT-formatted card to program the Device and update its firmware. For programming only, you may also use PC software with an appropriate NMEA 2000 gateway (from ActiSense, Maretron or Yacht Devices; see IX.2), or an MFD that supports installation description strings.

Thank you for purchasing the Battery Monitor, and Bon Voyage!

Warranty and Technical Support

1. The Device warranty is valid for two years from the date of purchase. If a Device was purchased in a retail store, the sales receipt may be requested when applying for a warranty claim.
2. The Device warranty is terminated in case of violation of the instructions in this Manual, case integrity breach, or repair or modification of the Device without the manufacturer's written permission.
3. If a warranty request is accepted, the defective Device must be sent to the manufacturer.
4. The warranty liabilities include repair and/or replacement of the goods and do not include the cost of equipment installation and configuration, or shipping of the defective Device to the manufacturer.
5. Responsibility of the manufacturer in case of any damage as a consequence of the Device's operation or installation is limited to the Device cost.
6. The manufacturer is not responsible for any errors and inaccuracies in guides and instructions of other companies.
7. The Device requires no maintenance. The Device's case is non-dismountable.
8. In the event of a failure, please refer to Appendix A before contacting technical support.
9. The manufacturer accepts applications under warranty and provides technical support only via e-mail or from authorized dealers.
10. The contact details of the manufacturer and a list of the authorized dealers are published on the website: <http://www.yachtd.com/>.

I. Product Specifications

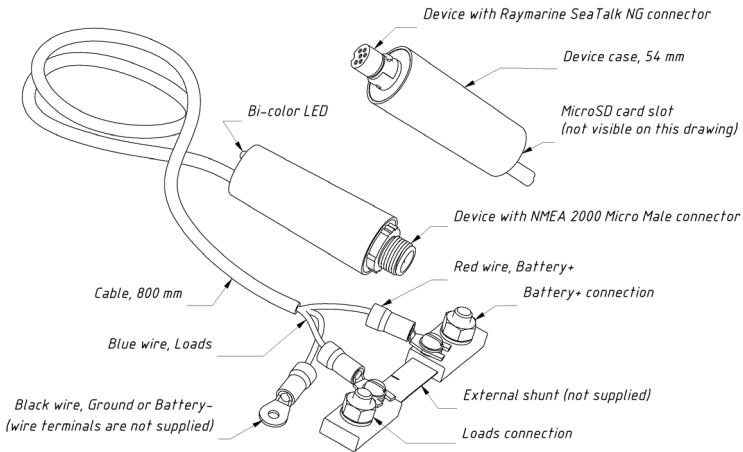

Figure 1. Drawings of YDBM-01N (left) and YDMB-01R (right)

Most of our Devices are supplied with different types of NMEA 2000 connectors. Models containing «R» in the suffix of the model name are equipped with NMEA 2000 connectors, and are compatible with Raymarine SeaTalk NG. Models containing N in the suffix are equipped with NMEA 2000 Micro Male connectors. You can connect the Device directly to a backbone, without a drop cable.

Device parameter	Value	Unit
Supply voltage (from NMEA 2000 interface)	7..16	V
Consumption current (NMEA 2000 interface), average	50	mA
Load Equivalency Number	2	LEN
External shunt rated current	5..2500	A
External shunt's nominal voltage drop (recommended)	75	mV
Shunt voltage measurement range	-50..50	mV
Current measurement accuracy (1)	±0.5	%
Voltage measurement accuracy	0.1	V
Maximum allowed DC voltage on inputs (with respect to GND input)	40	V
Breakdown voltage between NMEA 2000 network interface and inputs	2500	V _{RMS}
Device case length (without connector)	54	mm
Weight	60	g
Operating temperature range	-20..55	°C

Note 1: (1) not accounting for shunt accuracy which is typically ±0.25% or ±0.5%, and ±20 – 25 ppm/°C for temperature drift.



Yacht Devices Ltd declares that this product is compliant with the essential requirements of EMC directive 2004/108/EC.



Dispose of this product in accordance with the WEEE Directive. Do not dispose of electronic refuse with domestic or industrial waste.

II. microSD Slot and Card Compatibility

The Device has a slot for a microSD card that allows you to configure the Device (refer to Section IX) and update the firmware (refer to Section XII).

When you finish configuring the Device, we recommend sealing the card slot with the sticker that is supplied with the Device, or with a piece of tape to prevent water from entering the Device through the slot.



The Device slot has a springloaded «push-push» mechanism that ensures proper card fixation. Improper loading or unloading (withdrawing your finger too quickly, or not pushing until it clicks) may result in the unexpected ejection of the card from the slot. To avoid possible injury, damage or loss, please insert and eject the card with caution.

The Device supports microSD memory cards of all sizes and classes. The card must be formatted on a personal computer before it can be used in the Device. The Device supports the following file systems: FAT (FAT12, FAT16, MS-DOS), and FAT32. It does not support exFAT, NTFS, or any other file systems.

Be careful when inserting the microSD card into the Device. The card should be inserted with the label side toward the LED.

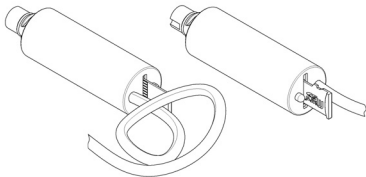

Figure 1. Device with a microSD card installed (pin side on the left, label side on the right)

III. Understanding the Basics

The primary use of the Device is to monitor battery voltage, current, temperature (via an external temperature sensor) and a number of calculated parameters, such as state of charge and consumed ampere-hours, via MFDs, instrument displays, PCs or mobile gadgets connected to an NMEA 2000 network.

The Device has three input wires which may be connected to a marine battery or other DC source (see Figure 1 in Section I) using an appropriate external shunt (purchased separately). The Device is capable of measuring both current and voltage. Both positive and negative amperage is measured. Negative values indicate battery discharge, positive indicate charging.

To report battery status and perform more accurate calculations, the Device requires battery temperature provided by an external NMEA 2000 thermometer, for example, Yacht Devices' Digital Thermometer YDTC-13.

Calculations of state of charge (SoC), consumed ampere-hours, time remaining and state of health (SoH) are based on Lead Acid or Lithium-ion batteries. Further information will primarily relate to these battery types. NiCad and NiMH batteries have significant memory and self-discharge effects, etc. which are not taken into account in calculations. Use of NiCad and NiMH batteries with the Device will decrease the accuracy of the calculations. Calculations can be turned off (see CALCS parameter or YD:CALCS command in Section IX), and the Device may be used to monitor battery voltage, current and temperature (with an external temperature sensor).

To obtain results for SoC, consumed ampere-hours, time remaining, SoH calculations usable, you have to specify the battery's characteristics, such as nominal voltage and capacity, in Device settings. If the capacity value is rated for a discharge rate other than 20 hours, you must specify the latter as the NOMINAL_RATE parameter value (see Section IX).

Since the Device is powered from the NMEA 2000 network, the Battery Monitor must be permanently connected to both the network and the monitored battery/DC source. This is a proven way to obtain credible values of state of charge, consumed ampere-hours and time remaining. Otherwise, you can rely only on voltage, current and temperature readings.

To power off your NMEA 2000 network without breaking the Device's connection to the battery, you may need a dedicated hardware solution, for instance, a Garmin NMEA 2000 Power Isolator (part number 010-11580-00). With such a device, you can place the Battery Monitor and other NMEA 2000 devices in different network segments, each of which can be powered off separately.

The Device is intended to measure battery voltage and current, continuously monitor battery charging and discharge, and calculate battery status data. An ideal battery always gives and takes 100% of its energy without any loss. In real-world conditions, the amount of energy available from a battery heavily depends on the discharge rate and, to a lesser extent, on the battery's temperature. The charging process, as well, is not 100% efficient.

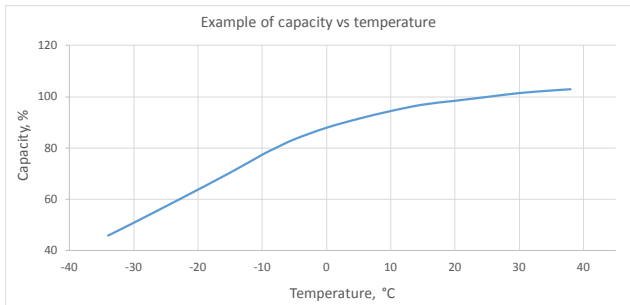

Figure 1. Typical capacity vs. temperature graph.

The Device accounts for charge efficiency and battery temperature (if working with an external temperature sensor), and the discharge rate (via the so-called Peukert's exponent, see Section IX). Consumed ampere-hours is compensated for charge efficiency only, and state of charge (SoC) is compensated for charge efficiency, temperature and Peukert efficiency.

Battery manufacturers normally specify maximum permitted depth of discharge values for their products. Depth of discharge (DoD) is the percentage of capacity removed from the fully charged battery. DoD is the inverse of state of charge ($\text{SoC} + \text{DoD} = 100\%$).

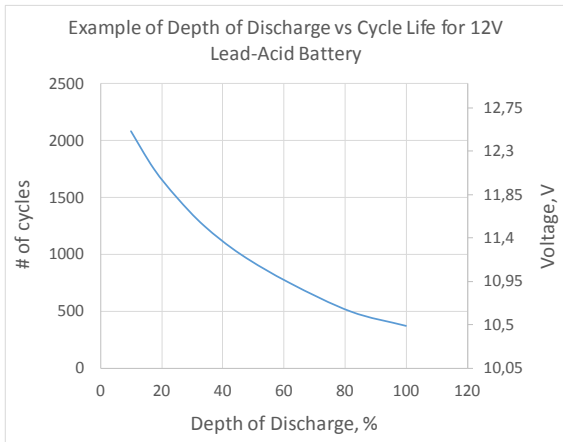

Figure 2. Typical cycle life (the number charge/discharge cycles before battery's performance has been significantly reduced) vs. Depth of Discharge

Discharging below the specified DoD limit would damage the battery and decrease its expected lifespan (commonly expressed as state of health — SoH). The purpose of monitoring battery's state of charge is to keep it from discharging deeper than permitted, and thus extend its operational life.

IV. Typical Use of the Device

The cases below do not comprise a comprehensive list of possible uses of the Device. They just give an overview of the Battery Monitor's capabilities in a number of real-life applications.

1. Monitoring of batteries on modern and legacy MFDs

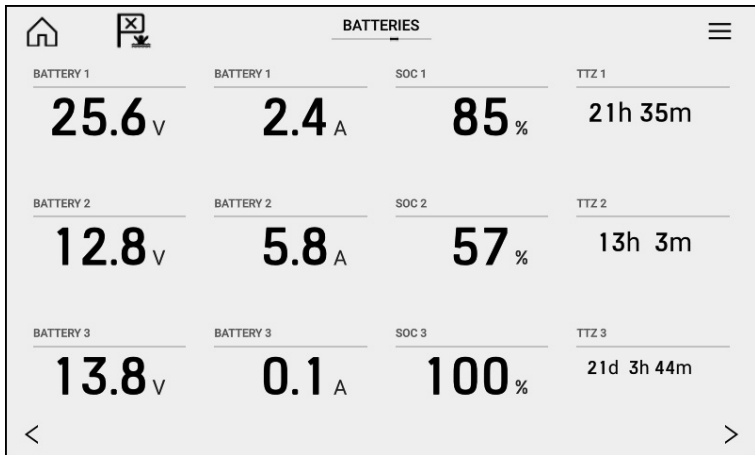

Figure 1. Battery state as displayed on a Raymarine Axiom MFD

For compatibility with legacy displays, the Device sends measurement data in PGN 127508 «Battery Status» (with voltage, current and case temperature data only) which is supported by most NMEA 2000 displays on the market. On the Figure 1 above, State of Charge (SoC) and Time Till Zero Charge (TTZ) from PGN 127506 «DC Detailed Status» are also shown.

2. Monitor solar panels and wind generators

Though the NMEA 2000 standard distinguishes between different types of power sources, the vast majority of modern MFDs are still incapable of monitoring solar panels and wind generators: they are shown as ordinary batteries. However, we believe that as these alternative power sources become more popular, MFD manufacturers will upgrade their solutions to let them handle the full range of data that the Battery Monitor supplies. In the Device's settings, you can configure DC source type as battery, solar cell, wind generator, alternator or DC converter (see Section IX).

3. Receive alerts on battery's State of Charge

If the battery SoC falls below the pre-specified threshold, it may decrease battery lifespan or even fail to perform a vital action, i.e. start an engine, feed navigation lights or run a bilge pump.

Using Digital Switching commands, the Device can be programmed to automatically detect an insufficiently state of charge, and turn on a specified DS channel in a specified bank (see IX.3 and Section XI for details).

```
YD:SS1 ON <40 0 0 1
```

In this example, the rule turns ON Channel #1 at the DS Bank #0 when the calculated SoC value momentarily drops below 40%.

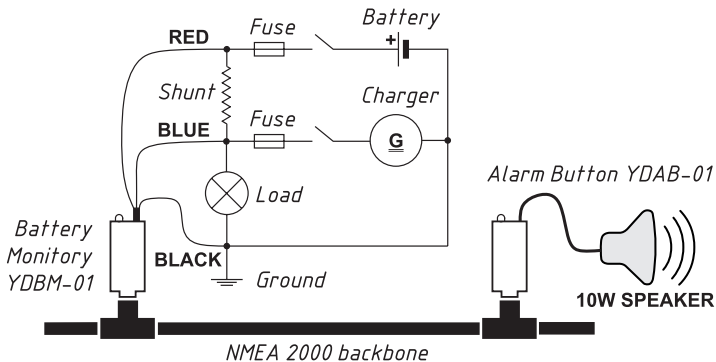

Figure 2. Basic digital switching system that provides alerts on battery's SoC

If the vessel has an NMEA 2000 Alarm Button (see XI.2) configured for bank #0 (see Figure 2), the rule will trigger an audio alert. The Alarm Button allows uploading of custom alarm signals or voice messages.

4. Turn on a genset to recharge the battery

On a sailing journey, there might be a lot of reasons to sail motorless. During such periods, an unexpected discharge of a starter battery may become a very unwelcome surprise. Even if you have top rated deep cycle batteries from a reputable brand, you need to keep an eye on their state of charge.

Let's configure a rule that is triggered if a battery voltage falls below the specified limit (in this case, 11.5 V) for longer than a specified period of time:

```
YD:SV1 ON <11.5 30 0 1
```

If you have an Alarm Button configured (see XI.2), you can receive an audible notification when the rule is triggered.

If your charging equipment is not capable to initiate recharging automatically, you may use the Device's Digital Switching commands to activate, e.g., a genset. In this case, you may require a dedicated genset start circuit. On the Figure 3, the Circuit Control (see XI.1) is used to close the contacts of the genset's starting circuit.

You may need an additional rule to release the starter when a genset is on (voltage is above 12 Volts for more than 5 seconds):

```
YD:SV1 OFF >12 5 0 1
```

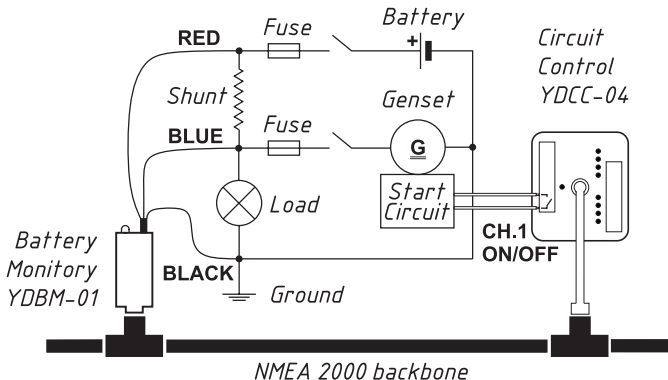

Figure 3. Simple digital switching solution to automatically start a genset on low battery voltage

5. Discover a specific behaviour of a DC load

In normal conditions, a bilge pump is rarely seen in operation. If it consumes current continuously, this may be a sign of hull leakage or other major problems. If the bilge pump feeding circuit is connected to a properly programmed Battery Monitor, you may apply the following rule:

```
YD:SC1 ON <-0.2 1200 0 1
```

The rule switches on DS channel #1 at bank #0 when the pump is continuously switched on (i.e. is consuming more than 0.2 amperes) for more than 20 minutes (1200 seconds). Negative current value means that the DC load is discharging the battery.

V. Choosing a Shunt

A shunt is a precision resistor, with a low resistance value, used for current measurement. Shunts in the range from 5A to 1200A are widely available. Another important parameter of the shunt, besides current, is the voltage drop at maximum load. Typical voltage drop value is 75 mV, but 50 mV and 100 mV shunts are also available.

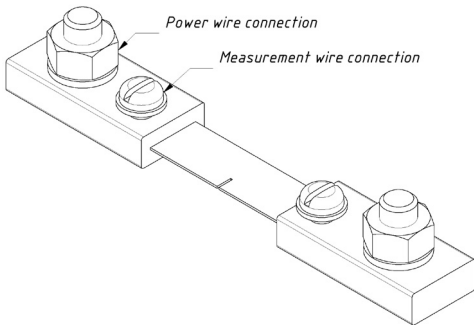

Figure 1. A typical shunt appearance

The Battery Monitor measures voltage drop across a shunt in the range of -50..50 mV. This means that, with the use of a shunt of a greater voltage drop than 50mV, the maximum measured current value will be less than the shunt's rated current. For 75 mV and 100mV shunts, the decrease will be, respectively, 65% and 50%. For instance, with a 75 mV / 10 A shunt, the maximum measured current will be approximately 6.5 A. In case of a 100 mV / 100 A shunt, the maximum measured current will be approximately 50 A. Please take this into account when choosing a shunt.

Moreover, due to safety concerns for continuous operation, it is recommended in IEEE standards to keep the maximum amperage in a connected circuit below two-thirds ($2/3$) of the shunt's rated current.

We recommend using a 75 mV shunt and selecting a current rating that takes into consideration that maximum current of your system should be less than 65% of the shunt's rated current. This provides for electrical safety, and accounts for the Device's 50 mV limitation. For example, if the maximum amperage in your system is 60 A, a 75 mV / 100 A rated shunt will be sufficient.

VI. Installation and Connection of Device

The Device requires no maintenance. The Device's case is not waterproof; please avoid installing the Device in a location where it can be flooded or sprayed by water, or get wet in rain. To minimize any possible water damage, we recommend that you cover the MicroSD card slot with a supplied sealing sticker when the slot is not used.

1. Connecting to monitored batteries / DC circuits

The Device is designed to work with a standard 75 mV shunt (not supplied) with no limits for rated current (shunts in the range from 5A to 1200A are widely available). If necessary, you may use a shunt with a nominal voltage drop of 50 or 100 mV, however, with some trade-offs (see Section V). You have to specify the shunt's rated current and nominal voltage drop in Device's settings, as well as battery's nominal voltage, capacity and discharge rate.

When making connections, refer to the diagram below (see Figure 1 on the next page).



To prevent the Device from being damaged, NEVER leave any of the Battery Monitor's red or blue wires unconnected. If you have not installed a shunt, and use the Device for measuring battery voltage, connect both wires to the positive terminal of the battery.

Make sure to use a marine grade power cable with proper voltage, current, temperature, and water/oil resistance ratings.

Proper choice of wire gauge is also important: the voltage drop in cables that connect the positive terminal of the battery to the shunt, and the ground wire of the Device to the negative terminal of the battery directly affects the measurement accuracy. Determine the amperage in your circuit noting the lengths of the cables. Assistance in choosing the optimal wire gauge for the lowest possible voltage drop may be found on the Web.

Please note that the Device readings will be non-zero when the Device is not connected to the shunt and the battery or when the Device is connected only to the shunt and not connected to the battery.

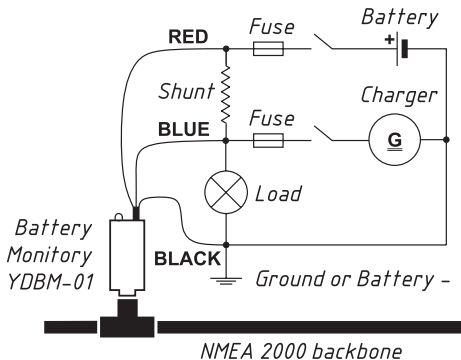

Figure 1. Device connections (Device's wires colours are in **BOLD**)

2. Connecting to NMEA 2000 Network

The Device can be directly connected to an NMEA 2000 network (no drop cable required). Before connecting the Device, turn off the bus power supply. If you have any questions regarding the use of connecting cables, terminators or connectors, please refer to the following documents:

- Technical Reference for Garmin NMEA 2000 Products (190-00891-00) for standard NMEA 2000 networks;
- SeaTalk NG Reference Manual (81300-1) for Raymarine networks.

After connecting the Device, close the lock on the connector to ensure reliability.

After you power on your NMEA 2000 network, the Device status LED gives a short green blink confirming successful initialization. Three further green flashes indicate successful connection to the NMEA 2000 network. See the full list of the Device's LEDs signals in Section VII.

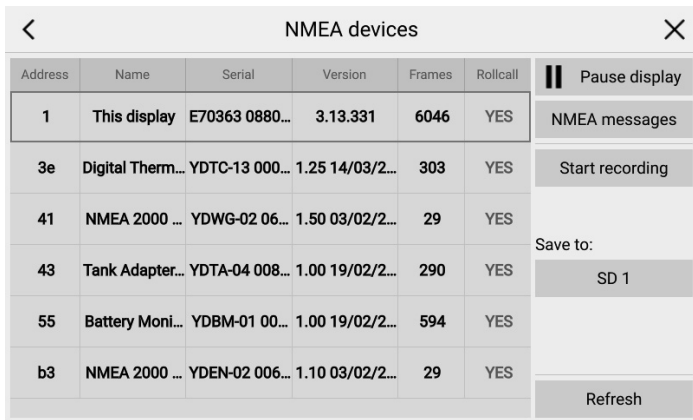

Address	Name	Serial	Version	Frames	Rollcall
1	This display	E70363 0880...	3.13.331	6046	YES
3e	Digital Therm...	YDTC-13 000...	1.25 14/03/2...	303	YES
41	NMEA 2000 ...	YDWG-02 06...	1.50 03/02/2...	29	YES
43	Tank Adapter...	YDTA-04 008...	1.00 19/02/2...	290	YES
55	Battery Moni...	YDBM-01 00...	1.00 19/02/2...	594	YES
b3	NMEA 2000 ...	YDEN-02 006...	1.10 03/02/2...	29	YES

Figure 2. NMEA devices list on a Raymarine Axiom MFD

Information about the Device will appear in the list of NMEA 2000 devices (SeaTalk NG, SimNet, Furuno CAN), or in the common list of external devices on your MFD (see the Figure 2 above). In most models, you can access this list via the «Diagnostics», «External Interfaces», or «External devices» menu.

VII. LED Signals

The Battery Monitor incorporates a bi-color Device status LED (see Figure 1 in Section I).

1. During startup and normal operation

After you power on the Device, the LED gives a single green flash that confirms successful initialization. A further series of 3 green flashes indicates the first reception of a CAN message from the NMEA 2000 network.

During normal operation, the Device's status LED blinks Green upon transmission of every third «Battery Status» message (PGN 127508). The default transmission interval for this message is set to 1.5 seconds; you can set your own value (refer to Section IX).

2. During MicroSD card operations

When you insert a MicroSD card into the slot, the LED gives a series of 3 signals which indicate the following:

- **GREEN, GREEN, GREEN** – the YDBM.TXT configuration file has been read, and changes have been applied to the current Device settings. The YDBMSAVE.TXT file with an updated configuration is saved on the card.
- **GREEN, RED, RED** – the YDBM.TXT configuration file has been read from the card, but the current configuration of the Device has not changed (either the configuration file does not differ from the current settings, or there are no settings in the configuration file). The YDBMSAVE.TXT file with an actual configuration is saved on the card.
- **RED, RED, RED** – no configuration file found on the card, or the file system is unsupported.

You can safely remove the MicroSD card when the flash sequence is finished.

3. During synchronization

When the Full Synchronization (see Section X) is in progress, and for one hour after the process has been completed, the Device emits sequences of 6 flashes every 20 seconds (see Figure 1 in X.2).

When the Partial Synchronization is finished (see X.1), the LED gives a series of four GREEN signals.

4. During firmware updates

The LEDs' behaviour during firmware updates is described in the Section XII.

VIII. Quick Setup List

The table below contains the minimal number of settings (described in the next Section) that must be specified to allow the Battery Monitor to work with your system. To have a quick reference at hand, you may fill in the «Value» column based on your battery and shunt manufacturers' documentation.

Section	Parameter	Value	Notes
NMEA 2000	BATTERY: Instance (unique battery number)		0 for the first or a single battery, 1 for the next battery and so on
Battery parameters	NOMINAL_VOL: Nominal voltage, Volts		Max. 36 V
	CAPACITY: Nominal capacity, ampere-hours		
	NOMINAL_RATE: Nominal discharge rate, hours		Most common: 20 h (default)
	CHEMISTRY: Battery chemistry		LEAD_ACID (default), LI_ION; NICAD, NIMH (1)
State of Charge (SOC) and Health	CALCS: Turns on/off calculations of SoC and SoH values		Default: OFF
External shunt	SHUNT_VOL: Voltage drop, millivolts		0.75 mV recommended
	SHUNT_CUR: Rated current, amperes		5..2500 A

Note: (1) see Section III for details.

IX. Device Configuration and Settings

The Device can be configured using two different methods:

1. With the configuration file YDBM.TXT on a MicroSD card. You will need laptop or smartphone with a text editor and a MicroSD card slot.
2. With a dedicated set of commands which can be entered into the Device's installation description field via specialized PC software, such as Yacht Devices' CAN Log Viewer, ActiSense NMEA Reader, or Maretron N2KANalyzer. Installation description strings are also supported by some MFD models.

In the previous section «Quick Setup List», you can find the minimal settings that must be specified in order for the Battery Monitor to work with your system and record values for reference.

1. Device Configuration with a MicroSD card

To configure the Device, a configuration text file YDBM.TXT should be created in the root folder of the MicroSD card. A sample configuration file is included in Appendix C. File contents should match the following rules:

- parameters and their values have to be entered in UPPER CASE;
- each parameter must reside on a separate line;
- commentary lines must start with the # symbol which makes them non-executable.

Insert a FAT or FAT32 formatted Micro SD card, containing an YDBM.TXT configuration file in its root folder, into the Device. After few seconds, the status LED gives a series of 3 signals (see Section VII) indicating that the configuration file has (or has not) been processed. If the configuration file is located and accepted, a newly created YDBMSAVE.TXT file with the current configuration of the Device appears in the card's root folder.

After the series of 3 LED signals, you can remove the card and check the YDBMSAVE.TXT file to make sure that the configuration file has been properly interpreted. You can also load an empty YDBM.TXT file (zero length, or comments-only) into the Device to get a YDBMSAVE.TXT file with the full configuration

of the Device, and then use it as a template for further configuration.

Table 1 below lists the full set of configuration parameters to be included in the configuration file. Vertical lines in the list of arguments mean that only one of the values should be specified. Square brackets are used to group the arguments.

Table 1. Configuration file parameters

Section	Parameter	Notes
CFGRESET	(no arguments)	Resets all Device settings to their default values. If this string is present in the configuration file, all other settings are ignored. IMPORTANT! When you use this parameter, all calculation results for SoC, consumed ampere-hours, time remaining, SoH are automatically reset (1).
RESET_RULES	(no arguments)	Resets all digital switching rules to their default state, i.e. NEVER
SHUNT_CUR=x	x – integer from 1 to 2500. Factory setting: 50	External shunt rated current in amperes. Specify this value according to your actual shunt's nominal settings.
SHUNT_VOL=x	x – integer from 50 to 100. Factory setting: 75	External shunt voltage drop in millivolts. Specify this value according to your actual shunt's nominal settings.

Table 1 continued

Section	Parameter	Notes
TEMPERATURE =x UNKNOWN	x – integer from 0 to 252. Factory setting: UNKNOWN	NMEA 2000 temperature instance (don't confuse with NMEA 2000 device instance or data type) for the battery temperature measuring device. If no such device is present, set to UNKNOWN.
BATTERY=x	x – integer from 0 to 252. Factory setting: 0	NMEA 2000 battery instance of the Device. 0 for the first or single battery, 1 is for the next and so on.
DC_TYPE=BATTERY ALTERNATOR CONVERTOR SOLAR_CELL WIND_GENERATOR	Factory setting: BATTERY	DC Type for PGN 127506 «DC Detailed Status». Legacy NMEA 2000 devices may not support this PGN.
CAPACITY=x	x – integer from 1 to 65532. Factory setting: 100	Battery capacity in ampere hours in PGN 127513 «Battery Configuration Status». IMPORTANT! When you change this parameter, all calculation results for SoC, consumed ampere-hours, time remaining and SoH are automatically reset (1).
NOMINAL_RATE=x	x – integer from 1 to 100. Factory setting: 20	Battery discharge rate (in hours) at which the manufacturer rates the battery capacity.

Table 1 continued

Section	Parameter	Notes
CHARGED_VOL=x UNKNOWN	x – from 1.0 to 40.0, one decimal place. Factory setting: 13.2	One of the 3 charged criteria: voltage (in volts) which is sufficient to consider the battery as fully charged when the battery voltage remains above this value. This parameter should always be slightly (0.3..0.5V) lower than the cut-off (the end of charge) voltage of the charger. UNKNOWN sets voltage to the default value for Lead Acid and Lithium Ion battery types, see Table 1 in X.3. Use UNKNOWN for NiCD, NiMH batteries.
CHARGED_CUR=x	x – from 0.5 to 10.0, one decimal place. Factory setting: 4.0	One of the 3 charged criteria: if the charge current drops below this value (expresses as a percentage of the nominal capacity), the battery is considered as fully charged.
CHARGED_PERIOD=x	x – integer from 1 to 50. Factory setting: 3	One of the 3 charged criteria: time period (in minutes) during which voltage and current conditions set in CHARGED_VOL and CHARGED_CUR parameters should be met to consider the battery as fully charged.
BATTERY_TYPE =FLOODED GEL AGM UNKNONN	Factory setting: FLOODED	Battery type in PGN 127513 «Battery Configuration Status» (for reporting only).

Table 1 continued

Section	Parameter	Notes
EQUALIZ_ SUPPORT=NO YES UNKNOWN	Factory setting: UNKNOWN	«Supports Equalization» parameter in PGN 127513 «Battery Configuration Status» (used for reporting only, not for calculations).
NOMINAL_VOL=6 12 24 32 36	Factory setting: 12	Nominal voltage in PGN 127513 «Battery Configuration Status». Changing this parameter will set the charged voltage to default value. Place this parameter before CHARGED_VOL in configuration file.
CHEMISTRY=LEAD_ACID LI_ION NICAD ZNO NIMH	Factory setting: LEAD_ACID	«Battery Chemistry» parameter in PGN 127513 «Battery Configuration Status». Used for reporting, to choose default values of settings and for calculations.
TEMP_COEF=x	x – from 0.0 to 5.0, one decimal place. Factory setting: 0	Battery temperature coefficient (capacity percent per centigrade degree) in PGN 127513 «Battery Configuration Status». Sets the temperature dependency of battery capacity and is used for calculations when temperature sensor is available. Typical values: 1.0% for Lead Acid batteries, 0.5% for Lithium Ion batteries.

Table 1 continued

Section	Parameter	Notes
PEUKERT =x	x – from 1.00 to 1.50, two decimal places. Factory setting: 1.25	Peukert's Exponent (2) field in PGN 127513 «Battery Configuration Status». The Peukert's exponent represents the effect of discharge rate on battery capacity. If the value is not known, keep it at 1.25 for lead acid batteries, and change to 1.05 for Li-ion batteries. For other types of batteries, if the exponent value is not specified, set it to 1.00 which disables the Peukert compensation.
CHARGE_EFF=x	x – integer from 50 to 100. Factory setting: 95	Charge Efficiency Factor (in percent) in PGN 127513 «Battery Configuration Status»: the ratio between the amount of energy removed from a battery during discharge and the amount of energy used to restore the original capacity during charging. The value 100 disables the charge efficiency compensation. Charge Efficiency of Li-ion batteries higher than Lead Acid batteries: recommended value is 99%.

Table 1 continued

Section	Parameter	Notes
CALCS=OFF ON	Factory setting: OFF	Enables or disables calculation of the battery status information (SoC, consumed ampere-hours, time remaining, SoH). When this parameter is set to OFF, only battery instance and DC Type data are included into NMEA 2000 PGN 127506 «DC Detailed Status». IMPORTANT: when you set CALCS to ON, all calculation results for SoC, consumed ampere-hours, time remaining, SoH are automatically reset (1).
FULL_SYNC=OFF ON		Run/stop Full Synchronization with the battery (see Section X).
MARETRON=OFF ON	Factory setting: OFF	Compatibility mode of digital switching functions for Maretron and Carling Tech equipment (3).
SXn_a=[c t b ch] NEVER		Digital Switching rules (see IX.3 for details)

Note (1): It means that SoC and SoH values will be 100%, consumed Ah will be 0Ah. If you connect a new fully charged battery after a settings reset, no synchronization is needed. Otherwise, if you connect a battery of less than one year old, and/or partially charged, or you do not need to monitor SoH, a Partial Synchronization is required. For older batteries and/or credible SoH readings, you should perform a Full Synchronization (refer to X.1 and X.2 for details).

Note (2): The Peukert equation approximates the effect of discharge rate on battery capacity. The Device takes the Peukert effect into account for the state of charge calculation. An ideal (theoretical) battery has a value of 1.0. For lead-acid batteries, the value of the Peukert constant is in the range of 1.10–1.25. If the manufacturer has not specified the Peukert's exponent for the battery, you may inquire about it. If the battery documentation contains values of the battery capacity for at least two different discharge hour rates, you may calculate the exponent on your own using the following formula:

$$k = \frac{\log(t_2) - \log(t_1)}{\log\left(\frac{C_1}{t_1}\right) - \log\left(\frac{C_2}{t_2}\right)}$$

where:

k – Peukert's exponent;

t1 and t2 – the discharge hour rates #1 and #2;

C1 and C2 – battery capacity values for discharge hour rates #1 and #2.

Please note that Peukert's formula is no more than a rough approximation of reality, and that at very high currents, battery capacity will be even lower than predicted from a fixed exponent.

Note (3): When the Maretron compatibility mode is ON, the Device sends the command message PGN 126208 «Group Function» (for compatibility with Maretron and Carling Tech equipment) after every PGN 127502 «Switch Bank Control» sent.

2. Device configuration with Installation Description strings

Installation description strings are stored in the Device's memory. In practice, installers use them to specify device location, or leave text notes or contact information. To set an installation description string, you may use PC software and a hardware gateway to an NMEA 2000 network. Some MFDs also allow editing of installation description strings. Please refer to your software or chart plotter documentation for details.

Device Properties

Address Claim

Address: 85 | HEX: 55 | Update

Unique number: 780001

Manufacturer code: 717

Device instance: 1

System instance: 0

Class / function: 35 / 170

Industry: 4: Marine

Self-configurable: Yes | Update

Product Information

Database version: 2.100

Product code: 7721

Model version: Battery Monitor / YACHTD.COM

Model ID: YDBM-01

Software version: 1.00 19/02/2021

Serial: 00780001

Certification: Not applicable

LEN (mA): 2 [100 mA]

Heartbeat

CAN1 CAN2 Equipment

Updated: 00:23:26.326

Configuration Information

Installation description 1: [Empty]

Installation description 2: YD:DEV 1 DONE

Manufacturer information: Yacht Devices Ltd., www.yachtd.com | Update

Refresh

Figure 1. Programming with CAN Log Viewer

To program the Battery Monitor, open the device properties window and enter a command string starting with YD: characters into the installation description field #2. For example, YD:DEV 1 will change the NMEA 2000 device instance of the Device to 1. If the command is accepted by the Device, it adds DONE to the entered string, and YD:DEV 1 DONE message is displayed in the installation description field. If a command is entered without the last argument, the device returns the current value of the argument.

Figure 1 illustrates the Device programming with free CAN Log Viewer software. To open the window shown, select «NMEA 2000 Devices» from the View menu, refresh the list of devices, select the Battery Monitor, and click the «Properties» button. The multi-platform application (Microsoft Windows, Mac OS X and Linux) is downloadable from <http://www.yachtd.com/downloads/>.

To connect your PC to the NMEA 2000 network, you may use any appropriate gateway. We recommend the following Yacht Devices products: NMEA 2000 Wi-Fi Gateway YDWG-02, NMEA 2000 USB Gateway YDNU-02, and NMEA 2000 Ethernet Gateway YDEN-02.

Please note that the NMEA 2000 device instance can be edited by entering a new value into the dedicated field (see «Address Claim» pane on the screenshot).

After you enter the command, as shown in Figure 1 (click the «Update» button to apply changes), the value in the «Device Instance» field will be changed to 1, and «Installation Details 2» field will be changed to YD:DEV 1 DONE.

The full set of commands is listed in Table 1 below. For all commands and arguments, use UPPER CASE letters. Parameters in square brackets [] described below can be omitted to obtain the current setting's value.

Table 1. Installation description strings

Syntax	Examples	Description
YD:RESET	–	Resets all Device settings to their default values. IMPORTANT! When applied, this command automatically resets all calculation results for SoC, consumed ampere-hours, time remaining, SoH (see IX.1, Note 1 to Table 1).
YD:RESET_RULES	–	Resets all digital switching rules to NEVER, see IX.3.

Table 1 continued

Syntax	Examples	Description
YD:SHUNT_CUR [1..2500]	YD:SHUNT_CUR 10	Set external shunt rated current in amperes (1..2500 A, integer value). Specify this value according to your actual shunt's nominal settings. Factory setting: 50
YD:SHUNT_VOL [50..100]	SHUNT_VOL 75	External shunt voltage drop in millivolts (50..100 mV, integer value). Specify this value according to your actual shunt's nominal settings. Factory setting: 75
YD:TEMPERATURE [0..252 UNKNOWN]	YD:TEMPERATURE 1	Sets NMEA 2000 temperature instance for the battery temperature measuring device (0..252, integer value), don't confuse with NMEA 2000 device instance or data type. If no such device is present, use UNKNOWN. Factory setting: UNKNOWN
YD:BATTERY [0..252]	YD:BATTERY 2	Sets NMEA 2000 battery instance of the Device (0..252, integer value), 0 for the first or single battery. Factory setting: 0

Table 1 continued

Syntax	Examples	Description
YD:DC_TYPE [BATTERY ALTERNATOR CONVERTOR SOLAR_CELL WIND_GENERATOR]	YD:DC_TYPE SOLAR_ CELL	Specifies DC Type in PGN 127506 «DC Detailed Status». Legacy NMEA 2000 devices may ignore this PGN. Factory setting: BATTERY
YD:CAPACITY [1..65532]	YD:CAPACITY 120	Specifies battery capacity (in ampere hours) in PGN 127513 «Battery Configuration Status» (1..65532 Ah, integer value). IMPORTANT! Changing this value resets all calculation results for SoC, consumed ampere-hours, time remaining, SoH (see X.1, Note 1 to Table 1). Factory setting: 100
YD:NOMINAL_RATE [1..20]	YD:NOMINAL_RATE 10	Sets the battery discharge rate (in hours) at which the manufacturer specifies the capacity (1..100, integer value). Factory setting: 20

Table 1 continued

Syntax	Examples	Description
YD:CHARGED_VOL [1..40 UNKNOWN]	YD:CHARGED_VOL 13.8	<p>One of the 3 charged criteria: sets voltage (in volts) which is sufficient to consider the battery as fully charged when the battery voltage remains above this value (1..40 V, in 0.1 V steps). The value should always be set slightly (0.3..0.5V) lower than the cut-off (the end of charge) voltage of the charger.</p> <p>Factory setting: 13.2</p> <p>UNKNOWN sets voltage to the default value for Lead Acid and Lithium Ion types), see Table 1 in X.3. Use UNKNOWN for NiCD, NiMH batteries.</p>
YD:CHARGED_CUR [0.5..10.0]	YD:CHARGED_CUR 4.8	<p>One of the 3 charged criteria: sets the end-of-charge condition: if the charge current drops below this value (expresses as a percentage of the nominal capacity), the battery is considered as fully charged (0.5..10%, in 0.1% steps)</p> <p>Factory setting: 4</p>

Table 1 continued

Syntax	Examples	Description
YD:CHARGED_PERIOD [0..50]	YD:CHARGED_PERIOD 5	One of the 3 charged criteria: sets the time period (in minutes) during which voltage and current conditions set in YD:CHARGED_VOL and YD:CHARGED_CUR commands should be met to consider the battery as charged (1..50 min, integer value). Factory setting: 3
YD:BATTERY_TYPE [FLOODED GEL AGM UNKNOWN]	YD:BATTERY_TYPE GEL	Specifies battery type in PGN 127513 «Battery Configuration Status» (for reporting only). Factory setting: FLOODED
YD:EQUALIZ_SUPPORT [NO YES UNKNOWN]	YD:EQUALIZ_SUPPORT NO	Specifies «Supports Equalization» parameter in PGN 127513 «Battery Configuration Status» (for reporting only). Factory setting: UNKNOWN
YD:NOMINAL_VOL [6 12 24 32 36]	YD:NOMINAL_VOL 24	Specifies nominal voltage in PGN 127513 «Battery Configuration Status». Changing this parameter will set the Charged Voltage to default value. Factory setting: 12.

Table 1 continued

Syntax	Examples	Description
YD:CHEMISTRY [LEAD_ACID LI_ION NICAD ZNO NIMH]	YD:CHEMISTRY LI_ION	Specifies «Battery Chemistry» parameter in PGN 127513 «Battery Configuration Status». Used for reporting, to choose the default values of settings and for calculations. Factory setting: LEAD_ACID
YD:TEMP_COEF [0..5]	YD:TEMP_COEF 2.3	Specifies battery temperature coefficient (capacity percent per centigrade degree) in PGN 127513 «Battery Configuration Status» (0..5 %/°C, in 0.1 steps). Factory setting: 0 The coefficient accounts for the temperature dependency of battery capacity (when temperature sensor is available). Typical values are: 1.0% for Lead Acid batteries, 0.5% for Lithium Ion batteries.

Table 1 continued

Syntax	Examples	Description
YD:PEUKERT [1.00..1.50]	YD:PEUKERT 1.45	<p>Specifies Peukert's exponent in PGN 127513 «Battery Configuration Status» (1.00..1.50, in 0.01 steps). The Peukert's exponent represents the effect of discharge rate on battery capacity.</p> <p>Factory setting: 1.25.</p> <p>If the value is not known, keep it at 1.25 for lead acid batteries, and change to 1.05 for Li-ion batteries. For other types of batteries, if the exponent value is not specified, set it to 1.00 which disables the Peukert compensation (see IX.1, Note 2 to Table 1).</p>

Syntax	Examples	Description
YD:CHARGE_EFF [50..100]	YD:CHARGE_EFF 90	<p>Specifies Charge Efficiency Factor (in percent) in PGN 127513 «Battery Configuration Status the ratio between the amount of energy removed from a battery during discharge and the amount of energy used to restore the original capacity during charging (50..100%, integer value). The value 100 disables the charge efficiency compensation.</p> <p>Charge Efficiency of Li-ion batteries higher than Lead Acid batteries: recommended value is 99%.</p> <p>Factory setting: 95.</p>
YD:CALCS [ON OFF]	YD:CALCS ON	<p>Enables or disables calculations of the battery status information (SoC, consumed ampere-hours, time remaining, SoH). When set to OFF, only battery instance and DC Type data is included into NMEA 2000 PGN 127506 «DC Detailed Status».</p> <p>Factory setting: OFF</p> <p>IMPORTANT: When applied, this command automatically resets all calculation results for SoC, consumed ampere-hours and time remaining, SoH (see IX.1, Note 1 to Table 1).</p>

Table 1 continued

Syntax	Examples	Description
YD:FULL_SYNC [ON OFF]	YD:FULL_SYNC ON	Run/stop Full Synchronization with the battery (see Section X). Without parameters, the command displays the current value (ON or OFF), and the current state of synchronization process, if Full Synchronization is in progress.
YD:SOC	YD:SOC	Returns current State of Charge value and the date of last Partial Synchronization.
YD:SOH	YD:SOH	Returns current State of Health value and the date of last Full Synchronization. If Full Synchronization is on (see «YD:FULL_SYNC» above or section IX.1, «FULL_SYNC» in Table 1) this also returns the current state of Full Synchronization process.
YD:CONSUMED_AH	YD:CONSUMED_AH	Returns number of consumed Ah value.
YD:MARETRON [ON OFF]	YD:MARETRON ON	Sets compatibility mode for Maretron and Carling Tech digital switching equipment (see IX.1, Note 3 to Table 1). Factory setting: OFF

Table 1 continued

Syntax	Examples	Description
YD:DEV [0..255]	YD:DEV 0	Sets NMEA 2000 device instance (0..255, integer value). Factory setting: 0
YD:SYS [0..15]	YD:SYS 1	Sets NMEA 2000 system instance (0..15, integer value). Factory setting: 0
YD:PGN [PGN] [0 50..60000]	YD:PGN 126993 60000 YD:PGN 127506 1500 YD:PGN 127508 1500	Sets the transmission interval in PGNs: 126993, 127506 and 127508 (see Appendix B) in milliseconds (50..60000 ms, integer value; 0 turns off periodic transmission). Factory settings are shown as examples.
YD:SVn <ON OFF> [<condition> <time> <bank> <channel>] NEVER	YD:SV1 ON >12 60 0 1	See IX.3 for details.

If you enter a command without arguments, their actual values will be automatically added to the field. For example, if you enter «YD:SHUNT_CUR», the Installation Description field will read «YD:SHUNT_CUR 50». In case you entered an invalid argument value, the command string will be truncated to the valid format, e.g. «YD: SHUNT_CUR 5000» will be transformed to «YD: SHUNT_CUR», «YD: BATTERY 300» to «YD: BATTERY», etc.

3. Setting Digital Switching rules

The Battery Monitor supports NMEA 2000 digital switching equipment (managed with standard PGNs 127501 and 127502). The Device can send commands to turn on/off electrical loads connected to external NMEA 2000 two-state devices (e. g. relay banks).

The commands can be set via configuration file or Installation Description strings. In the latter case, you will need a hardware PC-to-NMEA 2000 gateway and an appropriate software app from Yacht Devices, ActiSense or Maretron; this is also possible on some MFDs (refer to their manufacturer documentation for details). You can set up to three pairs (ON and OFF) of rules for each of the four parameters: voltage, current, temperature, and state of charge. By default, all rules are set to NEVER.

3.1. Setting rules in a configuration file

You may include dedicated lines for setting Digital Switching rules in the YDBM.TXT configuration file using the following format:

```
SXn_a=[c t b ch]|NEVER
```

where:

X – measured or calculated parameter (*V* – voltage in Volts, *C* – current in Amperes, *T* – temperature in Celsius degrees, or *S* – state of charge in percent);

n – rule number (1..3, integer);

a – destination status of the specified Digital Switching channel, ON or OFF;

c – condition (more < or less >), comparison direction and reference parameter value, e.g. «>10»;

t – time period (in seconds) during which the condition must continuously occur (0..65534, integer);

b – Digital Switching bank number (0..252, integer);

ch – Digital Switching channel number (1..28, integer);

NEVER – disables the rule of a specified number and destination status.

Factory setting: NEVER

The rule works the following way: when the measured parameter «X» takes a value that matches the condition «c» continuously during «t» seconds, Digital Switching channel «ch» in Bank «b» changes its status to «a».

Some examples of setting rules by including parameter lines in an YDBM.TXT configuration file:

```
SV1_ON=>12 60 0 1
```

When the measured voltage exceeds 12 V during 60 seconds, rule #1 changes the status of DS Channel #1 at Bank #0 to ON.

```
SC3_OFF=NEVER
```

Disables current-related «OFF» rule #3. You can find more examples in Section IV.

3.2. Setting rules with Installation Description strings

To set Digital Switching rules, you may use the following command formats:

```
YD: SXn <ON|OFF> [<condition> <time> <bank> <channel>] | NEVER
```

where:

X – measured or calculated parameter (*V* – voltage in Volts, *C* – current in Amperes, *T* – temperature in Celsius degrees, or *S* – state of charge in percent);

n – rule number (1..3, integer);

ON|OFF – destination status of the specified Digital Switching channel;

<condition> – comparison direction (more < or less >) and reference parameter value, e.g. «<11»;

<time> – time period (in seconds) during which the condition must continuously occur (0..65534, integer);

<bank> – Digital Switching bank number (0..252, integer);

<channel> – Digital Switching channel number (1..28, integer);

NEVER – disables the rule of a specified number and destination status.

Factory setting: NEVER

This is how the rule works: when the measured parameter «X» takes a value that matches the <condition> continuously during <time> seconds, Digital Switching <channel> that belongs to <bank> changes its status to ON or OFF.

Depending on their channel's destination status, all Digital Switching rules are factory set to «YD: SXn ON NEVER» or «YD: SXn OFF NEVER».

To disable an ON or OFF rule of a specified number, use the following command:

```
YD:SWx <ON|OFF> NEVER
```

To display the ON/OFF pair for the specified rule number, use the command without arguments:

```
YD:SWx
```

More examples of rule setting commands (see the example in IX.3.1):

```
YD:SV1 ON >12 60 0 1
```

When the measured voltage exceeds 12 V during 60 seconds, rule #1 changes the status of DS Channel #1 at Bank #0 to ON.

```
YD:ST3 OFF NEVER
```

Disables temperature-related «OFF» rule #3. You can find more examples in Section IV.

X. Battery Synchronization

1. Partial synchronization

For a reliable readout, the Device's state of charge (SoC) has to be synchronized regularly to the actual state of the battery. This procedure, called Partial Synchronization, is accomplished by fully charging the battery (you don't need to run the Partial Synchronization manually).

The Device recognizes the Battery as fully charged when the following «charged criteria» are met: a) battery voltage exceeds the set Charged Voltage parameter value, and simultaneously b) charging current falls below the set Charged Current value during the c) time period specified as Charged Period value (see Section IX for details). When the Partial Synchronization is finished, the Device's LED indicates this with a series of four GREEN signals (see Section VII), state of charge will be set to 100% and the consumed Ah will be set to 0Ah.

Calculations must be on to perform the Partial Synchronization (command YD:CALCS ON or CALCS=ON in the YDBM.TXT file, see Section IX).

To keep the calculated SoC value credible, we recommend you to perform Partial Synchronization at least once a month. The more frequently you fully charge your battery, the more credible the Device readings.

If the Device does not synchronise automatically, the Charged Voltage, Charged Current, and Charged Period may need adjustment. When the Device has been disconnected from power or the battery, the Partial Synchronization should be done before the Device can operate correctly. Another scenario that requires Partial Synchronization is the first connection of a Device to a battery which is not fully charged.

2. Full synchronization

Full Synchronization updates the state of health (SoH) value. It is long process which requires about 24 hours and special care concerning the discharge current. You should keep the Device connected to both the battery and the NMEA 2000 power source throughout the entire process without a single interruption. Otherwise, you will have to start the procedure again.

It has 6 steps (shown at Figure 1), which are indicated by a special 6-flash LED sequence emitted every 20 seconds (R on the drawing is RED signal, G – GREEN). You can also get know the current state with MicroSD card (see Section IX), first lines of YDBMSAVE.TXT contains the current state of synchronization and the date/time when it was started. Alternatively, you can enter the command YD:FULL_SYNC without parameters or the command YD:SOH (see IX.2).

Calculations must be on to perform the Full Synchronization (command YD:CALCS ON or CALCS=ON in the YDBM.TXT file, see Section IX).

To run the process, enter the command YD:FULL_SYNC ON (see IX.2) or type FULL_SYNC=ON in the YDBM.TXT file (see IX.1). After that, the Device will flash RED-RED-RED-RED-RED-GREEN (RRRRRG) every 20 seconds, and the state will be switched to «Pending». Then you should fully charge your battery (see X.1 for details about full charge) until the flash sequence changed to RRRRGG and the state is switched to «Started».

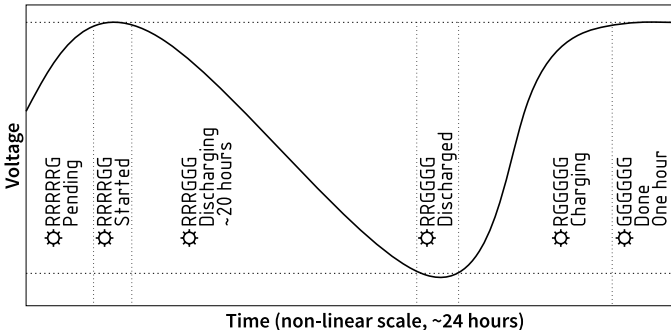

Figure 1. Full synchronization process

At the third step, you should discharge the battery from the fully charged (100% SoC) to the fully discharged state. The discharge current should be equal (or as close as possible) to the following calculated value:

$$I_{dis} = \frac{C}{T}$$

where:

C – battery’s rated capacity in ampere-hours (set for *CAPACITY* parameter, see Section IX),

T – battery’s nominal discharge rate in hours (set for *NOMINAL_RATE*, see Section IX).

Please note that the discharge process can take a significant amount of time (up to *T* hours – see the I_{dis} formula above), which depends on the actual health of your battery (usually the discharge rate *T* is 20 hours).

When battery voltage drops below the Discharge Voltage value (see Table 1 below), the state switches to «Discharged» with the flash sequence RRGGGG. You should start charging the battery as soon as possible after it is fully discharged. To extend the battery’s life, never leave it discharged for a prolonged time period.

Full Synchronization ends when the battery is fully charged (see X.1 for details about full charge), state of health will be updated, state of charge will be set to 100% and the consumed Ah will be set to 0Ah. *FULL_SYNC* will be automatically set to OFF (*YD:FULL_SYNC* or *FULL_SYNC*, see Section IX). The Device’s will emit «Done» flashing sequence (six GREEN flashes) for a period of an hour for your convenience (you don’t need to wait while the Device stops emit this sequence, you can turn the Device off if required).

We recommend performing the Full Synchronization once a year. Full Synchronization is as well required each time you switch on the calculations, or reset the Device, or alter the nominal capacity value in Battery Monitor settings, and then connect the Device to a non-new battery (i.e. with SoH definitely less than 100%).

If you do not need the SoH value, you could just ignore the Full Synchronization. Please note that in this case, the SoH value will remain constant, and will not change unless you perform a Full Synchronization. Moreover, if you use the Device with a battery of more than several years old, and/or the battery was maintained in the incorrect manner (e.g. repeatedly discharged below the specified limit, kept

undercharged for a significant time, etc.), your battery's state of health could drop dramatically. Since this will affect the reliability of SoC calculations, we recommend you to perform a Full Synchronization.

3. Charged and Discharged Voltage values

The default Charged Voltage value is set based on Nominal Voltage according to the table below. If you change the Nominal Voltage setting for your battery, the Charged Voltage value will be set to default. However, you may override the Charged Voltage value with your own setting; otherwise, or if the parameter is set to UNKNOWN, the default value will be used.

Table 1. Charged and Discharged Voltage for different battery types (in Volts).

Nominal Voltage, Volts	Charged voltage	Discharged voltage	
	Lead Acid Lithium Ion	Lead Acid Lithium Ion	NiCd NiMH
6	6.6	5.25	5
12	13.2	10.5	10.8
24	26.4	21	22.8
32	35.2	28	31.2
36	39.6	31.5	34.8

4. Calculations reset

Both SoC and SoH values are set to 100%, and consumed Ah is set to 0 Ah in the following cases:

- you turn calculations ON with CALCS parameter or YD:CALCS command (see Section IX)
- you reset Device settings with CFGRESET parameter or YD:RESET command
- you change Capacity value in CAPACITY parameter or with YD: CAPACITY command

If you connect a battery to a Device whose SoC / SoH is set to 100%, or whose memory contains values calculated for a different battery, the Device readings may not reflect the actual state of the battery. The same may happen when you reconnect the Device to the same battery after a period during

which it was not monitored for some time. To restore credible readings, you have to update parameters according to the actual state of your battery. This can be achieved through the synchronization procedure, partial or full (see X.1 and X.2 for details).

XI. NMEA 2000 Digital Switching Support

To make your system more flexible and scalable, we have added an expert option that makes the Battery Monitor more than just a measurement data source. The Device is capable of managing of NMEA 2000 digital switching equipment by user-defined rules (see IX.3 and examples in Section IV).

Depending on measurement results, the Device can automatically turn on or off any of 28 Digital Switching channels which can activate other connected devices, e.g., raise a sound alert, turn on a battery charging genset, switch off a power consumer, etc.

The Battery Monitor supports NMEA 2000 digital switching equipment that is managed with NMEA 2000 Standard PGNs 127501 and 127502. The Device can send commands to turn on/off electrical loads connected to external NMEA 2000 two-state devices (e. g. relay banks).

Products described in this chapter may become a valuable addition to your digital switching system.

1. Yacht Devices NMEA 2000 Circuit Control YDCC-04

The Circuit Control incorporates one bank of four latching (bi -stable) relays capable of switching direct current (DC) and alternating current (AC) loads. The Battery Monitor can be used to monitor amperage in DC loads connected to the YDCC-04, and automatically turn them ON and OFF depending on user rules. For example, you can set up the Battery Monitor to switch OFF a load when battery current exceeds a pre-defined value, or switch to another battery/bank if the measured voltage drops below the set threshold.

2. Yacht Devices Alarm Button YDAB-01

The Alarm Button acts as a digital switching «music box»; it incorporates a powerful sound amplifier with a loudspeaker output. Battery Monitor can turn ON any of Alarm Button's 28 alarm sounds (preset or user-uploaded). For example, you can automatically activate an alarm when the battery's voltage is running low.

3. Yacht Devices NMEA 2000 Wi-Fi Gateway YDWG-02 or Wi-Fi Router YDNR-02

A Gateway or Router can establish its own Wi-Fi network, or connect to the boat's existing Wi-Fi to transfer marine data to mobile devices and laptops. Both have an internal web server with a special web page called «Web Gauges», which allows viewing vessel data from a standard web browser.

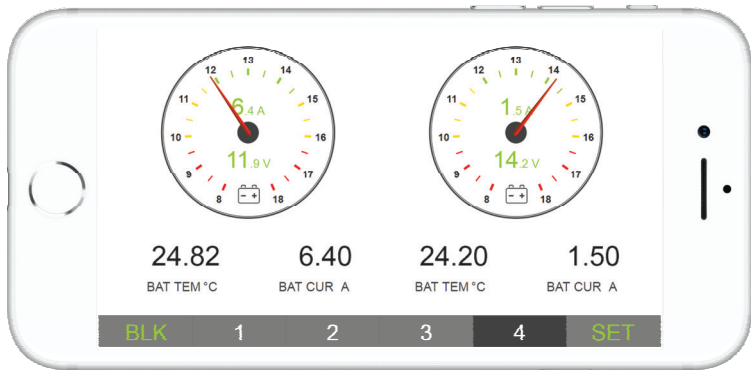

Figure 1. Web Gauges screenshot

The Battery Monitor's data can be displayed with circular gauges or text data bars used for batteries (see Figure 1). If you have external access to your boat's network, Web Gauges is an ideal solution for remote monitoring of your boat.

4. Yacht Devices NMEA 2000 Ethernet Gateway YDEN-02

This device connects NMEA 2000 network to Ethernet networks, and, like our Wi-Fi products, it (see XI.3) provides Web Gauges and can be used to manage NMEA 2000 devices with CAN Log Viewer software (see IX.2).

5. Third-party NMEA 2000 Digital Switching equipment

Battery Monitor can turn ON and OFF electrical loads connected to third-party NMEA 2000 digital switching equipment managed with NMEA 2000 Standard PGN 127501 and 127502. The Device is compatible with Oceanic Systems, Offshore Systems, Maretron and Carling Tech relay modules (a special setting is required for Maretron and Carling Tech products, see Note 1 for Table 1 in IX.1).

The Device cannot be used to control CZone or EmpirBus modules; they use proprietary protocols and cannot be managed with standard NMEA 2000 messages.

XII. Firmware Updates

Copy an appropriate update file (OUPDATE.BIN) to the root folder of a MicroSD card formatted with FAT or FAT32 file system.

Power off your NMEA 2000 network, insert the card into the Device, and power the network back on.

In 5 to 10 seconds, a series of 5 GREEN LED signals will follow, indicating that the firmware is successfully updated.

At any time, you can download the most recent version of the Battery Monitor firmware from the Downloads section of our website: <http://www.yachtd.com/downloads/>

If the Device has the same firmware version already installed, or the update file is corrupted, the Battery Monitor automatically returns to normal operation.

You can check the firmware version:

- with an MFD -- in the list of external NMEA 2000 devices;
- via dedicated NMEA 2000 viewing software (in particular, Yacht Devices' CAN Log Viewer) in Device Properties;
- in a YDBMSAVE.TXT file which is created on the MicroSD card each time you successfully load an YDBM.TXT file into the Device (see first lines in Appendix C).

If there is a YDBM.TXT file present on your MicroSD card, a further series of three signals relates to loading a new configuration, as described in Section VII «LED Signals».

Appendix A. Troubleshooting

Situation	Possible causes and solutions
No LED indication after the NMEA 2000 network is powered on.	<p>1. No power supply on the NMEA 2000 bus. Check if the bus power is supplied (an NMEA 2000 network requires a separate power connection, it cannot be powered from a chart plotter or another device connected to the network).</p> <p>2. Loose connection in the NMEA 2000 power supply circuit. Apply contact cleaner spray to the Device connector, and/or plug the Device into another outlet.</p>
The Device LED is continuously giving 1-second red flashes.	<p>1. Device cannot get NMEA 2000 device address. There are more than 252 NMEA devices already in the NMEA 2000 network. Consider using our NMEA 2000 Bridge YDNB-07 to divide your network into separate segments.</p>
No three green blinks on powering on. The Device produces a short green LED blink corresponding to the every third transmission of PGN 127508 «Battery Status» (see IX), but it does not appear in the list of external devices on the plotter. No data comes from the Device.	<p>1. Loose connection in the data circuit. Apply contact cleaner spray to the Device connector, and/or plug the Device into another outlet.</p> <p>2. NMEA 2000 network problems. The network segment is not connected to the plotter, or some terminator(s) are missing in the network. Plug another device into the selected connector, and make sure it appears in the list of devices on the plotter.</p>

Situation	Possible causes and solutions
Missing, unstable or inaccurate current/voltage readings.	<p>1. Loose connection to the monitored battery. Check the connections, apply contact cleaner spray where necessary.</p> <p>2. Improper wiring. Double check all connections to the battery, in particular, for having a common ground wire connected to the Device's black wire (see VI.1).</p> <p>3. Too long or thin cables. Inaccurate readings may occur because of excessive voltage drop in cables. Make sure to use appropriate wire gauge (see Figure 1 in section VI.1).</p> <p>4. Wrong shunt settings. Check and correct your shunt settings.</p>
Negative current values are displayed upon charging the battery, positive upon discharging.	<p>1. Improper wiring to the shunt. Double check all connections to the shunt.</p>
No current/voltage data on the chartplotter	<p>1. Incompatible chartplotter. Your chartplotter does not support PGN 127506 nor PGN 127508. Check your MFD manufacturer's website for a firmware update.</p>
Missing, unstable or inaccurate temperature readings.	<p>1. Battery temperature measuring device fails to supply data. The device may go offline, or malfunction. Check its NMEA 2000 connection, and refer to its User Manual if necessary.</p>
No temperature data on a chartplotter	<p>1. Incompatible chartplotter. Your MFD does not support displaying battery temperature. As a workaround, you can set data type supported by MFD in the settings of your temperature sensor.</p>

Situation	Possible causes and solutions
Digital switching rules do not work as expected	<p>1. Wrong bank number. Check and match bank numbers across connected devices.</p> <p>2. Incorrect settings or rules. Check Device settings and active rules via the YDBMSAVE.TXT file, or with Can Log Viewer (see IX.2).</p>
The Device LED is continuously giving 1-second red flashes.	<p>1. Make sure that CALCS is ON. See CALCS parameter or YD:CALCS command in Section IX.</p> <p>2. Make sure your chartplotter supports PGN 127506 «DC Detailed Status».</p>
Incorrect SoC readings	<p>1. Battery is not synchronized after a prolonged period in operation.</p> <p>2. Battery reconnected after being used separately with a noticeable loss of charge.</p> <p>3. (if a new battery is connected) The battery has partially lost its charge.</p> <p>In any of the 3 cases, perform a Partial Synchronization (see Section X).</p> <p>4. NiCd or NiMH battery (see Section III for details).</p>
Device does not recognize fully charged state when battery charging is finished (no LED signals, Partial Synchronization date is not updated)	<p>1. Unsuitable settings related to fully charged state. Revise and adjust CHARGED_VOL, CHARGED_CUR, and CHARGED_PERIOD parameters. You may also adjust the CHARGE_EFF value. This adjustment may require several iterations: if no LED signals appear after the charging is finished, partially discharge the battery and charge it again; repeat this step if necessary.</p>

Appendix B. Supported NMEA 2000 Messages

Message name	PGN #	Receive	Transmit	Transmission interval, sec
Acknowledge	59392	Yes	Yes	—
ISO Request	59904	Yes	—	—
ISO Transport Protocol (DT)	60160	Yes	—	—
ISO Transport Protocol (CM)	60416	Yes	—	—
ISO Address Claim	60928	Yes	Yes	—
ISO Commanded Address	65240	Yes	—	—
NMEA Group Function	126208	Yes	Yes	—
PGN List	126464	—	Yes	—
System Time	126992	Yes	—	—
Heartbeat	126993	—	Yes	60
Product Information	126996	—	Yes	—
Configuration Information	126998	—	Yes	—
Binary Status Report	127501	Yes	—	—
Switch Bank Control	127502	—	Yes	—
DC Detailed Status	127506	—	Yes	1.5
Battery Status	127508	—	Yes	1.5
Battery Configuration Status	127513	—	Yes	(Note 1)
GNSS Position Data	129029	Yes	—	—
Temperature	130312	Yes	—	—

Table continued

Message name	PGN #	Receive	Transmit	Transmission interval, sec
Temperature, Extended Range	130316	Yes	—	—

Note 1: this PGN is transmitted immediately after PGN 127506 «DC Detailed Status».

Appendix C. Example of Configuration File

All parameter values listed below correspond to factory settings.

```
# Current configuration of YDBM-01 Battery Monitor
# Firmware version: 1.00 19/10/2020
# Current Date: 01.11.2020 14:20:32 UTC
# Status: voltage +12.10V, current +0.0A, temperature is not available.

# Calculations (SOC, consumed AH, time remaining, and SOH) (ON|OFF)
CALCS=OFF

# State of Charge: not available. Calculations are off.
# State of Health: not available. Calculations are off.
# Consumed Amp Hours: not available. Calculations are off.

# FULL SYNCHRONIZATION INFORMATION

# Full Synchronization (ON|OFF)
FULL_SYNC=OFF

# SHUNT SETTINGS

# Shunt Current (A)
SHUNT_CUR=50

# Shunt Voltage Drop (mV)
SHUNT_VOL=75

# BATTERY SETTINGS
```

```
# Battery Instance
BATTERY=0

# Temperature Instance
TEMPERATURE=UNKNOWN

# DC type (BATTERY|ALTERNATOR|CONVERTOR|SOLAR_CELL|WIND_GENERATOR)
DC_TYPE=BATTERY

# Capacity (AH)
CAPACITY=100

# Nominal Battery Voltage
NOMINAL_VOL=12

# Charged Battery Voltage (V)
# One of the 3 charged criteria:
# The battery voltage should be above this value to consider the battery fully charged.
CHARGED_VOL=13.2

# Charged Current (% of the battery capacity)
# One of the 3 charged criteria:
# If the charge current drops below this value, the battery is considered as fully charged.
CHARGED_CUR=4.0

# Charged Period (min)
# One of the 3 charged criteria:
# Charged criteria Charged Voltage and Charged Current must be met
# for this interval of time to consider battery as fully charged.
CHARGED_PERIOD=3
```

```
# Nominal Discharge Rate (hours) for specified battery capacity
NOMINAL_RATE=20

# Discharged Battery Voltage (V)
# is set automatically.
# If the battery voltage drops below this value, battery is considered as fully discharged.
DISCHARGED_VOLTAGE=10.5

# Battery type (FLOODED|GEL|AGM|UNKNONN)
BATTERY_TYPE=FLOODED

# Equalization support
# Indicates if the battery supports equalization.
EQUALIZ_SUPPORT=UNKNOWN

# Battery Chemistry (LEAD_ACID|LI_ION|NICAD|ZNO|NIMH)
CHEMISTRY=LEAD_ACID

# Temperature Coefficient (%/C)
TEMP_COEF=0.0

# Peukert's Exponent
PEUKERT=1.25

# Charge Efficiency Factor (%)
CHARGE_EFF=95

# DIGITAL SWITCHING

# Maretron digital switching mode (ON|OFF)
MARETRON=OFF
```

Digital Switching Rules

SV1_ON=NEVER

SV1_OFF=NEVER

SV2_ON=NEVER

SV2_OFF=NEVER

SV3_ON=NEVER

SV3_OFF=NEVER

SC1_ON=NEVER

SC1_OFF=NEVER

SC2_ON=NEVER

SC2_OFF=NEVER

SC3_ON=NEVER

SC3_OFF=NEVER

ST1_ON=NEVER

ST1_OFF=NEVER

ST2_ON=NEVER

ST2_OFF=NEVER

ST3_ON=NEVER

ST3_OFF=NEVER

SS1_ON=NEVER

SS1_OFF=NEVER

SS2_ON=NEVER

SS2_OFF=NEVER

SS3_ON=NEVER

SS3_OFF=NEVER

End of file

