

# INSTALLATION INSTRUCTIONS PLUS – EASYSTART / ALTITUDE KIT, SPECIAL FUNCTIONS AND DIAGNOSTICS



## THE INSTALLATION INSTRUCTIONS PLUS APPLIES TO THE FOLLOWING CONTROL UNITS AND MOUNTING PARTS:

CONTROL UNITS	ORDER NO.
EASYSTART TIMER, 12 /24 V	22 1000 34 15 00
EASYSTART REMOTE+, 12 /24 V	22 1000 34 17 00
EASYSTART REMOTE, 12 /24 V	22 1000 34 23 00
EASYSTART SELECT, 12 /24 V	22 1000 34 13 00
EASYSTART CALL, 12 /24 V	22 1000 34 01 00

### ALTITUDE KIT

Altitude kit / altitude sensor, 12 /24 V 22 1000 33 22 01

# CONTENTS

## CHAPTER

1	Introduction	
	Foreword	4
	Special text structure, presentation and picture symbols	4
	▪ Special text formats and presentations	4
	▪ Picture symbols	4
	Control unit documentation	5
	Further documentation	5
	Liability claim / Warranty	5
	Accident prevention	5
2	Usability	
	EasyStart control unit ▶ heater usability	6
	EasyStart control unit ▶ heater usability in ADR mode	7
	EasyStart control unit ▶ heater and altitude kit ▶ heater usability	8
	Allowable combinations of the EasyStart control units	9
3	Product Information	
	EasyStart Timer	10
	▪ Overview of the functions that can be executed in parallel	10
	EasyStart Remote+	11
	▪ Overview of the functions that can be executed in parallel	11
	EasyStart Remote	12
	▪ Overview of the functions that can be executed in parallel	12
	EasyStart Select	13
	▪ Overview of the functions that can be executed in parallel	13
	EasyStart Call	14
	▪ Overview of the functions that can be executed in parallel	14
	Altitude kit	15
	▪ Intended use	15

# CONTENTS

4	Installation	
	Allowable heater combinations	16
	Options	17
	Special functions	17
	EasyStart Timer / Remote+ workshop menu	19
	▪ Service functions overview	19
	EasyStart Select vehicle workshop menu	22
	▪ Service functions overview	22
	EasyStart Call – diagnosis	24
	EasyStart Call – App manual	25
	Altitude kit – diagnosis	29
5	Circuit diagram	
	Overview of the circuit diagrams	30
	<u>EasyStart Timer</u>	
	▪ <u>Combined control units</u>	
	▪ <u>Special functions</u>	
	▪ <u>ADR mode</u>	
	▪ <u>ADR mode with combined control units</u>	
	Overview of the circuit diagrams	65
	<u>EasyStart Remote+</u>	
	▪ <u>Combined control units</u>	
	▪ <u>Special function</u>	
	Overview of the circuit diagrams	85
	<u>EasyStart Remote / Select / Call / Altitude kit / Special functions</u>	

# 1 INTRODUCTION

## FOREWORD

These Installation Instructions are applicable to the control units and mounting parts listed on the title page, to the exclusion of all liability claims.

These installation instructions contain the following for the control units and mounting parts:

- the complete vehicle workshop menu,
- special functions, e.g. combinations of different EasyStart control units,
- installation in ADR vehicles,
- installation of an add-on unit,
- diagnostics query with the control units,
- all circuit diagrams.

Depending on the version or modification status of the control units/ mounting parts, differences from these installation instructions may occur.

The user must check this before carrying out the installation work and, if necessary, take the differences into account.

## SPECIAL TEXT STRUCTURE, PRESENTATION AND PICTURE SYMBOLS

Special text formats and picture symbols are used in these instructions to emphasise different situations and subjects. Please refer to the following examples for their meanings and appropriate action.

### SPECIAL TEXT FORMATS AND PRESENTATIONS

- This dot (▪) indicates a list, which is introduced by a heading.
  - If an indented dash (–) follows a “dot”, this list is a sub-section of the black dot.

Underlined blue text denotes a cross-reference, which can be clicked in the PDF format. The part of the document named in the text is then displayed.

### PICTURE SYMBOLS



**DANGER!**

This information points out a potential serious or fatal danger. Ignoring this information can result in severe injuries.

- ➔ This arrow indicates the appropriate precaution to take to avert the danger.



**ATTENTION!**

This information points out a dangerous situation for a person and / or the product. Failure to comply with this information can result in injuries to people and / or damage to the unit.

- ➔ This arrow indicates the appropriate precaution to take to avert the danger.



**PLEASE NOTE!**

These remarks contain recommendations for use and useful tips for the operation, installation and repair of the heater.

# 1 INTRODUCTION

## CONTROL UNIT DOCUMENTATION

The contents and purpose of these installation instructions help you when installing a control unit and to correct a fault. The work required for this may only be done by personnel appropriately trained by a JE service partner.

## FURTHER DOCUMENTATION

Apart from these Installation Instructions Plus there are corresponding operating and installation instructions for control units and mounting parts, as well as quick start guides for the EasyStart Timer and EasyStart Remote<sup>+</sup>. This documentation provides JE service partners with all the necessary technical information, describes proper installation and provides the customer with the necessary information for safe operation of the control unit.

## LIABILITY CLAIM / WARRANTY

Eberspächer Climate Control Systems GmbH & Co. KG does not accept any liability whatsoever for defects and damage, which are due to installation or repair by unauthorised and untrained persons.

Compliance with the official regulations and the safety instructions is prerequisite for liability claims.

Failure to comply with the official regulations and safety instructions leads to exclusion of any liability of the heater manufacturer.

## ACCIDENT PREVENTION

General accident prevention regulations and the corresponding workshop and operating safety instructions are to be observed.

### PLEASE NOTE!

- The relevant rules of sound engineering practice and any information provided by the vehicle manufacturer are to be observed during the installation and repair.
  - Before starting any work, disconnect the positive (+) battery cable and earth it (connect it to the vehicle frame).
-

## 2 USABILITY

### EASYSTART CONTROL UNIT ► HEATER USABILITY

The following table shows the use options of EasyStart control units with Eberspächer air and water heaters.

Version number and status of the heaters [see page 8](#).

EASYSTART control unit	Heater type	Voltage	Comment
<ul style="list-style-type: none"> <li>– TIMER</li> <li>– REMOTE+</li> <li>– SELECT</li> <li>– CALL</li> </ul>	Airtronic / Airtronic M	12 VOLT / 24 VOLT	<ul style="list-style-type: none"> <li>– from heaters with the automatic altitude adjustment function*</li> <li>– Switch-on signal via diagnostics cable</li> <li>– Ventilation mode possible</li> </ul>
<ul style="list-style-type: none"> <li>– TIMER</li> <li>– REMOTE+</li> <li>– SELECT</li> <li>– CALL</li> </ul>	Airtronic L	12 VOLT / 24 VOLT	<ul style="list-style-type: none"> <li>– from heaters with the automatic altitude adjustment function*</li> <li>– Switch-on signal via diagnostics cable</li> <li>– Ventilation mode possible</li> </ul>
<ul style="list-style-type: none"> <li>– TIMER</li> <li>– REMOTE+</li> <li>– REMOTE</li> <li>– SELECT</li> <li>– CALL</li> </ul>	Hydronic	12 VOLT	<ul style="list-style-type: none"> <li>– from heaters with the automatic altitude adjustment function*</li> <li>– Switch-on signal via diagnostics cable</li> <li>– Ventilation mode possible</li> </ul>
<ul style="list-style-type: none"> <li>– TIMER</li> <li>– REMOTE+</li> </ul>	Hydronic	24 VOLT	<ul style="list-style-type: none"> <li>– Switch-on signal via S+</li> <li>– Diagnosis is not possible via the control unit</li> </ul>
<ul style="list-style-type: none"> <li>– TIMER</li> <li>– REMOTE+</li> <li>– CALL</li> </ul>	Hydronic auxiliary heater	12 VOLT	<ul style="list-style-type: none"> <li>– only with JE diagnosis</li> <li>– Switch-on signal via diagnostics cable</li> </ul>
<ul style="list-style-type: none"> <li>– TIMER</li> <li>– REMOTE+</li> </ul>	Hydronic auxiliary heater	12 VOLT	<ul style="list-style-type: none"> <li>– without JE diagnosis</li> <li>– Upgrade box necessary,</li> <li>– Diagnosis is not possible via the control unit</li> </ul>
<ul style="list-style-type: none"> <li>– TIMER</li> <li>– REMOTE+</li> <li>– REMOTE</li> <li>– SELECT</li> <li>– CALL</li> </ul>	Hydronic II <ul style="list-style-type: none"> <li>– Eco</li> <li>– E-Mobility</li> <li>– Comfort</li> </ul>	12 VOLT	<ul style="list-style-type: none"> <li>– Switch-on signal via diagnostics cable</li> <li>– Ventilation mode possible</li> </ul>
<ul style="list-style-type: none"> <li>– TIMER</li> <li>– REMOTE+</li> <li>– REMOTE</li> <li>– SELECT</li> <li>– CALL</li> </ul>	Hydronic II C (COMMERCIAL)	12 VOLT / 24 VOLT	<ul style="list-style-type: none"> <li>– Switch-on signal via diagnostics cable</li> </ul>
<ul style="list-style-type: none"> <li>– TIMER</li> <li>– REMOTE+</li> <li>– REMOTE</li> <li>– SELECT</li> <li>– CALL</li> </ul>	Hydronic M II	12 VOLT / 24 VOLT	<ul style="list-style-type: none"> <li>– Switch-on signal via diagnostics cable</li> </ul>
<ul style="list-style-type: none"> <li>– TIMER</li> <li>– REMOTE+</li> </ul>	Hydronic L II	24 VOLT	<ul style="list-style-type: none"> <li>– Switch-on signal via S+</li> <li>– Diagnosis is not possible via the control unit</li> </ul>

\* Heater with the “automatic altitude adjustment” function.

**Identifying feature:** From production in summer 2008 “H-Kit” is marked on the heater's nameplate.

## 2 USABILITY

### EASYSTART CONTROL UNIT ► HEATER USABILITY IN ADR MODE

The following table shows the use options of EasyStart control units with Eberspächer air and water heaters in **ADR mode**.

Version number and status of the heaters [see page 8](#).

EASYSTART control unit	Heater type	Voltage	Comment
– TIMER	Airtronic / Airtronic M	12 VOLT / 24 VOLT	– from heaters with the automatic altitude adjustment function* – Switch-on signal via diagnostics cable – Ventilation mode possible
– TIMER	Airtronic L	12 VOLT / 24 VOLT	– from heaters with the automatic altitude adjustment function* – Switch-on signal via diagnostics cable – Ventilation mode possible
– TIMER	Hydronic II C (COMMERCIAL)	12 VOLT / 24 VOLT	– Switch-on signal via diagnostics cable
– TIMER	Hydronic M II	12 VOLT / 24 VOLT	– Switch-on signal via diagnostics cable

\* Heater with the automatic altitude adjustment function.

**Identifying feature:** From production in summer 2008 “H-Kit” is marked on the heater's nameplate.

#### **PLEASE NOTE!**

The control unit is connected directly to the heater.

- Hydronic series heaters without JE diagnosis can only be controlled via the “AD Add-on Unit” menu item or via “Switch-on signal S+”.  
Diagnosis via the control unit is not possible with either of the two variants.
- Airtronic series heaters can be controlled via the “Switch-on signal S+”; however, the heaters need a further control unit to set the temperature setpoint.

## 2 USABILITY

### EASYSTART CONTROL UNIT ► HEATER AND ALTITUDE KIT ► HEATER USABILITY

The following tables list the Eberspächer air and water heater types with version number and status, which are suitable for use with EasyStart control units.

Connection of the control units via the diagnostics cable

#### AIR HEATERS

HEATER TYPE	VERSION NUMBER	FROM STATUS
<b>Airtronic</b>		
D2 – 12V	25 2069 05 00 00	.0P
D2 – 12V	25 2115 05 00 00	.0Q
D2 – 24V	25 2070 05 00 00	.00
D2 – 24V	25 2116 05 00 00	.0Q
Use of altitude kit is possible*		
<b>Airtronic M</b>		
D3 – 12V	25 2317 05 00 00	.0J
B4 – 12V	20 1812 05 00 00	.0D
D4 – 12V	25 2113 05 00 00	.0P
D4 – 24V	25 2114 05 00 00	.00
D4 Plus – 12V	25 2484 05 00 00	.0C
D4 Plus – 24V	25 2498 05 00 00	.0A
Use of altitude kit is possible*		
<b>Airtronic L</b>		
B5 12V	20 1859 05 00 00	.0F
D5 12V	25 2361 05 00 00	.0G
D5 24V	25 2362 05 00 00	.0G
Use of altitude kit is possible*		

#### WATER HEATERS

HEATER TYPE	VERSION NUMBER	FROM STATUS
<b>HYDRONIC</b>		
B4W S – 12V	20 1866 05 00 00	.0F
B4W S – 12V	20 1819 05 00 00	.0G
B4W S – 12V	20 1852 05 00 00	.0B
B5W S – 12V	20 1862 05 00 00	.0F
D4W S – 12V	25 2418 05 00 00	.0E
D4W S – 12V	25 2355 05 00 00	.0B
D5W S – 12V	25 2386 05 00 00	.0D
D5W S – 12V	25 2217 05 00 00	.0D
B4W SC – 12V	20 1824 05 00 00	.0E

HEATER TYPE	VERSION NUMBER	FROM STATUS
B4W SC – 12V	20 1861 05 00 00	.0E
B5W SC – 12V	20 1820 05 00 00	.0F
B5W SC – 12V	20 1863 05 00 00	.0E
D4W SC – 12V	25 2257 05 00 00	.0E
D4W SC – 12V	25 2385 05 00 00	.0E
D5W SC – 12V	25 2219 05 00 00	.0D
D5W SC – 12V	25 2390 05 00 00	.0D
D5W S – 24V	25 2218 05 00 00	.0A
D5W SC – 24V	25 2147 05 00 00	.0A
Use of altitude kit is possible*		

#### HYDRONIC II

Economy	all versions	
E-Mobility (Ethanol)	all versions	
Comfort	all versions	
Use of altitude kit is possible*		

#### HYDRONIC II C

Commercial	all versions	
Use of altitude kit is possible*		
<b>HYDRONIC M-II</b>	all versions	
<b>Use of altitude kit is not necessary, heater is suitable for operation at high altitudes!</b>		

\* heaters with the automatic altitude adjustment function, identifiable from production in summer 2008 as they have "H-Kit" marked on the heater's nameplate.

#### PLEASE NOTE!

Heaters that are not listed can possibly be controlled via the switch-on signal S+; in addition the setpoint for air heaters must be set using a separate control unit.

For circuit diagrams see [from page 30](#).



## 2 USABILITY

### ALLOWABLE COMBINATIONS OF THE EASYSTART CONTROL UNITS

MASTER CONTROL UNIT	SLAVE CONTROL UNITS	COMMENT
Timer with	Timer	Both control units have the same functional scope.
Timer with	Remote	Limited functional scope via remote.
Timer with	Select	Limited functional scope via select.
Timer with	Button	Limited functional scope via button.
Timer in ADR mode, with	Timer	Both control units have the same functional scope.
Timer in ADR mode, with	Select	Limited functional scope via select.
Timer in ADR mode, with	Button	Limited functional scope via button.
Remote+ with	Timer	Both control units have the same functional scope.
Remote+ with	Select	Limited functional scope via select.

#### PLEASE NOTE!

- The **MASTER** control unit is connected directly to the heater.
- The **SLAVE** control unit is connected to the master control unit.
- An impermissible combination is indicated by



for Timer and Remote+





for Select



for Remote

LED flashes red

- The mobile unit of the EasyStart Remote+ cannot be operated with the stationary EasyStart Remote unit. During “teaching” (programming), “no communication”  is displayed at the mobile unit of the EasyStart Remote+.
- Combination of the mobile unit of the EasyStart Remote with the stationary unit of the EasyStart Remote+ is allowed.
- In the case of air heaters the EasyStart Remote can only be operated in conjunction with a 2nd control unit for setting the setpoint, otherwise an **ERROR** is indicated by the red flashing of the LED  during automatic detection.
- The circuit diagrams [from page 30](#) always relate to the master control unit, even in the case of combinations.

### 3 PRODUCT INFORMATION

#### EASystart TIMER

Order No. 22 1000 34 15 00



#### TECHNICAL DATA

Rated voltage	12 volt / 24 volt
Operating voltage range	9 – 32 volt
Dimensions	W: 82 mm, H: 37 mm, D: 12 mm
allowable ambient temperature	– 40 °C to +85 °C
LCD ambient temperature	The display becomes sluggish in temperatures below –10 °C, i.e. the flashing sequence of the symbols is somewhat slower, the contrast becomes weaker above +70 °C.
Accessory temperature sensor	Order no. 22 1000 34 22 00
Cover frame for flush mounting	Order no. 22 1000 51 41 00
Installation location	Vehicle interior
Automatic operating time calculation	possible with temperature sensor
Preset	3 memory locations for preset times within 7 days
Operating time (default)	<ul style="list-style-type: none"> <li>▪ 30 min. for water heaters</li> <li>▪ continuous heating for air heaters</li> </ul>

#### OVERVIEW OF THE FUNCTIONS THAT CAN BE EXECUTED IN PARALLEL

##### EASystart TIMER

	HEAT	VENTILATE	AD HEAT	AD VENTILATE	AD S+	HEAT S+	AUXILIARY HEATER UPGRADE	ROOM TEMPERATURE CONTROL S+ (water heater)	ADR MODE	ALB Automatic operating time calculation	START TIME	DEPARTURE TIME	TIMER PROGRAMMING	OPERATING TIME / TERMINAL 15	TEMPERATURE SENSOR	BUTTON	OPERATING TIME > 120 MINUTES	UNDERVOLTAGE DETECTION, CONTROL UNIT
HEAT	1																	
VENTILATE		1																
AD HEAT			1															
AD VENTILATE				1														
AD S+					1													
HEAT S+						1												
AUXILIARY HEATER UPGRADE							1											
ROOM TEMPERATURE CONTROL S+ (water heater)								1										
ADR MODE									1									
ALB Automatic operating time calculation										1								
START TIME											1							
DEPARTURE TIME												1						
TIMER PROGRAMMING													1					
OPERATING TIME / TERMINAL 15														1				
TEMPERATURE SENSOR															1			
BUTTON																1		
OPERATING TIME > 120 MINUTES																	1	
UNDERVOLTAGE DETECTION, CONTROL UNIT																		1

- 1 Function is simultaneously visible in the menu, but cannot be executed simultaneously.
- 2 ADR signals are prioritised
- 3 Temperature sensor is absolutely necessary
- 4 with the 1st heater
- 5 only switching off is possible

#### PLEASE NOTE!

In the vehicle workshop menu, functions that are mutually exclusive are deactivated.

### 3 PRODUCT INFORMATION

#### EASYSTART REMOTE+

Order No. 22 1000 34 17 00



#### TECHNICAL DATA

MOBILE UNIT	
Frequency	434.6 MHz
Operating voltage	3 volt battery (round cell battery CR2430)
Dimensions	W: 41 mm, H: 66 mm, D: 16 mm
Operating temperature	- 20 °C to 60 °C
Storage temperature	- 40 °C to +85 °C
LCD ambient temperature	The display becomes sluggish in temperatures below -10 °C, i.e. the flashing sequence of the symbols is somewhat slower, the contrast becomes weaker above +70 °C.
STATIONARY UNIT	
Frequency	434.6 MHz
Operating voltage	12 volt / 24 volt
Dimensions	W: 76 mm, H: 76 mm, D: 29 mm
Operating / storage temperature	- 40 °C to +85 °C
Antenna connection	Via coded SMB connector
Installation location	Vehicle interior
Automatic operating time calculation	possible with temperature sensor
Preset	3 memory locations for preset times within 7 days
Operating time (default)	<ul style="list-style-type: none"> <li>▪ 30 min. for water heaters</li> <li>▪ continuous heating for air heaters</li> </ul>

#### OVERVIEW OF THE FUNCTIONS THAT CAN BE EXECUTED IN PARALLEL

##### EASYSTART REMOTE+

	HEAT	VENTILATE	AD HEAT	AD VENTILATE	AD S+	HEAT S+	AUXILIARY HEATER UPGRADE	ROOM TEMPERATURE CONTROL S+ (water heater)	ADR MODE	ALB Automatic operating time calculation	START TIME	DEPARTURE TIME	TIMER PROGRAMMING	OPERATING TIME / TERMINAL 15	TEMPERATURE SENSOR	BUTTON	OPERATING TIME > 120 MINUTES	UNDERVOLTAGE DETECTION, CONTROL UNIT
HEAT	HEAT																	
VENTILATE	1	VENTILATE																
AD HEAT	•	•	AD HEAT															
AD VENTILATE	•	•	1	AD VENTILATE														
AD S+	•	•			AD S+													
HEAT S+	•					HEAT S+												
AUXILIARY HEATER UPGRADE	•		•				AUXILIARY HEATER UPGRADE											
ROOM TEMPERATURE CONTROL S+ (water heater)	•		4					ROOM TEMPERATURE CONTROL S+ (water heater)										
ADR MODE								ADR MODE										
ALB Automatic operating time calculation	•								ALB Automatic operating time calculation									
START TIME	•	•	•	•	•	•	•	•		START TIME								
DEPARTURE TIME	•	•	•	•	•	•	•	•	•		DEPARTURE TIME							
TIMER PROGRAMMING	•	•	•	•	•	•	•	•	•			TIMER PROGRAMMING						
OPERATING TIME / TERMINAL 15													OPERATING TIME / TERMINAL 15					
TEMPERATURE SENSOR	•	•	•	•	•	•	•	•	•					TEMPERATURE SENSOR				
BUTTON	•	5	5	5	5	5	•	•	•						BUTTON			
OPERATING TIME > 120 MINUTES																	OPERATING TIME > 120 MINUTES	
UNDERVOLTAGE DETECTION, CONTROL UNIT																		UNDERVOLTAGE DETECTION, CONTROL UNIT

- 1 Function is simultaneously visible in the menu, but cannot be executed simultaneously.
- 3 Temperature sensor is absolutely necessary
- 4 with the 1st heater
- 5 only switching off is possible

#### PLEASE NOTE!

In the vehicle workshop menu, functions that are mutually exclusive are deactivated.

### 3 PRODUCT INFORMATION

#### EASYSTART REMOTE

Order No. 22 1000 34 23 00



#### TECHNICAL DATA

MOBILE UNIT	
Frequency	434.6 MHz
Operating voltage	3 volt battery (round cell battery CR2032)
Dimensions	W: 34 mm, H: 54 mm, D: 13 mm
Operating temperature	– 20 °C to +60 °C
Storage temperature	– 40 °C to +85 °C
STATIONARY UNIT	
Frequency	434.6 MHz
Operating voltage	12 volt / 24 volt
Dimensions	W: 76 mm, H: 76 mm, D: 29 mm
Operating / storage temperature	– 40 °C to +85 °C
Antenna connection	Via coded SMB connector
Installation location	Vehicle interior
Operating time (default)	30 min.

#### OVERVIEW OF THE FUNCTIONS THAT CAN BE EXECUTED IN PARALLEL

##### EASYSTART REMOTE

	HEAT	VENTILATE	AD HEAT	AD VENTILATE	AD S+	HEAT S+	AUXILIARY HEATER UPGRADE	ROOM TEMPERATURE CONTROL S+ (water heater)	ADR MODE	ALB Automatic operating time calculation	START TIME	DEPARTURE TIME	TIMER PROGRAMMING	OPERATING TIME / TERMINAL 15	TEMPERATURE SENSOR	BUTTON	OPERATING TIME > 120 MINUTES	UNDERVOLTAGE DETECTION, CONTROL UNIT
HEAT	■																	
VENTILATE	1 ■	■	AD HEAT	AD VENTILATE														
AD HEAT			■	AD VENTILATE	AD S+													
AD VENTILATE				■	AD S+													
AD S+					■	HEAT S+												
HEAT S+						■	AUXILIARY HEATER UPGRADE											
AUXILIARY HEATER UPGRADE							■	ROOM TEMPERATURE CONTROL S+ (water heater)										
ROOM TEMPERATURE CONTROL S+ (water heater)								■	ADR MODE									
ADR MODE									■	ALB Automatic operating time calculation								
ALB Automatic operating time calculation										■	START TIME							
START TIME											■	DEPARTURE TIME						
DEPARTURE TIME												■	TIMER PROGRAMMING					
TIMER PROGRAMMING													■	OPERATING TIME / TERMINAL 15				
OPERATING TIME / TERMINAL 15														■	TEMPERATURE SENSOR			
TEMPERATURE SENSOR															■	BUTTON		
BUTTON																■	OPERATING TIME > 120 MINUTES	
OPERATING TIME > 120 MINUTES																	■	UNDERVOLTAGE DETECTION, CONTROL UNIT
UNDERVOLTAGE DETECTION, CONTROL UNIT																		■

1 Function is simultaneously visible in the menu, but cannot be executed simultaneously.  
 5 only switching off is possible

#### PLEASE NOTE!

In the vehicle workshop menu, functions that are mutually exclusive are deactivated.



### 3 PRODUCT INFORMATION

#### EASYSTART CALL

Order No. 22 1000 34 15 00

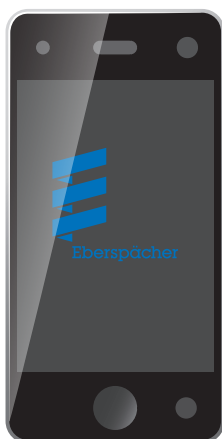

#### TECHNICAL DATA

Operating voltage range	9 – 32 volt
Input voltage	max. 32 volt
Closed-circuit power consumption	0.005 A
Power consumption – data transfer and connection to the GSM network	max. 0.5 A
Dimensions (without fixing tabs)	W: 77 mm, H: 106 mm, D: 25 mm
allowable ambient temperature (with SIM card*)	– 40 °C to +85 °C
Storage temperature (without SIM card)	– 40 °C to +85 °C
GSM Quad Band	EGSM 850 / 900 / 1800 / 1900 MHz
Transmit Power	Class 4 (2W) @ 850 / 900 MHz Class 1 (1W) @ 1800 / 1900 MHz
Installation location	Vehicle interior

\* Note the allowable ambient temperature of the SIM card.

#### OVERVIEW OF THE FUNCTIONS THAT CAN BE EXECUTED IN PARALLEL

##### EASYSTART CALL

	HEAT	VENTILATE	AD HEAT	AD VENTILATE	AD S+	HEAT S+	AUXILIARY HEATER UPGRADE	ROOM TEMPERATURE CONTROL S+ (water heater)	ADR MODE	ALB Automatic operating time calculation	START TIME	DEPARTURE TIME	TIMER PROGRAMMING	OPERATING TIME / TERMINAL 15	TEMPERATURE SENSOR	BUTTON	OPERATING TIME > 120 MINUTES	UNDERVOLTAGE DETECTION, CONTROL UNIT
HEAT	HEAT																	
VENTILATE	1	VENTILATE																
AD HEAT			AD HEAT															
AD VENTILATE				AD VENTILATE														
AD S+					AD S+													
HEAT S+						HEAT S+												
AUXILIARY HEATER UPGRADE							AUXILIARY HEATER UPGRADE											
ROOM TEMPERATURE CONTROL S+ (water heater)								ROOM TEMPERATURE CONTROL S+ (water heater)										
ADR MODE									ADR MODE									
ALB Automatic operating time calculation										ALB Automatic operating time calculation								
START TIME											START TIME							
DEPARTURE TIME												DEPARTURE TIME						
TIMER PROGRAMMING													TIMER PROGRAMMING					
OPERATING TIME / TERMINAL 15														OPERATING TIME / TERMINAL 15				
TEMPERATURE SENSOR															TEMPERATURE SENSOR			
BUTTON																BUTTON		
OPERATING TIME > 120 MINUTES																	OPERATING TIME > 120 MINUTES	
UNDERVOLTAGE DETECTION, CONTROL UNIT																		UNDERVOLTAGE DETECTION, CONTROL UNIT

1 Function is simultaneously visible in the menu, but cannot be executed simultaneously.  
5 only switching off is possible

#### PLEASE NOTE!

In the vehicle workshop menu, functions that are mutually exclusive are deactivated.

## 3 PRODUCT INFORMATION

### ALTITUDE KIT

Order No. 22 1000 33 22 01

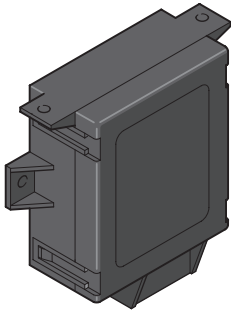

#### TECHNICAL DATA

Max. allowable altitude	approx. 4000 m asl
Measurement range	600 hPa to 1150 hPa
Rated voltage	12 volt / 24 volt
Operating voltage	8 – 32 volt
Dimensions	W: 76 mm, H: 76 mm, D: 29 mm
Operating temperature	– 40 °C to +85 °C
Installation location	Vehicle interior

#### INTENDED USE

The air pressure sensor, used in conjunction with the heater's control box, is for heating at high altitudes.

#### **PLEASE NOTE!**

For usability of the altitude kit, refer to the overview tables [on page 8](#).

For circuit diagrams see [from page 94](#).

## 4 INSTALLATION

### ALLOWABLE HEATER COMBINATIONS

With the EasyStart Timer and Remote+ control units a second heater can be controlled and operated using the AD menu item. For connection details see Timer [from page 30](#) and Remote+ circuit diagrams [from page 65](#)

The following list shows the allowable heater combinations.

#### 1ST HEATER

**Diagnostics cable connection** to the EasyStart control unit.

Hydronic – with automatic altitude adjustment function*
Hydronic II (Eco / E-Mobility / Comfort)
Hydronic II C (Commercial)
Hydronic M-II
Airtronic – with automatic altitude adjustment function*
Airtronic M – with automatic altitude adjustment function*
Airtronic L – with automatic altitude adjustment function*

#### COMBINABLE 2ND HEATER

**DAT cable connection** to the EasyStart control unit.

Hydronic – with automatic altitude adjustment function*
Hydronic II (Eco / E-Mobility / Comfort)
Hydronic II C (Commercial)
Hydronic M-II
Airtronic – with automatic altitude adjustment function*
Airtronic M – with automatic altitude adjustment function*
Airtronic L – with automatic altitude adjustment function*

#### 1ST HEATER

**Diagnostics cable connection** to the EasyStart control unit.

Hydronic – with automatic altitude adjustment function*
Hydronic II (Eco / E-Mobility / Comfort)
Hydronic II C (Commercial)
Hydronic M-II
Airtronic – with automatic altitude adjustment function*
Airtronic M – with automatic altitude adjustment function*
Airtronic L – with automatic altitude adjustment function*

#### COMBINABLE 2ND HEATER

**Control signal S+** connection to the EasyStart control unit.

Hydronic
Hydronic II (Eco / E-Mobility / Comfort)
Hydronic II C (Commercial)
Hydronic M-II
Hydronic L-II

\* from production in summer 2008 identifiably by “H-Kit” marked on the heater’s nameplate.



## 4 INSTALLATION

### OPTIONS

#### ADR MODE WITH EASYSTART TIMER

In this operating mode, ADR-conforming operation is enabled in combination with ADR-compatible heaters.

Programming of a timer is **NOT** permissible.

The control unit is informed whether an ADR case exists via the ADR-R input. If an active ADR case exists the heater is switched off.

A high level must be detected when the heater is activated, otherwise the heater is switched off again immediately.

#### ALTITUDE KIT – WITH ALL EASYSTART CONTROL UNITS

The altitude sensor, Order No.: 22 1000 33 22 00, can be used to operate the heater at high altitudes.

This also applies to the operation of two heaters.

#### TEMPERATURE DISPLAY – WITH EASYSTART TIMER, REMOTE+ AND SELECT

An external temperature sensor can be connected to the control unit for temperature display.

In the case of air heaters the internal temperature sensor is used primarily; however, if an external temperature sensor is connected to the control unit, it is always used.

#### PLEASE NOTE!

- The temperature used for room temperature control is displayed. The displayed temperature may differ from the real room temperature.
- Depending on the air heater's data set the measured temperatures of the control box / temperature sensor (programmed offset) may be displayed as being higher or lower.

#### TERMINAL 58 OR TERMINAL 15

The GYBK cable of the EasyStart Timer / Select can be optionally connected to terminal 58 or terminal 15. No PWM signal is allowed.

#### IMPORTANT INFORMATION FOR INSTALLATION OF THE EASYSTART CONTROL UNITS

#### PLEASE NOTE!

The control units must be protected with a maximum 5A fuse. The switching outputs may be loaded with 500 mA maximum.

### SPECIAL FUNCTIONS

#### EASYSTART TIMER / REMOTE+ – ROOM TEMPERATURE CONTROL FOR WATER HEATERS VIA VEHICLE FAN ACTIVATION

- Depending on the temperature measured by the temperature sensor, the vehicle fan is activated or deactivated via the switching output (S+ / VEH).
- Simultaneous operation of ALB (automatic operating time calculation) and room temperature control S+ is not appropriate for water heaters, as the setpoint value cannot be used twice. With immediate operation the room temperature control is active, in timer mode ALB is active.
- To prevent vibration of the vehicle fan it is necessary to set a hysteresis and sampling time > 0 (see vehicle workshop menu 12.2.2: and 12.2.3:).

#### EASYSTART TIMER / REMOTE+ / CALL – AUXILIARY HEATER UPGRADE

Two variants are possible for the auxiliary heater upgrade:

- Heaters **with** JE diagnostics
  - Use of the upgrade box mode
  - The vehicle fan and the water pump are controlled via a relay, which is activated when the auxiliary heater is started.

#### PLEASE NOTE!

Fan operation is **not** possible.

- Heaters **without** JE diagnosis (only Timer / Remote+)
  - Activate S+1 mode at the control unit.
  - The vehicle fan and the water pump are controlled via the additional upgrade box to be installed or via additional relays.

#### PLEASE NOTE!

It is **not** possible to diagnose the heater via the control unit.

#### EASYSTART TIMER / REMOTE+ – CONTROL OF THE FIRST HEATER VIA SWITCH-ON SIGNAL S+

The function must be activated via the workshop menu. Only the  symbol is visible in the display.

#### PLEASE NOTE!

- It is **not** possible to diagnose the heater via the control unit.
- In addition, the setpoint for air heaters must be set using a separate control unit.

## 4 INSTALLATION

### EASYSTART TIMER / REMOTE+ – CONTROL OF A SECOND HEATER

#### VARIANT 1

A second heater can be operated by using the DAT cable and the diagnostics cable.

However, an additional control unit **cannot** be connected.

Diagnosis of both heaters is possible.

#### VARIANT 2

By activating the switch output (S+ / VEH) it is possible to switch on any unit required.

A second control unit can be connected via the DAT cable.

Diagnosis of the 1st heater is possible, diagnosis of the 2nd heater is **not** possible.

### EASYSTART TIMER – OPERATING TIME DEPENDENT ON THE STATE OF TERMINAL 15

If the heater has been activated either via a timer or the buttons, the heater runs until the timer has expired or the terminal 15 signal fails (falling edge). It does not matter whether the terminal 15 signal was already applied or not when the heater was switched on.

If the heater is activated via the buttons and the operating time is then set to infinite (continuous operation) or the heater is activated via the buttons and the operating time was set to infinite, the heater responds to the terminal 15 signal as follows:

- If the terminal 15 signal fails to arrive the heater switches to a limited time mode, remaining operating time (adjustable).
- If a terminal 15 signal arrives within the remaining operating time the heater switches to continuous operation.

#### PLEASE NOTE!

The function is solely provided for air heaters. Continuous operation of water heaters is **not** possible.

### EASYSTART TIMER / SELECT – UNDERVOLTAGE DETECTION





This function can be used to detect an undervoltage and switch off the heater.

This undervoltage detection works independently of the heater's undervoltage detection.

#### PLEASE NOTE!

Depending on the parameterisation, both monitoring functions can become active simultaneously.

- The undervoltage detection of the control unit is only effective if a heater is active.

- The heater is switched off if the voltage  $U_{CU}$  at the control unit is below the threshold  $U_{OFF} + U_{\Delta}$  for longer than the debounce time. The undervoltage error display (Timer  / Select ) is shown until it is acknowledged for the timer with the  button and for Select with the .
- Boundary conditions for definition of the undervoltage threshold:
  - The measurement is taken not directly at the load (heater) but in the control unit.
  - The vehicle battery voltage depends on the applied load.
  - Due to the higher power consumption of the heater the voltage drop is higher for the heater
    - a higher voltage is measured at the control unit than at the heater.
- The threshold must be chosen so that the battery still has sufficient capacity for the subsequent actions (depending on the connected loads and temperatures).
- The effects of short-term disruptions, e.g. starting the motor, should not be taken into account → debounce time necessary.
- Determining the undervoltage threshold (circuit diagram [see page 99](#)):
  - The target lowest voltage at the battery at which heating mode is still allowed is  $U_{OFF}$ .
  - Voltage  $U_{CU}$  is measured at the control unit, which is value  $U_{\Delta}$  higher than the voltage at the heater
 
$$U_{HTR} - U_{CU} = U_{OFF} = U_{HTR} + U_{\Delta}$$
- The function is configured via point 3.1: ( $U_{OFF}$ ), 3.2: ( $U_{\Delta}$ ) and 3.3: (debounce time) of the workshop menu.

### EASYSTART TIMER / REMOTE+ – AUTOMATIC OPERATING TIME CALCULATION

The automatic operating time calculation is only allowed for water heaters and for operation of one heater. With other applications it is not possible to guarantee that the required interior temperature is reached.

## 4 INSTALLATION

### EASYSTART TIMER / REMOTE+ WORKSHOP MENU

The service functions listed in the following can be displayed, read out and / or changed via the vehicle workshop menu.

#### PLEASE NOTE!

- A reset (remove 5A fuse) is necessary to activate some functions. To do this, not and follow the relevant note under “Comments” of the “Service functions overview”.
- To correct the fault, refer to the heater’s repair instructions.

### OPENING THE VEHICLE WORKSHOP MENU

Display ON, the Start display appears.

Use the ◀ or ▶ button to select the  symbol in the Menu bar.

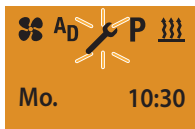

Confirm the SETTINGS menu item by pressing the  button.

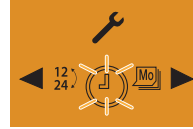

Press the  LONGPRESS button for longer than 5 sec.; the Workshop menu is displayed.





Press the ◀ or ▶ button to select the required function, e.g. »2: Select temperature unit, °C or °F◀ and confirm by pressing the  button.

Use the ◀ or ▶ button to select the temperature units °C or °F.





Press the  button to confirm the selection.

Press the  button to exit the workshop menu.

### SERVICE FUNCTIONS OVERVIEW

Menu item	Service function	Comments
1.1.1:	Heater 1 – display current fault	The heater must be switched on to detect current faults. “no diag” is displayed if no diagnostics cable is connected.
1.1.2:	Heater 2 – display current fault	The heater must be switched on to detect current faults. “no diag” is displayed if no diagnostics cable is connected.
1.2.1:	Heater 1 – read out fault memory F1 – F5	Display fault memory F1 – F5 with error code, e.g.: F1: 12. “no diag” is displayed if no diagnostics cable is connected.
1.2.2:	Heater 2 – read out fault memory F1 – F5	Display fault memory F1 – F5 with error code, e.g.: F1: 12. “no diag” is displayed if no diagnostics cable is connected.
1.3.1:	Heater 1 – delete fault memory F1 – F5	Select the delete → function by pressing the  button, the DEL display appears, flashing, press the  button to confirm. “no diag” is displayed if no diagnostics cable is connected.
1.3.2:	Heater 2 – delete fault memory F1 – F5	Select the delete → function by pressing the  button, the DEL display appears, flashing, press the  button to confirm. “no diag” is displayed if no diagnostics cable is connected.
1.4.1:	Heater 1 – read out operating hours counter	Operating time is displayed in minutes. “no diag” is displayed if no diagnostics cable is connected.
1.4.2:	Heater 2 – read out operating hours counter	Operating time is displayed in minutes. “no diag” is displayed if no diagnostics cable is connected.

## 4 INSTALLATION

Menu item	Service function	Comments
2:	Select temperature unit, °C or °F	Default: °C
3.1:	Set the undervoltage limit (EasyStart Timer only)	Default: 8 volt, Setting range: 8 – 28 volt in 0.1 volt increments.
3.2:	Set the undervoltage limit “offset” (EasyStart Timer only)	Default: 0 volt, Setting range: 0 – 6 volt in 0.1 volt increments.
3.3:	Set the “fault detection” debounce time (EasyStart Timer only)	Default: 20 seconds, Setting range: 5 – 255 seconds in 1 second increments.
4.1:	Heater 1 – set max. operating time (EasyStart Timer only)	Default: 120 min. Setting range: 10 – 120 min. in 1 min. increments, from the 120th min. – 720 min. in 5 min. increments. Continuous heating mode is also possible for air heaters. These settings have no effect on the operating time for timer programming.
4.2:	Heater 2 – set operating time (EasyStart Timer only)	Default: 120 min. Setting range: 10 – 120 min. in 1 min. increments, from the 120th min. – 720 min. in 5 min. increments. Continuous heating mode is also possible for air heaters. These settings have no effect on the operating time for timer programming.
5:	Reset to as delivered condition	Press the  button to select the function, the default display appears, flashing, press the  button to confirm. All active timers are deleted.
6.1:	Read out control unit hardware version	Function is intended for internal purposes only.
6.2:	Read out control unit software version	Function is intended for internal purposes only.
7:	Check measurement of the range (EasyStart Remote+ only)	Take a check measurement. Stand with the mobile unit at a distance of 1 m in front of the vehicle and in the workshop menu, press the  or  button to select item 7: If a value between 75 and 100 is displayed for R and S the measurement is ok. Note on the check measurement: With an optimum installation the transmission power can reach a maximum value of 100. If the maximum value is not reached, change the location of the antenna so that a value for R and S is reached between the minimum value 75 and the maximum value 100.
8:	Select language, DE or EN	Default: EN
9:	Set upgrade box mode, On or Off	Default: Off A reset must be performed to activate the function (remove fuse).
10:	Select start time (On) or departure time (Off)	Default: Off (departure time) The departure time (Off) is absolutely necessary for heating mode with automatic operating time calculation (Item 11.1.). For heating mode without automatic operating time calculation (item 11.1.) it is possible to choose between start time (On) and departure time (Off). A reset must be performed to activate the function (remove fuse).

## 4 INSTALLATION

Menu item	Service function	Comments
11.1:	Set automatic operating time calculation, On or Off	Default: Off A temperature sensor must be connected to the control unit or stationary unit. Additional settings are required, see Item 11.2: and 11.3: A reset must be performed to activate the function (remove fuse). Automatic operating time calculation is not possible for air heaters.
11.2:	Set the engine size (cubic capacity)	Default: 1800 cm <sup>3</sup> Setting range: 1000 cm <sup>3</sup> – 4000 cm <sup>3</sup> in 100 cm <sup>3</sup> increments. The engine size can only be set if 11.1: is set to On.
11.3:	Set the max. operating time	Default: 60 min, Setting range: 10 min. – 60 min. in 1 min. increments. The max. operating time can only be set if 11.1: is set to On.
12.1:	Set add-on unit AD, On or Off	Default: Off Selection options: 1. Via JE diagnosis → display flame and ventilate symbol (if supported by the heater) in the AD menu. 2. Via switch-on signal S+2 (deactivated 1.2.2:, 1.3.2:, 1.4.2:, 9:) → S+2 (display only flame symbol and AD heat menu visible). 3. Via the switch-on signal of the first heater S+1 (deactivated 1:) → S+1 (display heat menu only). A reset must be performed to activate the function (remove fuse).
12.2.1:	Room temperature control, On or Off	Default: Off
12.2.2:	Hysteresis (On / Off difference): 0 – 7 °C	Default: 2 °C
12.2.3:	Sampling rate: 0 – 15 seconds	Default: 5 seconds
13.1:	Select KL58 or KL15 mode	Default: KL58. Input KL58 = control background lighting of control unit. A reset must be performed to activate the function (remove fuse).
13.2:	If KL15 mode is active	Default setting: 15 min. Set afterrun time of heater until shutdown. Setting range: 1 – 255 min Value 0 = heater always remains in continuous operation.
14.1:	Show display pixels	Check the individual pixels in test mode. If there are too many defective pixels, replace the control unit if necessary.
14.2:	Show display pixels	Check the individual pixels in test mode. If there are too many defective pixels, replace the control unit if necessary.
14.3:	Show display pixels	Check the individual pixels in test mode. If there are too many defective pixels, replace the control unit if necessary.
14.4:	Show display pixels	Check the individual pixels in test mode. If there are too many defective pixels, replace the control unit if necessary.
14.5:	Show display pixels	Check the individual pixels in test mode. If there are too many defective pixels, replace the control unit if necessary.

## 4 INSTALLATION

Menu item	Service function	Comments
14.6:	Show display contrast	<p>This function can be used to change the contrast of the display.</p> <p><b>PLEASE NOTE!</b></p> <p>It is also possible to reduce the contrast to such an extent that the screen display is no longer visible. With each PowerOnReset (remove fuse) the contrast is reset to the as-delivered condition.</p>

### EASYSTART SELECT VEHICLE WORKSHOP MENU

The service functions listed in the following can be displayed, read out and / or changed via the vehicle workshop menu.

**PLEASE NOTE!**

To correct the fault, refer to the heater's repair instructions.



### OPENING THE VEHICLE WORKSHOP MENU

Display ON, the Start display appears.



Start display  
water heater



Start display  
air heater

Press button and at the same time for longer than 5 sec.

The workshop menu is displayed.

Press the or button to select the required item, e.g. »Item 2:  
Select temperature unit, °C or °F« and confirm by pressing the button.

Use the or button to select the temperature units °C or °F.





Press the button to confirm the selection.

Exit the workshop menu via Timeout.

### SERVICE FUNCTIONS OVERVIEW

Menu item	Service function	Comments
1.1:	Display current fault	<p>Heater must be switched on.</p> <p>The AF display and the digits of the current fault are displayed alternately.</p> <p>The current fault is always written in fault memory F1.</p> <p>“ndi” is displayed if no diagnostics cable is connected.</p>
1.2:	Read out fault memory F1 – F5	<p>Heater must be switched on.</p> <p>The F1 display and the digits of the error code are displayed alternately.</p> <p>Select fault memory F2 – F5 display with the  or  button.</p> <p>“ndi” is displayed if no diagnostics cable is connected.</p>

## 4 INSTALLATION

Menu item	Service function	Comments
1.3:	Delete fault memory F1 – F5	Heater must be switched on. Press the  button to confirm the DEL display. “ndi” is displayed if no diagnostics cable is connected.
2:	Select temperature unit, °C or °F	Default: °C
3.1:	Set undervoltage limit	Default: 8 volt, Setting range: 8 – 28 volt in 0.1 volt increments (display, e.g. 271 for 27.1 volt).
3.2:	Set undervoltage limit “Offset”	Default: 0 volt, Setting range: 0 – 6 volt in 0.1 volt increments (display, e.g. 55 for 5.5 volt).
3.3:	Set “Fault detection” debounce time	Default: 20 seconds, Setting range: 5 – 255 seconds in 1 second increments.
4.1:	Setting the operating time	Default: 60 min. for water heaters / infinite for air heaters Setting range: 10 – 120 min. in 1 min. increments, from the 120th min. – 720 min. in 5 min. increments.  Continuous heating mode is also possible for air heaters (select OFF).   <b>PLEASE NOTE!</b> The function is blocked for combination with other control units.
5:	Reset to as delivered condition	Press → button  to confirm.
6.1:	Read out control unit hardware version	Function is intended for internal purposes only.
6.2:	Read out control unit hardware version	Function is intended for internal purposes only.
6.3:	Read out control unit software version	Function is intended for internal purposes only.
6.4:	Read out control unit software version	Function is intended for internal purposes only.
14:	Show all icons (display)	Cancel with  button

## 4 INSTALLATION

### EASYSTART CALL – DIAGNOSIS

The EasyStart Call has a diagnostic function. If errors occur, they are stored and can be read out as needed with the EDiTH Basic diagnostic tool in conjunction with the EDiTH software (version S4V1-F or higher). The adapter cable (Order No.: 22 1000 34 11 00) is also required.

#### PERFORM THE DIAGNOSIS

Separate the EasyStart Call / heater cable loom interface, connect the EDiTH Basic diagnostic tool with the adapter cable and start the diagnosis.

#### THE FOLLOWING ACTIONS ARE POSSIBLE:

- Read out the current error and the error memory for the EasyStart Call and for the heater.
- Delete the error memory for the EasyStart Call and for the heater.
- Query software version.
- Query hardware version.
- Query the operating hours of the heater.
- Carry out, read out and change the configuration of the EasyStart Call.
- Revert to factory settings for the EasyStart Call.

#### PLEASE NOTE!

The error memory can only be read out with the EDiTH diagnostic tool (version S4V1-F or higher).

Error code	Error description	Remedial action
0	No fault	---
1	SIM card holder not found	Remove and install SIM card holder with SIM card. Ensure that you install the SIM card holder properly. Use original JE SIM card holders only.
2	Incorrect SIM PIN code	Deactivate the PIN query on the SIM card; if not possible change SIM PIN to 1865 or use the EDiTH diagnostics tool to change the PIN of the EasyStart Call to the same number as the SIM PIN of the SIM card.
3	PUK entry required	Enter the PUK via mobile phone and then deactivate the PIN query; if not possible change SIM PIN to 1865 or change the PIN of the EasyStart Call with the EDiTH diagnostic tool to the SIM PIN of the SIM card.
4	No network	SIM card not valid or not activated (provider). Check antenna.
5	No GSM network time	The provider does not support the function "Automatic time"; enter the day of the week and the time by hand.
6, 7, 8, 11	Internal error	EasyStart Call defective → replace unit
9	Unable to send text message	SIM card not valid or not activated (provider). If you are using a prepaid card, check the balance, if necessary load your prepaid card.
10	SIM card holder inserted, but no connection with the SIM card	No SIM card in the SIM card holder → insert SIM card. SIM card is defective → replace SIM card.



## 4 INSTALLATION

### EASYSTART CALL – APP MANUAL

#### INITIAL STARTUP

##### Configure EasyStart Call

- **Four-digit security PIN**  
Touch the “Four-digit security PIN” button and enter the PIN (password) of your EasyStart Call. The PIN (password) is set in the factory to “1234”.
- **Heater phone number**  
You were issued with a phone number by your network operator when you purchased the SIM card. This is the phone number of your EasyStart Call.  
Touch the “Heater phone number” button and enter the phone number of the EasyStart Call.  
Your phone number must be entered with the + symbol or 00 in the country dialling code (e.g. +49 or 0049 for Germany).
- **Unit name (optional)**  
For simplified selection, e.g. when using several heaters, it is advisable to assign a name to each heater.  
Touch the “Unit name (optional)” button and enter a name for the unit.
- **Confirm entries**  
Touch the “Finished” button to confirm your entries.  
After confirming two SMS messages are sent to the EasyStart Call for configuration.

#### PLEASE NOTE!

The App is adjusted to the relevant functions of the heater by means of feedback from the EasyStart Call. The “Heater feedback” is read out automatically.

- **Time**  
The time of your smartphone is sent to the heater. No further settings are necessary if your smartphone and the heater are in the same time zone.

#### BASIC SETTINGS OF THE APP

(“Info and Options” menu bar)

- **App manual**  
Touch the “App manual” button to display the App manual.
- **Intro**  
Here you can touch the button to switch on or off the Eberspächer Intro, which is run when the App is started.
- **SMS warnings and alerts**  
Touch the “SMS alerts” button to activate or deactivate and press the “OK” button to confirm.

#### PLEASE NOTE!

Each time before an SMS is sent you are warned that this will incur a charge. If you deactivate the SMS warnings you are no longer informed about these charges.

It is recommended that you do not deactivate the SMS warning until you are completely familiar with use of the App.

- **Weather alert**  
Touch the “Weather alert” button to activate or deactivate it  
Activate weather alert:  
Enter the location of your vehicle next to the “Enter place” field and choose the place from the field below it. Then press the “Finished” button.  
Then use the scroll wheel to select a threshold temperature, below which the App should remind you to heat your vehicle.  
If the weather forecast announces a temperature lower than the temperature set, you are notified the evening before by an alert.  
You must agree to the conditions of use, in order to use the weather alert.

#### PLEASE NOTE!

The weather alert requires an internet connection, which can cause costs.

When setting up the weather alert you receive a registration message. The weather alert is not set successfully until after you have received this message. The “Weather alert” button should be green after the function has been set up successfully.

- **Change language**  
If you touch the “Change language” button a dropdown menu opens. Now choose the required language by touching it and then press the “Finished” button. The App then restarts and the new language is set.

#### HEAT / VENTILATE

- **Immediate operation**  
If several vehicles are assigned and are divided between the two pools, select the required pool first.  
Then select the duration (“Minutes” scroll wheel) and the “Mode” (heat / ventilate) for one or several required heaters.

## 4 INSTALLATION

Then touch the “Start” button, all assigned heaters are displayed in the next screen.

- **Green tick:**  
Settings have already been made and the heater is started.
- **Red cross:**  
Settings have not been made. If the heater is to be started with the stored settings, touch the image to set the green tick. Touch the “Now send” button and one or several SMS messages are sent to the heaters with green ticks. These heaters start immediately after the SMS transmission. If the heater is “ON” the scroll wheel shows the minutes of the remaining operating time in red.

### PLEASE NOTE!

- You can select a value between 10 and 120 minutes or “∞” for continuous operation.
- Continuous operation is only possible for air heaters.
- Settings can also be made while the heater is running.
- Query status (“Mode” scroll wheel)

Turn the “Mode” scroll wheel of the required heater to “Status”. Then touch the “Start” button, the images of all assigned heaters are displayed in the next screen. The heater whose status is to be queried is displayed with a green tick. Touch the “Now send” button and one or several SMS messages are sent to the heater or heaters with green ticks. The status of these heaters is sent by return SMS, which must be copied into the App if you are using the Apple operating system (see above). No function in Android operating systems. Further settings (by pressing the “Gearwheel” symbol at the respective heater)

- **Insert photo (optional)**  
Touch the button with the Eberspächer logo, to assign a photo from your smartphone memory to your unit.
- **Entering the setpoint (for air heater only)**  
Use the scroll wheel to select a temperature from the temperature range 8 °C – 36 °C / 46 °F – 97 °F.
- **Query status**  
Touch the “Query status” button. You then receive a reply by SMS from your EasyStart Call with the current settings, which must be copied into the App. The current status is displayed in the “Last status” field.

- **Actual value display**  
The current value display shows the current temperature in the vehicle. This is transmitted by the temperature sensor connected in the vehicle interior. Unlike the setpoint value, the actual value display cannot be changed.
- **Programming the timer**  
Before you carry out the timer programming you can change the timer reference in the “Vehicle settings” menu:
- **Timer reference (departure time / start time)**  
Note: The start time for the heater is set in the factory to departure time. You can select your departure time (when would you like to leave?) or the starting time for the heater as the timer reference. If you choose the departure time, e.g. for a required heating period of 30 min., the heater calculates this time backwards and accordingly starts half an hour earlier. In the vehicle settings menu you can choose between departure and start time.

You can make three different timer settings. To do this, touch the required button: “Timer 1”, “Timer 2” or “Timer 3”. You are then switched to the next screen where you can make detailed timer settings.

Confirm your entries by touching the “Finished” button, or touch the “Cancel” button to exit the process.

### PLEASE NOTE!

The weekday can be selected individually or as a weekday group MO – FR, SA – SU or MO – SU. Only one weekday group can be selected.

Continuous operation is not possible for setting via the timer.

- **Activate timer**
  - Touch the required button under the “Timer 1”, “Timer 2” or “Timer 3” field.
  - If the respective timer has not yet been set you are switched to the next screen where you can make the required settings and confirm with “Finished”. An SMS with the timer settings is now sent to the heater. The button colour changes from red (not activated) to green (activated),
  - If the respective timer is already stored (e.g. for an already used timer), an SMS is sent to the heater immediately to activate the timer. The button changes from red to green.

## 4 INSTALLATION

### PLEASE NOTE!

If the timer event has already taken place the timer must be reactivated. This is necessary at the latest after the longest possible time period of 7 days.

- **Timer status (Timer submenu)**  
Touch the “Timer status” button and you receive an SMS reply from your heater with the current settings of all timers.
- **Delete unit**  
Here you can remove an assigned heater. Touch the “Delete unit” button, the currently displayed unit is then deleted.
- **Vehicle settings**  
Touch the “Vehicle setting” button and the display switches to the basic settings menu (see next section).

### BASIC SETTINGS

- **Changing the time**  
Adjust the time of the EasyStart Call and the smartphone (not necessary if your vehicle is in a different time zone to your smartphone) In this case, touch the “Change time” button. Use the “Time difference” scroll wheel to select the number of hours equal to the time difference and confirm for your EasyStart Call with the “Finished” button.
- **Changing the PIN**  
Touch the “Change PIN” button and enter the new four-digit PIN. Allowable range 0000–9999. The PIN is set in the factory to “1234”. Please note: The four-digit PIN is not the SIM PIN!
- **Changing the phone number of the control**  
Touch the “Change control's phone number” button and enter the new phone number.  
Your phone number must be entered with the + symbol or 00 in the country dialling code (e.g. +49 or 0049 Germany).
- **Timer reference (see explanation under Timer Programming section)**  
Choose between the departure time and the start time by touching one of the two buttons.
- **Temperature unit**  
Select Celsius or Fahrenheit as the temperature unit by touching one of the two buttons. The factory setting here is Celsius.
- **Error message (heater)**  
Touch the button to activate or deactivate the “Error message” by SMS function.
- **Heater feedback**  
Touch the button to activate or deactivate the “Heater feedback” by SMS function. “Heater feedback” is deactivated in the factory settings.

### TASKBAR

- **“Gearwheel / Info and Options” symbol**  
Touch the “Gearwheel / Info and Options” symbol to switch to the “Basic App settings” menu.
- **“+ symbol / Add unit”**  
Touch the “+ symbol / Add unit”. You can now assign and manage up to 5 heaters each in two pools.
- **“! symbol / Current information”**  
Touch the “! / Current Information” symbol and you will be shown current information about Eberspächer Climate Control Systems GmbH & Co. KG.
- **“§ / T&Cs Imprint” symbol**  
Touch the “§ / T&Cs Imprint” symbol and you will be shown information about Eberspächer Climate Control Systems GmbH & Co. KG's general terms and conditions of business.

### NOTES

- A phone number may only be stored once in the EasyStart Call. If a phone number is stored more than once proper functioning of the EasyStart Call cannot be guaranteed.
- Costs (phone charges) are incurred when you make a call, send an SMS and receive “Heater feedback” or an “Error message” by SMS.
- If “Heater feedback” has been activated an SMS is returned by the heater as confirmation.
- If an SMS contains a status query (e.g. heater?), an SMS is always sent back, even if “Heater feedback” is deactivated.
- The “Heater Feedback” and “Error Message” functions are deactivated in the factory settings.
- Each time before an SMS is sent a warning is displayed reminding you that this will incur a charge. The warning can be deactivated. However, you should not do this unless you are completely familiar with use of the App.
- If the heater is used abroad, additional costs (roaming charges) are incurred.

## 4 INSTALLATION

- If the EasyStart Call is used in the border area with a neighbouring country, roaming charges can also be incurred due to overlapping network coverage.
- Note the location of your vehicle with respect to the call setup. Buildings or other obstructions can prevent mobile phone signals.
- Due to the running times of the provider and / or dead spots an SMS can be delivered late.
- To prevent excessive discharge of the vehicle battery in preselected heating mode and on short trips, we recommend you set the heating time according to the trip time.  
Example: For a trip time of approx. 30 minutes (single distance), the heating time should be set to 30 minutes maximum.
- The “ventilate” function is not supported by all heater versions.
- The heating time in immediate operation is factory set to 30 minutes for water heaters and to continuous operation for air heaters.
- The heating and ventilation time can be changed; you can select a period between 10 and 120 minutes.
- Continuous operation is only available for air heaters in immediate operation.
- Continuous operation is not possible in preselected heating mode.
- You can be notified by SMS (error message) if faults or errors occur in the heater or EasyStart Call (“error message” must be activated).
- The SMS message is sent to the sender of the last SMS to be sent (“Heater feedback” must be activated).
- To display the interior temperature, the room temperature sensor must be connected.
- Temperature preselection (setpoint) is only possible for air heaters.

Further information is given in the operating instructions of the EasyStart Call. Internet: [www.eberspaecher-standheizung.com](http://www.eberspaecher-standheizung.com)

We cannot always detect changes made to the Android operating system by providers and therefore we cannot guarantee compatibility with your smartphone.

## 4 INSTALLATION

### ALTITUDE KIT – DIAGNOSIS

The air pressure sensor connected to the heater can be diagnosed. If errors occur during the altitude adjustment they are saved in the air pressure sensor and can be read out if necessary using the ISO adapter in conjunction with the EDiTH customer service program – Version S3V7-F and higher.

The adapter cable (Order No.: 22 1000 33 31 00) is also required.

#### PERFORM DIAGNOSIS OF THE AIR PRESSURE SENSOR

Disconnect the air pressure sensor / heater cable loom interface, connect the ISO adapter with the additionally required adapter cable and start the diagnosis of the air pressure sensor.

#### THE FOLLOWING ACTIONS ARE POSSIBLE:

- Read out the current fault and the fault memory.
- Delete the fault memory.
- Query the current measured air pressure.
- Query the operating state.
- Query the general data.

### PLEASE NOTE!

The fault memory of the air pressure sensor can only be read out with the EDiTH customer service program – Version S3V7-F and higher.

The heater diagnosis can be performed even if the air pressure sensor is connected

- with the EasyStart Timer, EasyStart Remote+, EasyStart Select, EasyStart Call control units.
- with the diagnostic unit or EDiTH Basic; the connection to the “Heater connection plug / cable harness” interface is made with a corresponding adapter cable.

Error code	Error description	Remedial action
<b>Air pressure sensor</b>		
0	No fault	---
11	Communication loss on the diagnostics cable between the HCTRL and air pressure sensor	Interruption on the diagnostics cable between the heater control unit HCTRL and air pressure sensor → check the wiring and plug-in connections
12	HCTRL does not support altitude mode with the air pressure sensor	The air pressure sensor has been connected to a heater that does not support altitude adjustment → use of a heater that supports altitude adjustment
13	Air pressure sensor fault	The air pressure sensor is defective → replace the air pressure sensor

## 5 CIRCUIT DIAGRAM

### OVERVIEW OF THE CIRCUIT DIAGRAMS

#### EASYSTART TIMER

TIMER →	1 HEATER	
	Hydronic, Hydronic II, Hydronic II C, Hydronic II Comfort, Hydronic M II	32
	Airtronic, Airtronic M, Airtronic L	33
TIMER WITH BUTTON →	1 HEATER	
	Hydronic, Hydronic II, Hydronic II C, Hydronic II Comfort, Hydronic M	34
	Hydronic, Hydronic II, Hydronic II C, Hydronic II Comfort, Hydronic M II, Hydronic L II	35
	Hydronic auxiliary heater	36
	Hydronic auxiliary heater with upgrade box	37
	Airtronic, Airtronic M, Airtronic L with external control temperature sensor, interior, e.g. for fresh air mode	38
TIMER →	2 HEATERS	
	Hydronic, Hydronic II, Hydronic II C, Hydronic II Comfort, Hydronic M II (diagnostics cable)	
	<b>AND</b> Hydronic, Hydronic II, Hydronic II C, Hydronic II Comfort, Hydronic M II (diagnostics cable)	39
	Hydronic, Hydronic II, Hydronic II C, Hydronic II Comfort, Hydronic M II (diagnostics cable)	
	<b>AND</b> Hydronic, Hydronic II, Hydronic II C, Hydronic II Comfort, Hydronic M II, Hydronic L II (switch-on signal S+)	40
	Hydronic, Hydronic II, Hydronic II C, Hydronic II Comfort, Hydronic M II (diagnostics cable)	
	<b>AND</b> Airtronic, Airtronic M, Airtronic L (diagnostics cable)	41
	Airtronic, Airtronic M, Airtronic L (diagnostics cable)	
	<b>AND</b> Airtronic, Airtronic M, Airtronic L (diagnostics cable)	42
TIMER WITH BUTTON →	2 HEATERS	
	Airtronic, Airtronic M, Airtronic L and Hydronic, Hydronic II, Hydronic II C (diagnostics cable)	
	<b>AND</b> Hydronic II Comfort, Hydronic M II, Hydronic L II (switch-on signal S+)	43
COMBINED CONTROL UNITS		
TIMER / TIMER →	1 HEATER	
	Hydronic, Hydronic II, Hydronic II C, Hydronic II Comfort, Hydronic M II	44
	Hydronic, Hydronic II, Hydronic II C, Hydronic II Comfort, Hydronic M II, Hydronic L II	45
	Airtronic, Airtronic M, Airtronic L	46
TIMER / REMOTE →	1 HEATER	
	Hydronic, Hydronic II, Hydronic II C, Hydronic II Comfort, Hydronic M II	47
	Airtronic, Airtronic M, Airtronic L	48
	Hydronic, Hydronic II, Hydronic II C, Hydronic II Comfort, Hydronic M II, Hydronic, L II via switch-on signal S+	49
TIMER / SELECT →	1 HEATER	
	Hydronic, Hydronic II, Hydronic II C, Hydronic II Comfort, Hydronic M II	50
	Airtronic, Airtronic M, Airtronic L	51
	Hydronic, Hydronic II, Hydronic II C, Hydronic II Comfort, Hydronic M II, Hydronic, L II via switch-on signal S+	52

## 5 CIRCUIT DIAGRAM

### COMBINED CONTROL UNITS

TIMER / TIMER →	2 HEATERS	
	1st heater: Hydronic, Hydronic II, Hydronic II C, Hydronic II Comfort, Hydronic M II via diagnostics cable <b>AND</b> 2nd heater via switch-on signal S+	<a href="#">53</a>
	1st heater: Airtronic, Airtronic M, Airtronic L via diagnostics cable <b>AND</b> 2nd heater via switch-on signal S+	<a href="#">54</a>

### SPECIAL FUNCTIONS

TIMER →	1 HEATER WITH ROOM TEMPERATURE CONTROLLER	
	Hydronic, Hydronic II, Hydronic II C, Hydronic II Comfort, Hydronic M II	<a href="#">55</a>

### ADR MODE

TIMER WITH BUTTON →	1 HEATER	
	Hydronic II C, Hydronic M II	<a href="#">56</a>
	Hydronic 24 volt, Hydronic II C, Hydronic M II via switch-on signal S+	<a href="#">57</a>
	Airtronic, Airtronic M, Airtronic L	<a href="#">58</a>

### ADR MODE WITH COMBINED CONTROL UNITS

TIMER / TIMER →	1 HEATER	
	Hydronic 24 volt, Hydronic II C, Hydronic M II via switch-on signal S+	<a href="#">59</a>
	Hydronic II C, Hydronic M II	<a href="#">60</a>
	Airtronic, Airtronic M, Airtronic L	<a href="#">61</a>
TIMER / SELECT →	1 HEATER	
	Hydronic 24 volt, Hydronic II C, Hydronic M II via switch-on signal S+	<a href="#">62</a>
	Hydronic II C, Hydronic M II	<a href="#">63</a>
	Airtronic, Airtronic M, Airtronic L	<a href="#">64</a>

### PLEASE NOTE!

Optional components and cables are shown with dashed lines in the circuit diagrams.

The “Interior temperature sensor -B8” is included with the EasyStart Remote+ and EasyStart Call.

For the EasyStart Timer the “Interior temperature sensor -B8” must be ordered separately (Order No. 22 1000 34 22 00).

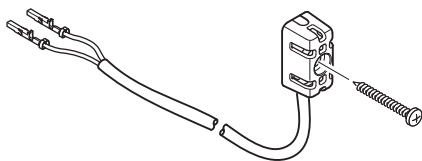

The “External control temperature sensor, interior -B9” must be ordered separately (Order No. 25 1774 89 03 00).

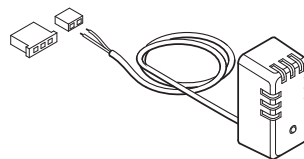

## 5 CIRCUIT DIAGRAM

### EASystART TIMER CONNECTION

Hydronic, Hydronic II, Hydronic II C, Hydronic II Comfort, Hydronic M II

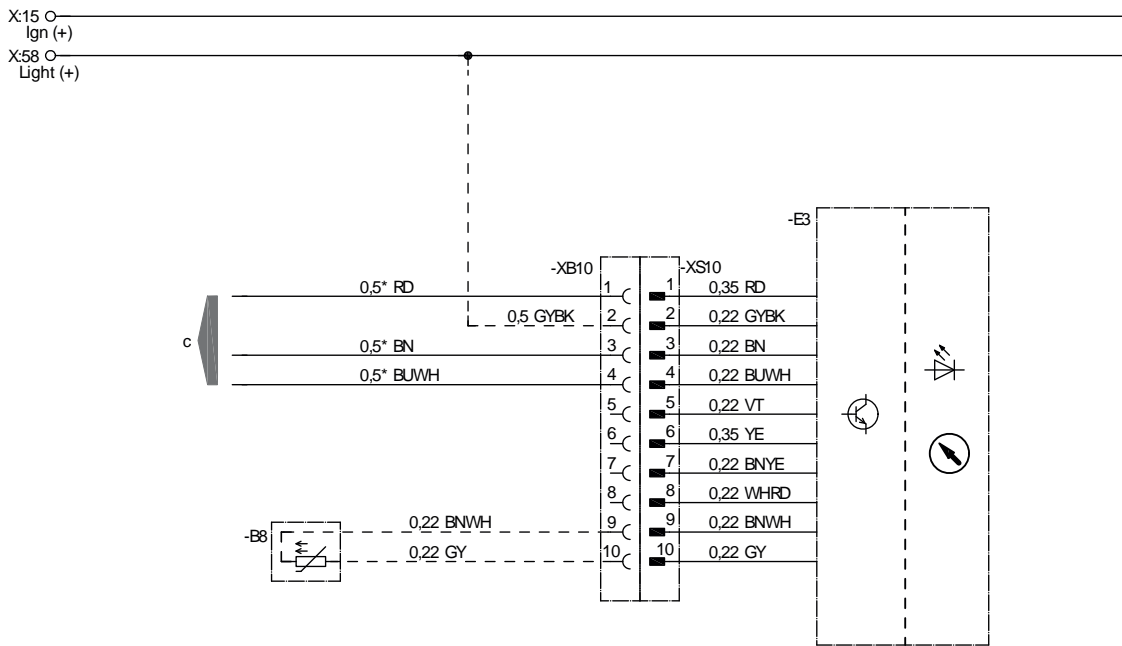

\* Hydronic MII 0,75

22 1000 34 97 01

- B8 Sensor, interior temperature
- E3 EasyStart Timer
- c to the heater

#### CABLE COLOURS

RD	red	GY	grey	BK	black
BU	blue	YE	yellow	GN	green
WH	white	VT	violet	BN	brown



## 5 CIRCUIT DIAGRAM

### EASYSTART TIMER CONNECTION

Airtronic, Airtronic M, Airtronic L

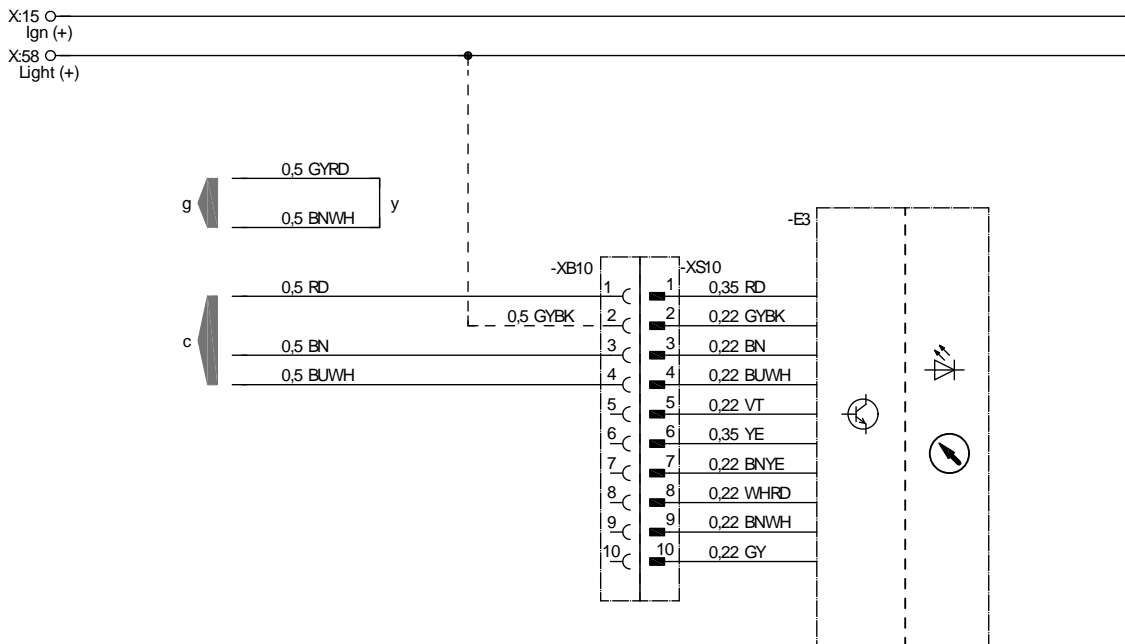

22 1000 34 97 02

- E3 EasyStart Timer
- c to the heater
- g to the heater
- y Connect cables and insulate

#### CABLE COLOURS

RD	red	GY	grey	BK	black
BU	blue	YE	yellow	GN	green
WH	white	VT	violet	BN	brown

## 5 CIRCUIT DIAGRAM

### EASYSTART TIMER WITH BUTTON CONNECTION

Hydronic, Hydronic II, Hydronic II C, Hydronic II Comfort, Hydronic M II

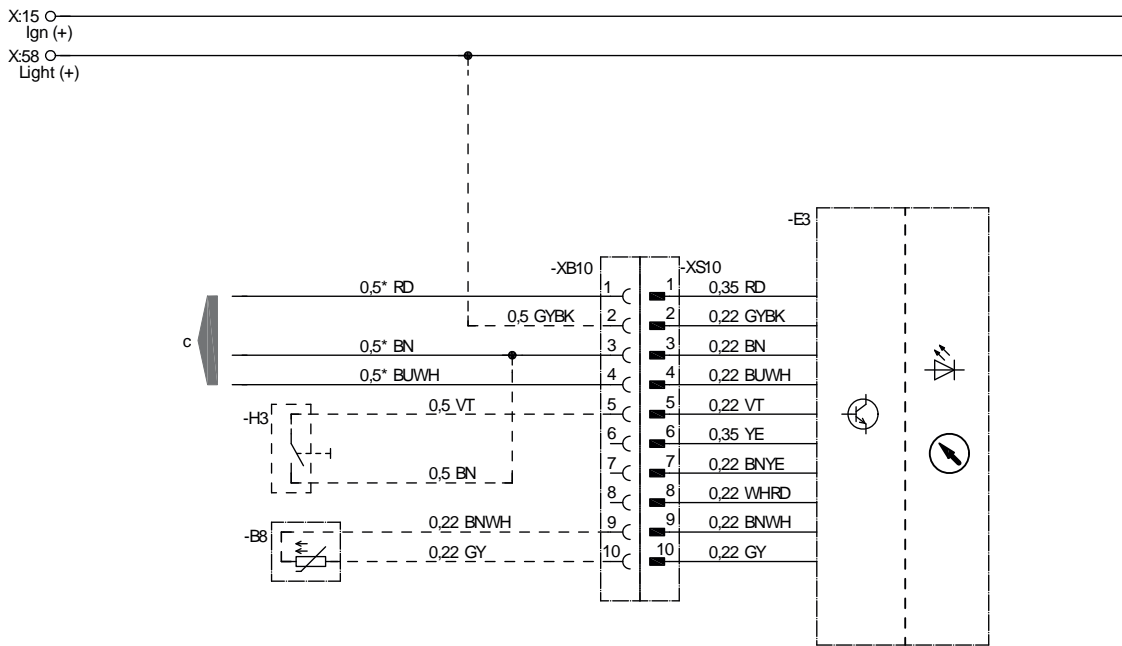

\* Hydronic MII 0.75

22 1000 34 97 11

- B8 Sensor, interior temperature
- E3 EasyStart Timer
- H3 EasyStart Timer button
- c to the heater

#### CABLE COLOURS

RD	red	GY	grey	BK	black
BU	blue	YE	yellow	GN	green
WH	white	VT	violet	BN	brown

## 5 CIRCUIT DIAGRAM

### EASYSTART TIMER WITH BUTTON CONNECTION VIA SWITCH-ON SIGNAL S+

Hydronic, Hydronic II, Hydronic II C, Hydronic II Comfort, Hydronic M II, Hydronic L II

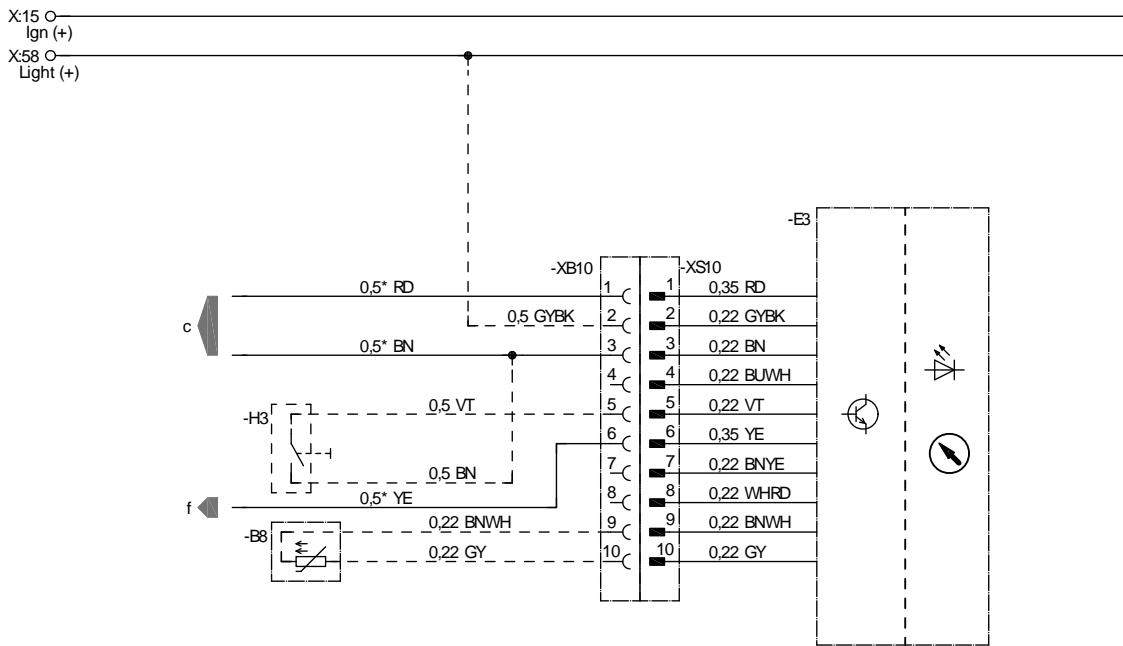

\* Hydronic MII 0,75 / Hydronic L 1,0

22 1000 34 97 03

- B8 Sensor, interior temperature
- E3 EasyStart Timer
- H3 EasyStart Timer button
- c to the heater
- f Switch-on signal S+

#### CABLE COLOURS

RD	red	GY	grey	BK	black
BU	blue	YE	yellow	GN	green
WH	white	VT	violet	BN	brown

## 5 CIRCUIT DIAGRAM

### EASYSTART TIMER WITH BUTTON CONNECTION

Hydronic auxiliary heater

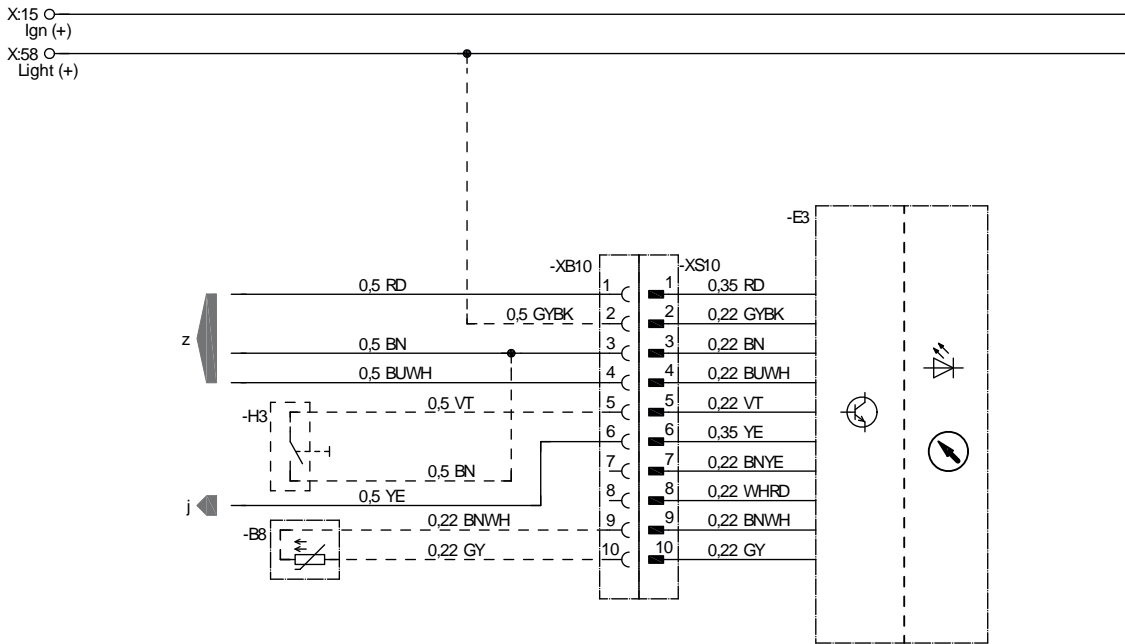

22 1000 34 97 45

- B8 Sensor, interior temperature
- E3 EasyStart Timer
- H3 EasyStart Timer button
- z to the auxiliary heater
- j to the relay for connection of water pump and vehicle fan (max. 500 mA)

#### CABLE COLOURS

RD	red	GY	grey	BK	black
BU	blue	YE	yellow	GN	green
WH	white	VT	violet	BN	brown

## 5 CIRCUIT DIAGRAM

### EASYSTART TIMER WITH BUTTON CONNECTION

Hydronic auxiliary heater with upgrade box

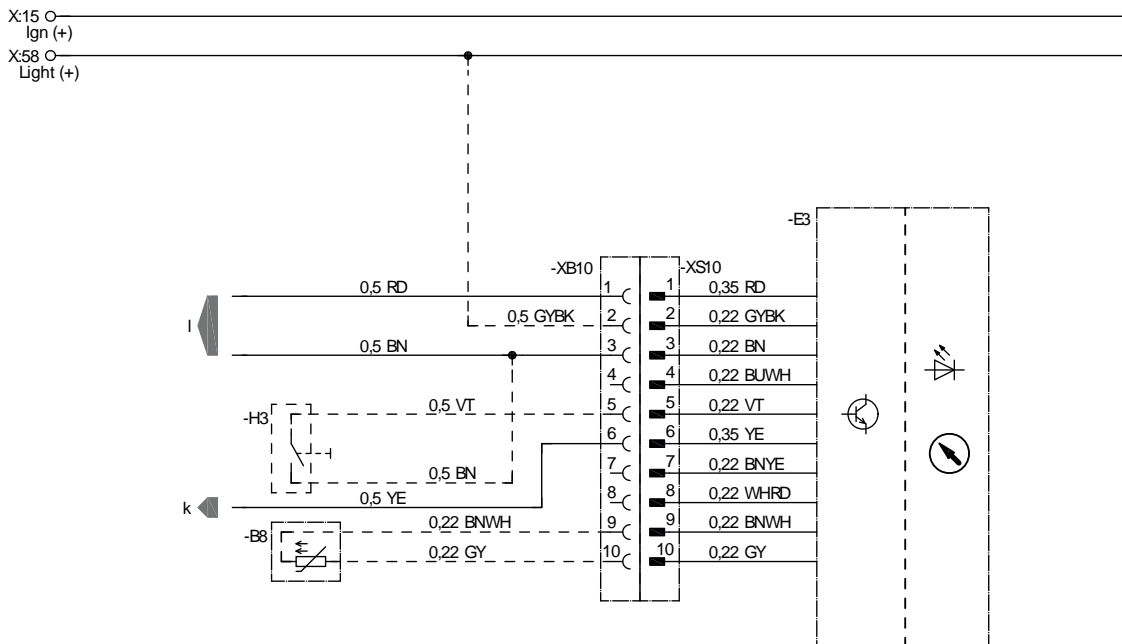

22 1000 34 97 46

- B8 Sensor, interior temperature
- E3 EasyStart Timer
- H3 EasyStart Timer button
- k to the upgrade box or relay circuit for water pump and vehicle fan connection (max. 500 mA)
- I to the upgrade box

#### CABLE COLOURS

RD	red	GY	grey	BK	black
BU	blue	YE	yellow	GN	green
WH	white	VT	violet	BN	brown

## 5 CIRCUIT DIAGRAM

### EASYSTART TIMER WITH BUTTON CONNECTION

Airtronic, Airtronic M, Airtronic L with control temperature sensor external, interior, e.g. for fresh air mode

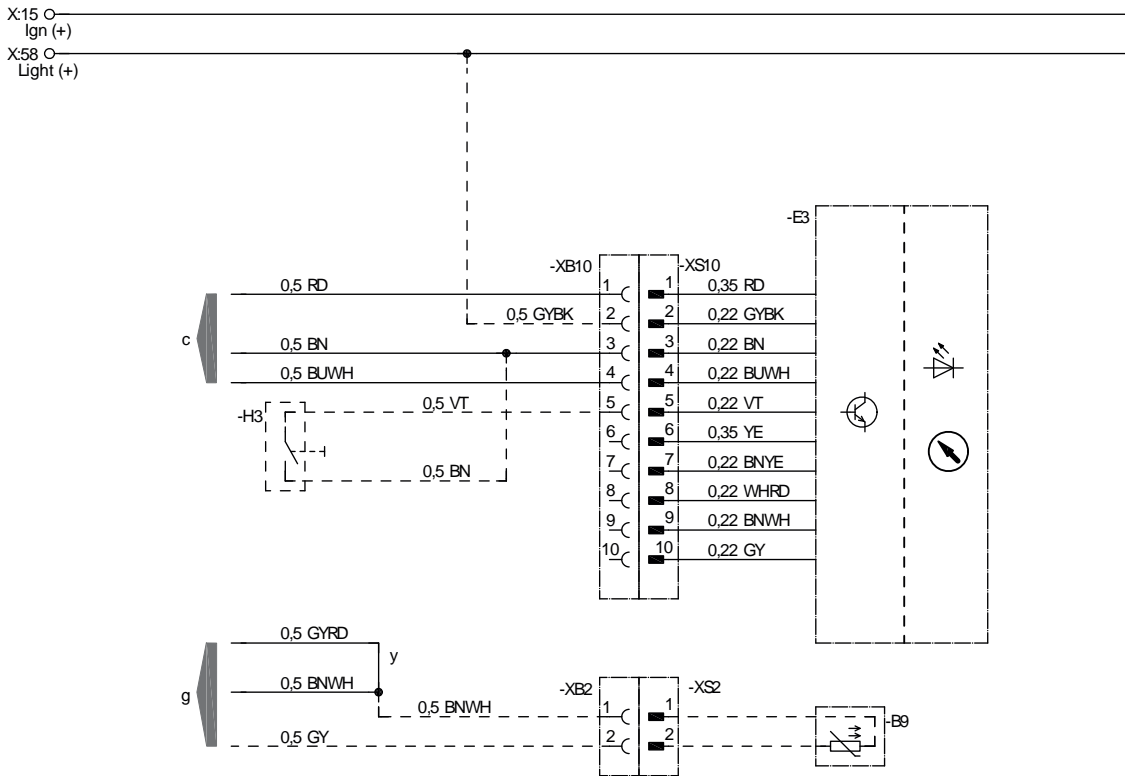

22 1000 34 97 12

- B9 External control temperature sensor, interior
- E3 EasyStart Timer
- H3 EasyStart Timer button
- c to the heater
- g to the heater
- y Connect cables and insulate

#### CABLE COLOURS

RD	red	GY	grey	BK	black
BU	blue	YE	yellow	GN	green
WH	white	VT	violet	BN	brown

## 5 CIRCUIT DIAGRAM

### EASYSTART TIMER CONNECTION

1st heater via the diagnostics cable

Hydronic, Hydronic II, Hydronic II C, Hydronic II Comfort, Hydronic M II

2nd heater via the diagnostics cable

Hydronic, Hydronic II, Hydronic II C, Hydronic II Comfort, Hydronic M II

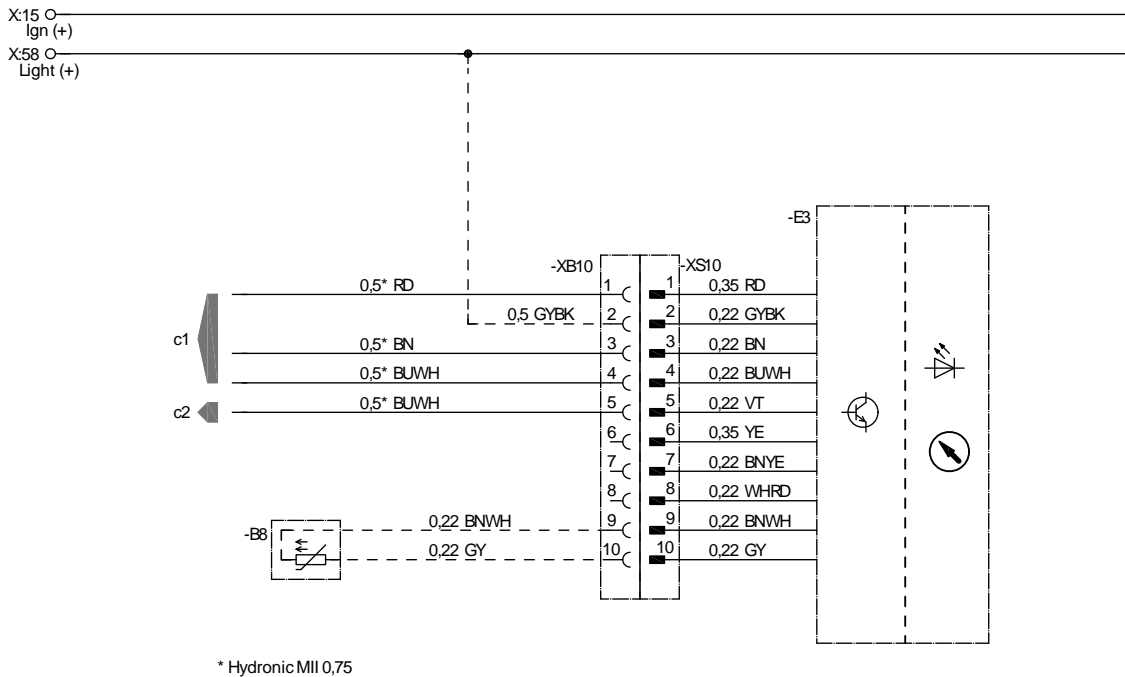

22 1000 34 97 06

- B8 Sensor, interior temperature
- E3 EasyStart Timer
- c1 to heater 1
- c2 to heater 2

#### CABLE COLOURS

RD	red	GY	grey	BK	black
BU	blue	YE	yellow	GN	green
WH	white	VT	violet	BN	brown

## 5 CIRCUIT DIAGRAM

### EASYSTART TIMER CONNECTION

1st heater via the diagnostics cable

Hydronic, Hydronic II, Hydronic II C, Hydronic II Comfort, Hydronic M II

2nd heater via switch-on signal S+

Hydronic, Hydronic II, Hydronic II C, Hydronic II Comfort, Hydronic M II, Hydronic L II

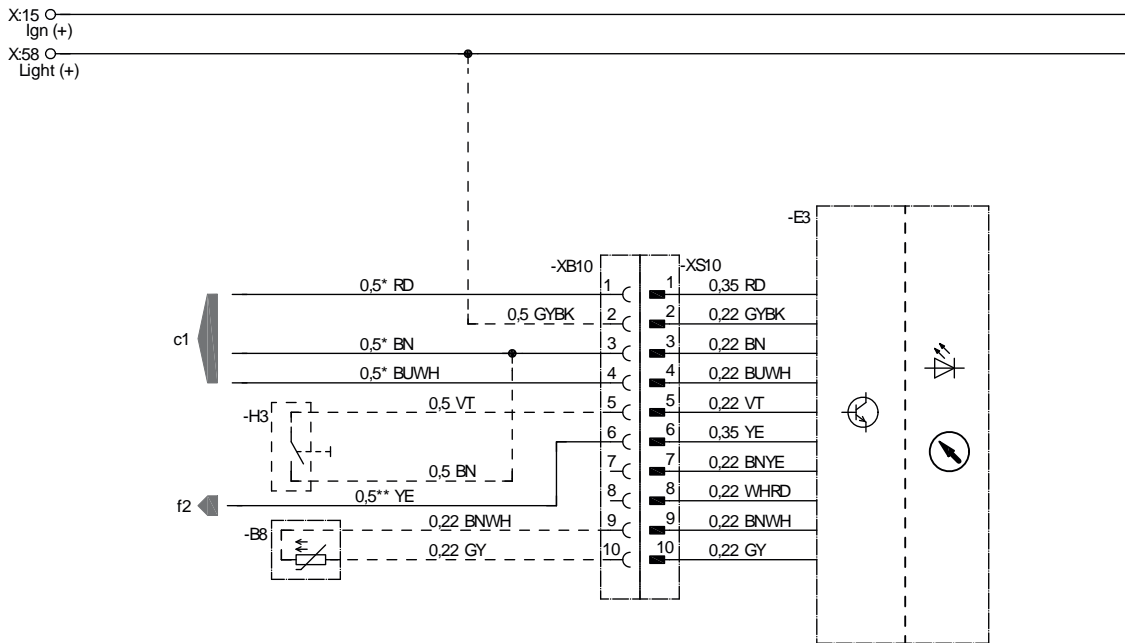

22 1000 34 97 04

- B8 Sensor, interior temperature
- E3 EasyStart Timer
- H3 EasyStart Timer button
- c1 to heater 1
- f2 Switch-on signal S+, heater 2

### CABLE COLOURS

RD	red	GY	grey	BK	black
BU	blue	YE	yellow	GN	green
WH	white	VT	violet	BN	brown



## 5 CIRCUIT DIAGRAM

### EASYSTART TIMER CONNECTION

1st heater via the diagnostics cable

Hydronic, Hydronic II, Hydronic II C, Hydronic II Comfort, Hydronic M II

2nd heater via the diagnostics cable

Airtronic, Airtronic M, Airtronic L

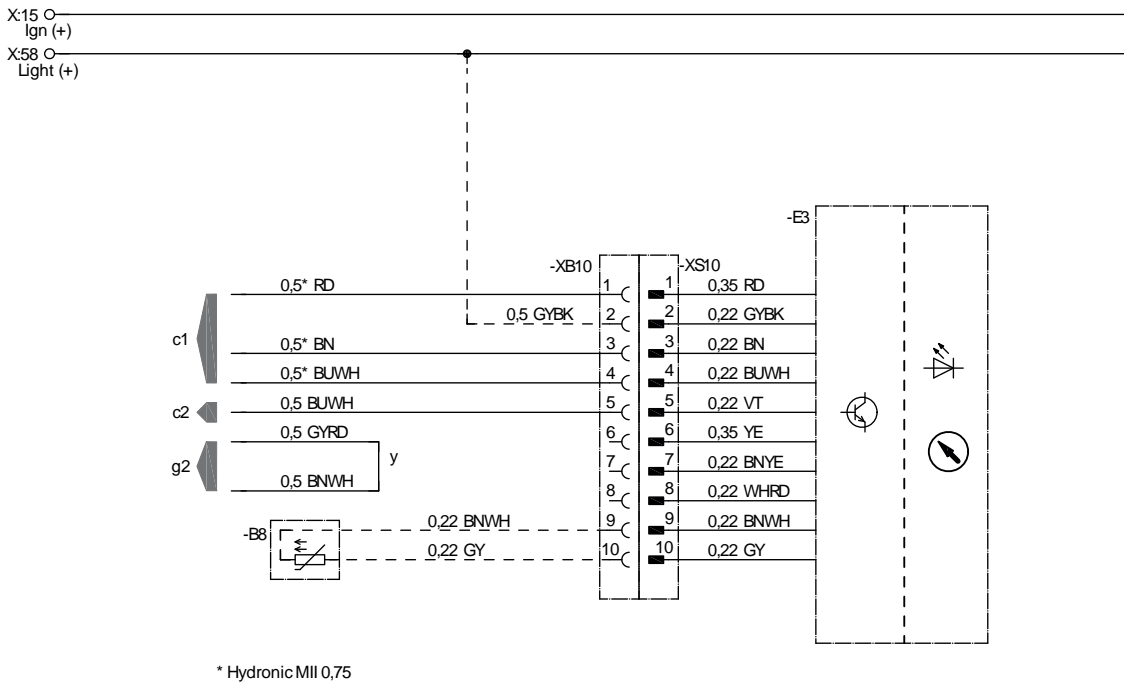

\* Hydronic MII 0,75

22 1000 34 97 05

- B8 Sensor, interior temperature
- E3 EasyStart Timer
- c1 to heater 1
- c2 to heater 2
- g2 to heater 2
- y Connect cables and insulate

#### CABLE COLOURS

RD	red	GY	grey	BK	black
BU	blue	YE	yellow	GN	green
WH	white	VT	violet	BN	brown

## 5 CIRCUIT DIAGRAM

### EASYSTART TIMER CONNECTION

1st heater via the diagnostics cable  
Airtronic, Airtronic M, Airtronic L

2nd heater via the diagnostics cable  
Airtronic, Airtronic M, Airtronic L

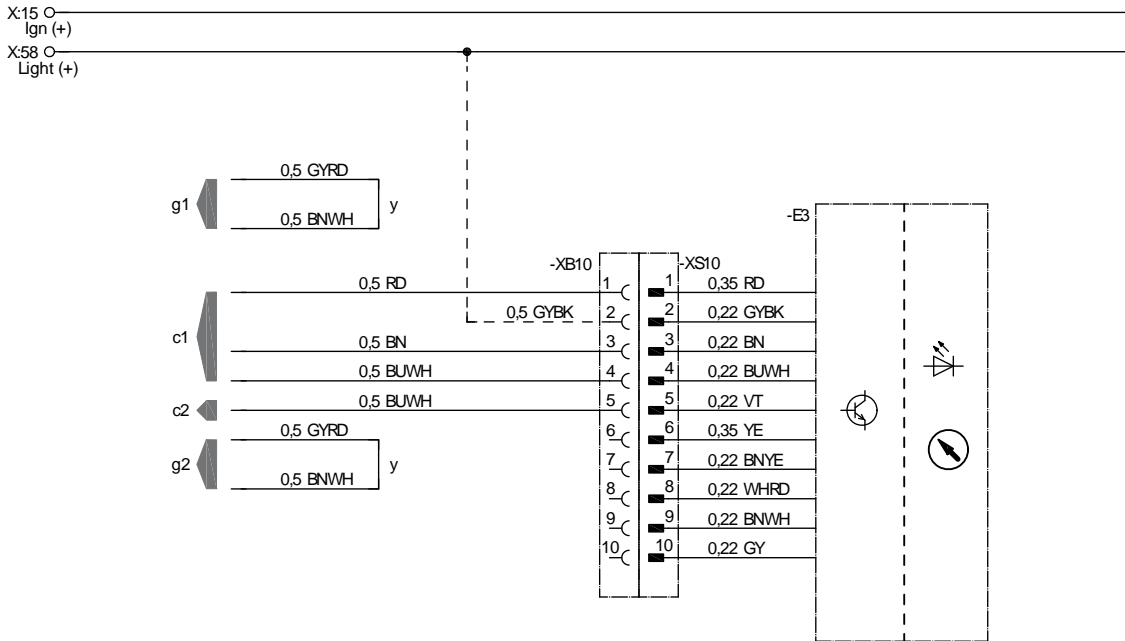

22 1000 34 97 14

- E3 EasyStart Timer
- c1 to heater 1
- c2 to heater 2
- g1 to heater 1
- g2 to heater 2
- y Connect cables and insulate

#### CABLE COLOURS

RD	red	GY	grey	BK	black
BU	blue	YE	yellow	GN	green
WH	white	VT	violet	BN	brown

## 5 CIRCUIT DIAGRAM

### EASYSTART TIMER CONNECTION

1st heater via the diagnostics cable

Airtronic, Airtronic M, Airtronic L

2nd heater via switch-on signal S+

Hydronic, Hydronic II, Hydronic II C, Hydronic II Comfort, Hydronic M II, Hydronic L II

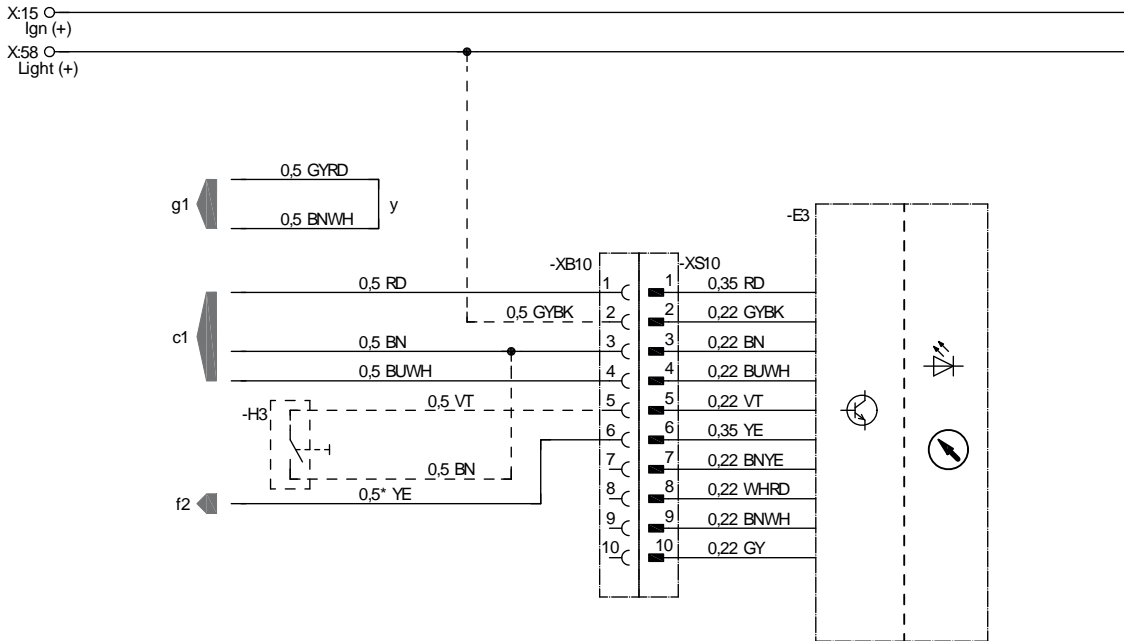

\* Hydronic MII 0,75 / Hydronic L 1,0

22 1000 34 97 15

- B8 Sensor, interior temperature
- E3 EasyStart Timer
- H3 Button
- c1 to heater 1
- f2 Switch-on signal S+, heater 2
- g1 to heater 1
- y Connect cables and insulate

#### CABLE COLOURS

RD	red	GY	grey	BK	black
BU	blue	YE	yellow	GN	green
WH	white	VT	violet	BN	brown

## 5 CIRCUIT DIAGRAM

### COMBINATION OF EASYSTART TIMER WITH EASYSTART TIMER

Hydronic, Hydronic II, Hydronic II C, Hydronic II Comfort, Hydronic M II

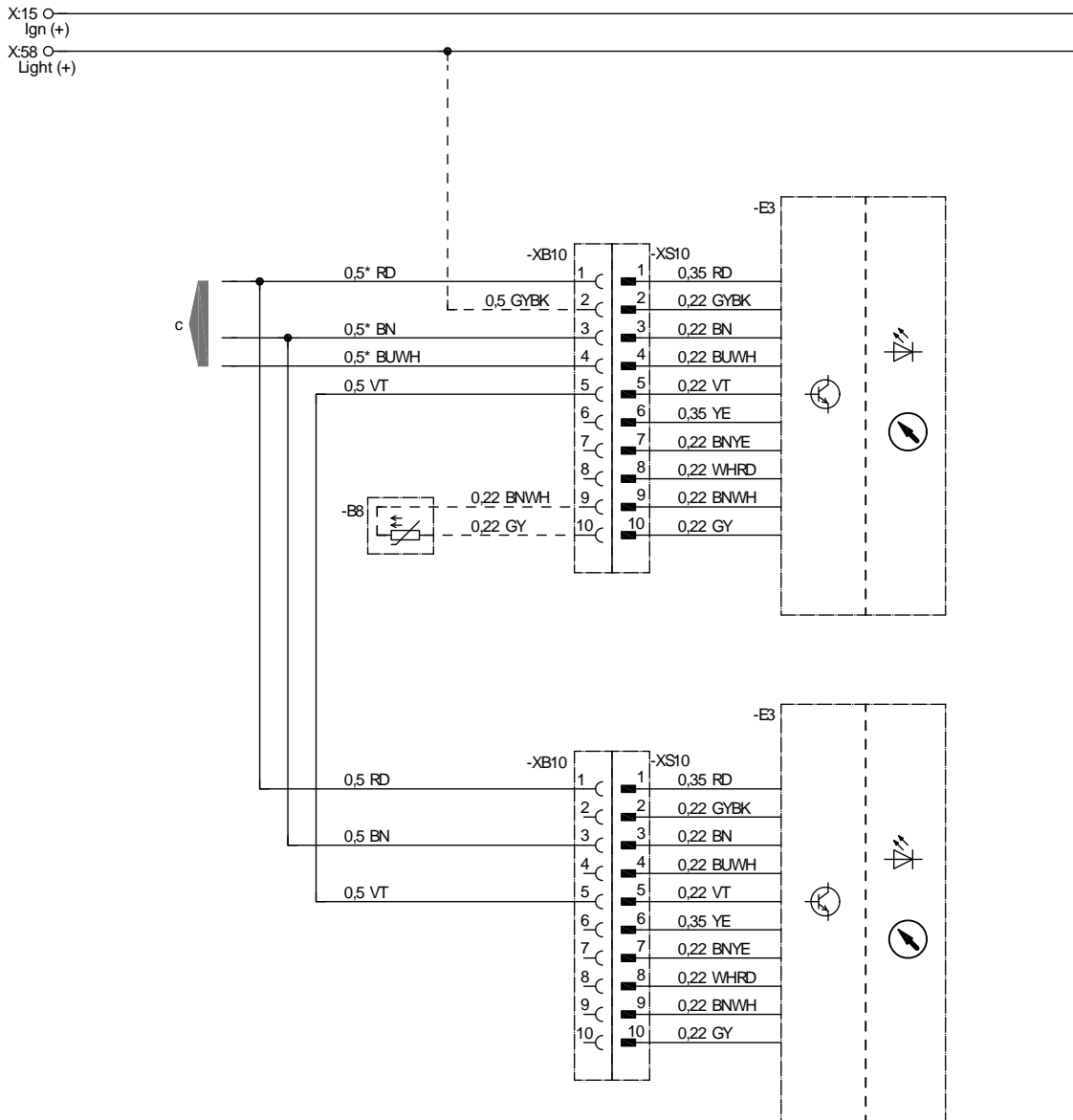

\* Hydronic MII 0,75

22 1000 34 97 08

- B8 Sensor, interior temperature
- E3 EasyStart Timer
- c to the heater

#### CABLE COLOURS

RD	red	GY	grey	BK	black
BU	blue	YE	yellow	GN	green
WH	white	VT	violet	BN	brown

## 5 CIRCUIT DIAGRAM

COMBINATION OF EASYSTART TIMER WITH EASYSTART TIMER AND CONNECTION VIA SWITCH-ON SIGNAL S+  
Hydronic, Hydronic II, Hydronic II C, Hydronic II Comfort, Hydronic M II, Hydronic, L II

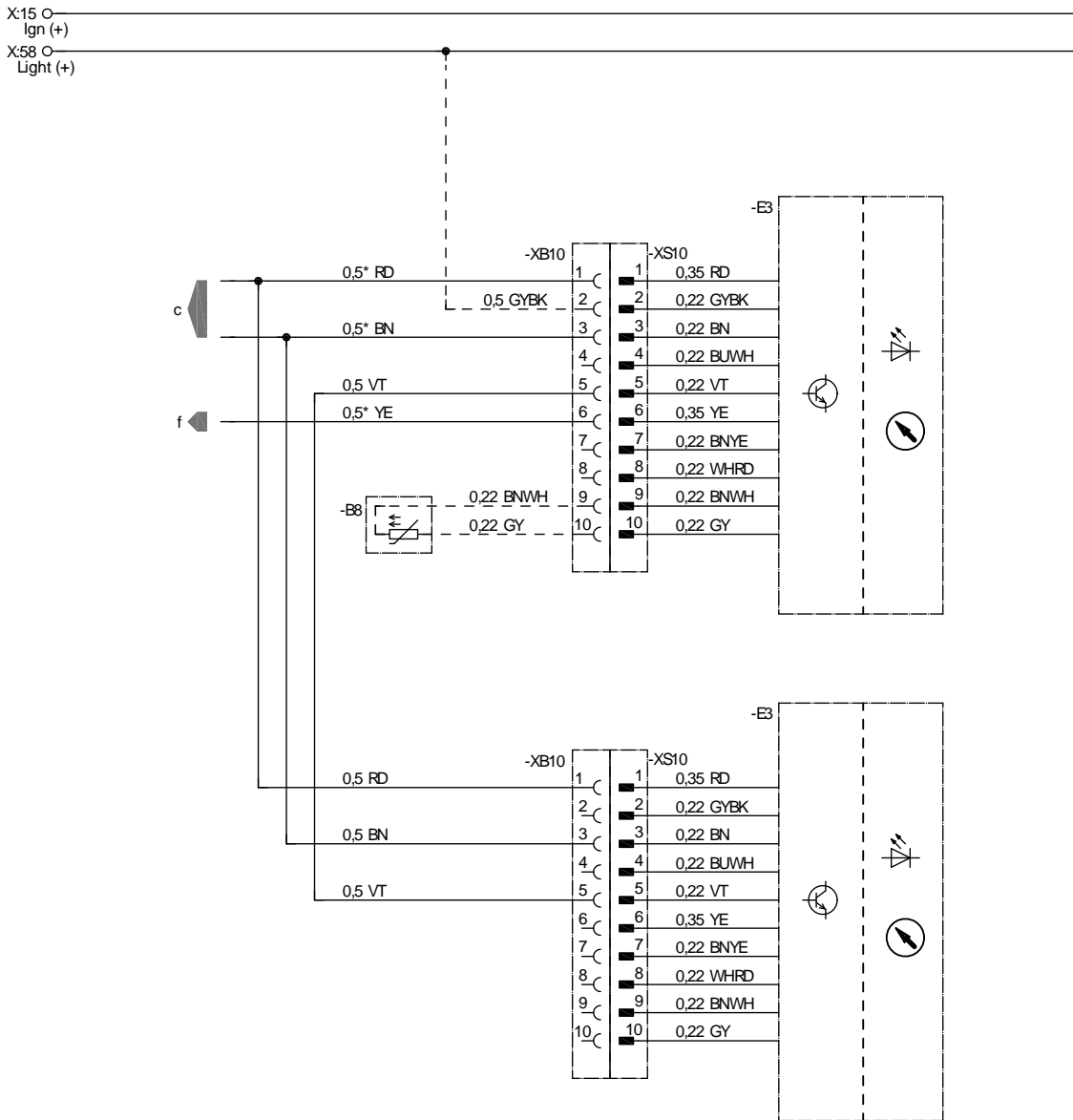

\* Hydronic MII 0,75 / Hydronic L 1,0

22 1000 34 97 51

- B8 Sensor, interior temperature
- E3 EasyStart Timer
- c to the heater
- f Switch-on signal S+

### CABLE COLOURS

RD	red	GY	grey	BK	black
BU	blue	YE	yellow	GN	green
WH	white	VT	violet	BN	brown

# 5 CIRCUIT DIAGRAM

COMBINATION OF EASYSTART TIMER WITH EASYSTART TIMER  
 Airtronic, Airtronic M, Airtronic L

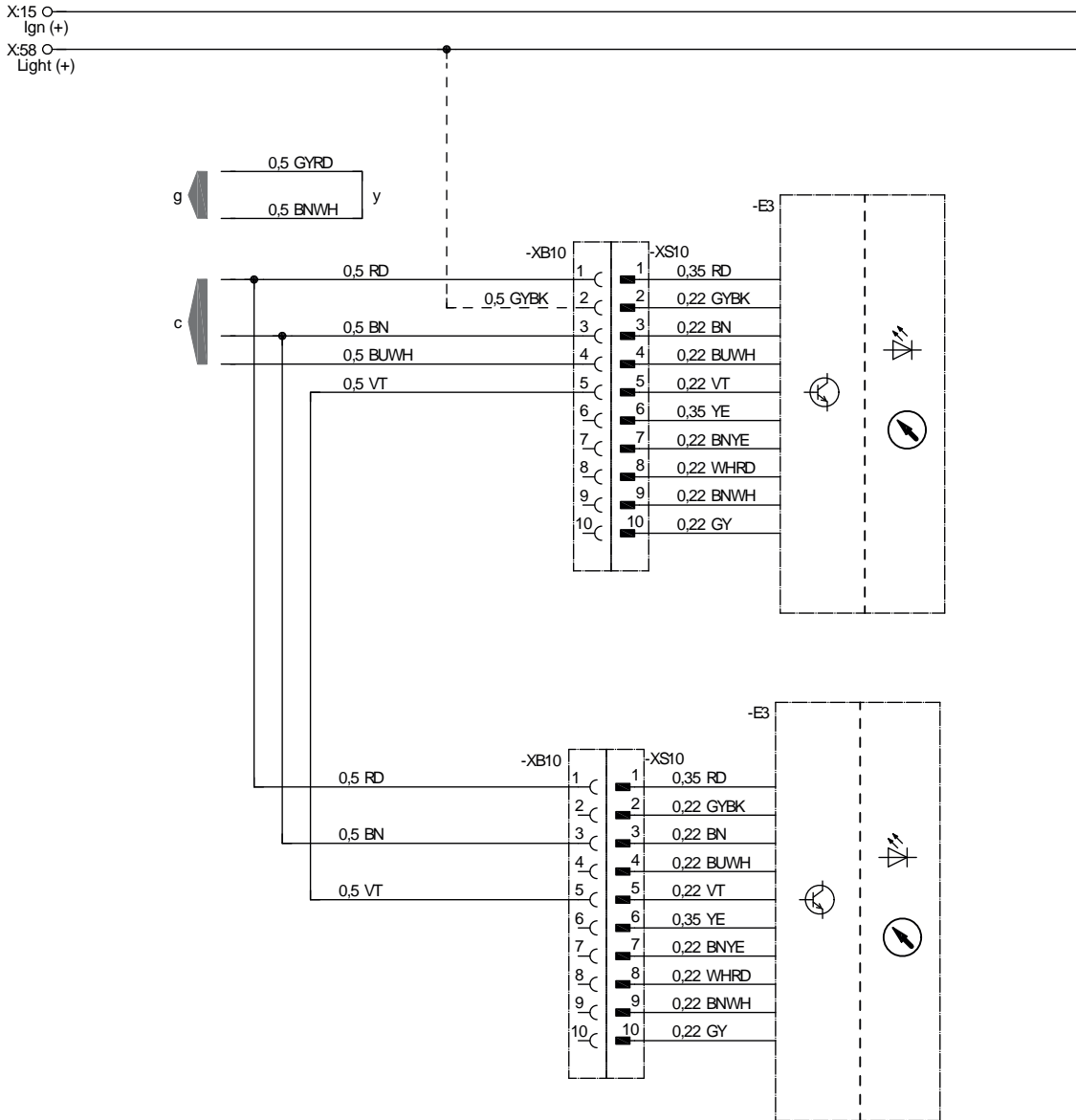

22 1000 34 97 13

-E3 EasyStart Timer  
 c to the heater  
 g to the heater

**CABLE COLOURS**

RD	red	GY	grey	BK	black
BU	blue	YE	yellow	GN	green
WH	white	VT	violet	BN	brown

## 5 CIRCUIT DIAGRAM

COMBINATION OF EASYSTART TIMER WITH EASYSTART REMOTE  
 Hydronic, Hydronic II, Hydronic II C, Hydronic II Comfort, Hydronic M II

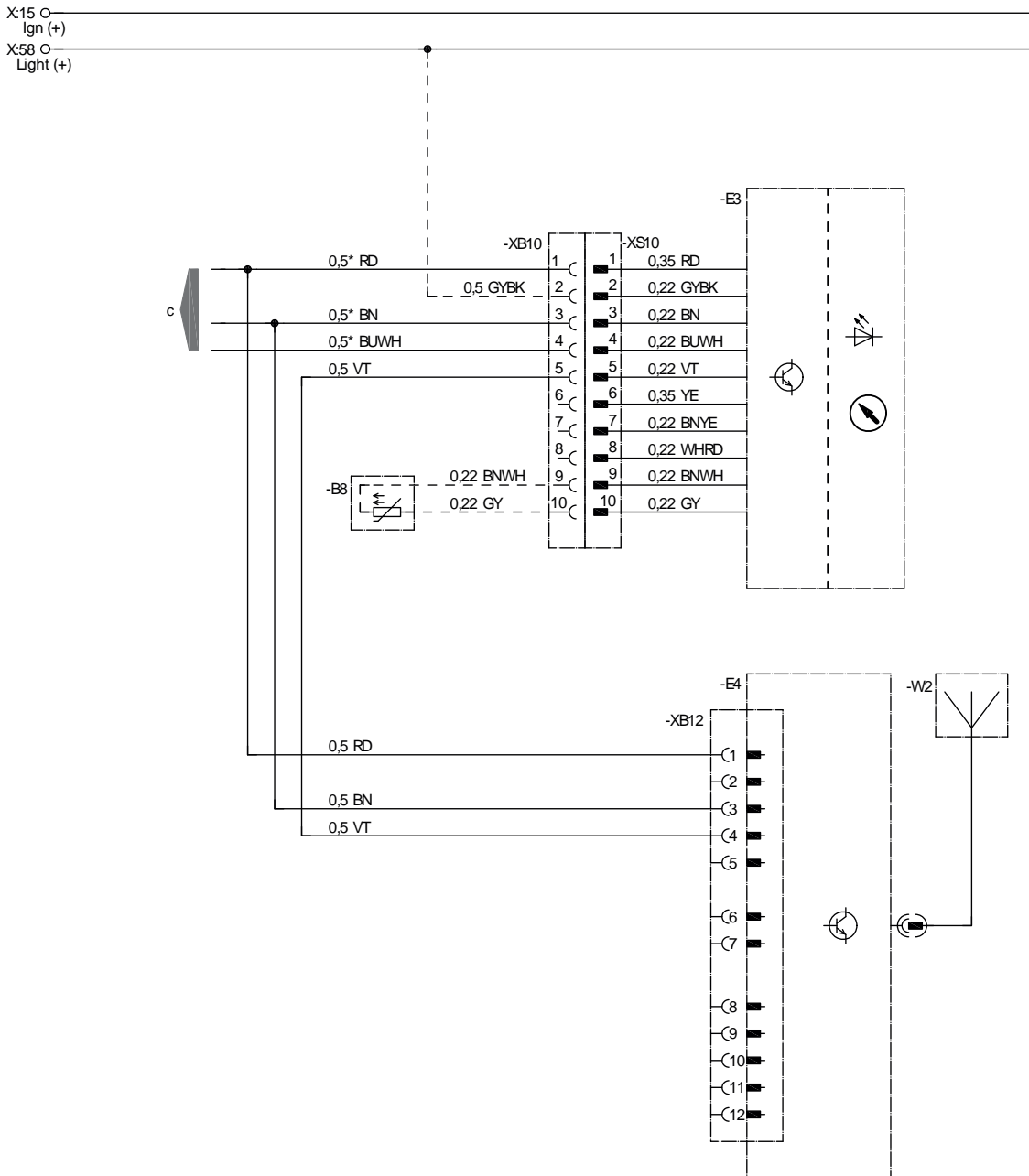

\* Hydronic MII 0,75

22 1000 34 97 40

- B8 Sensor, interior temperature
- E3 EasyStart Timer
- E4 EasyStart Remote radio remote control
- W2 EasyStart Remote / Remote+ antenna
- c to the heater

### CABLE COLOURS

RD	red	GY	grey	BK	black
BU	blue	YE	yellow	GN	green
WH	white	VT	violet	BN	brown

## 5 CIRCUIT DIAGRAM

### COMBINATION OF EASYSTART TIMER WITH EASYSTART REMOTE Airtronic, Airtronic M, Airtronic L

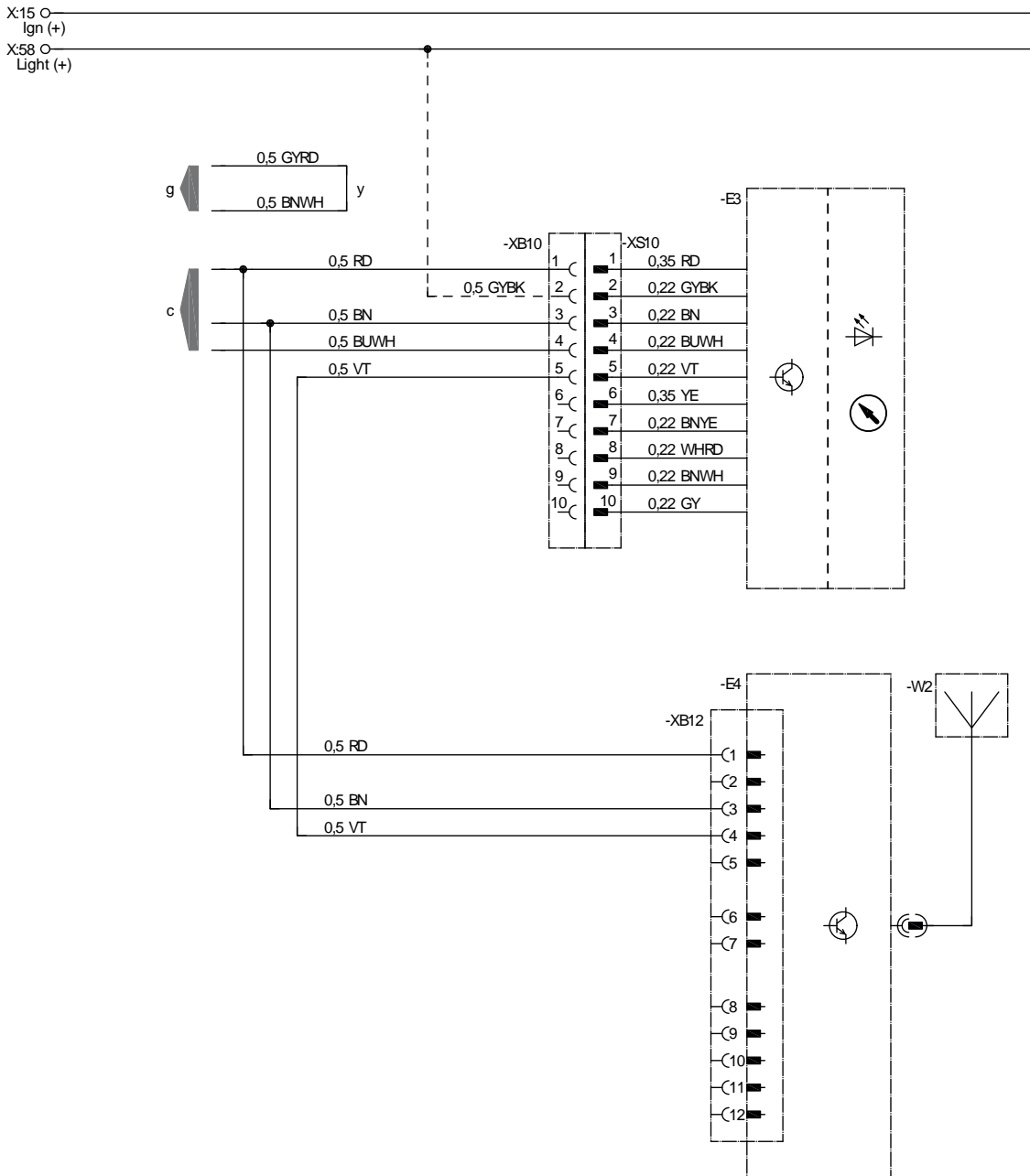

22 1000 34 97 43

- E3 EasyStart Timer
- E4 EasyStart Remote radio remote control
- W2 EasyStart Remote / Remote+ antenna
- c to the heater
- g to the heater

#### CABLE COLOURS

RD	red	GY	grey	BK	black
BU	blue	YE	yellow	GN	green
WH	white	VT	violet	BN	brown



## 5 CIRCUIT DIAGRAM

COMBINATION OF EASYSTART TIMER WITH EASYSTART REMOTE AND CONNECTION VIA SWITCH-ON SIGNAL S+  
Hydronic, Hydronic II, Hydronic II C, Hydronic II Comfort, Hydronic M II, Hydronic, L II

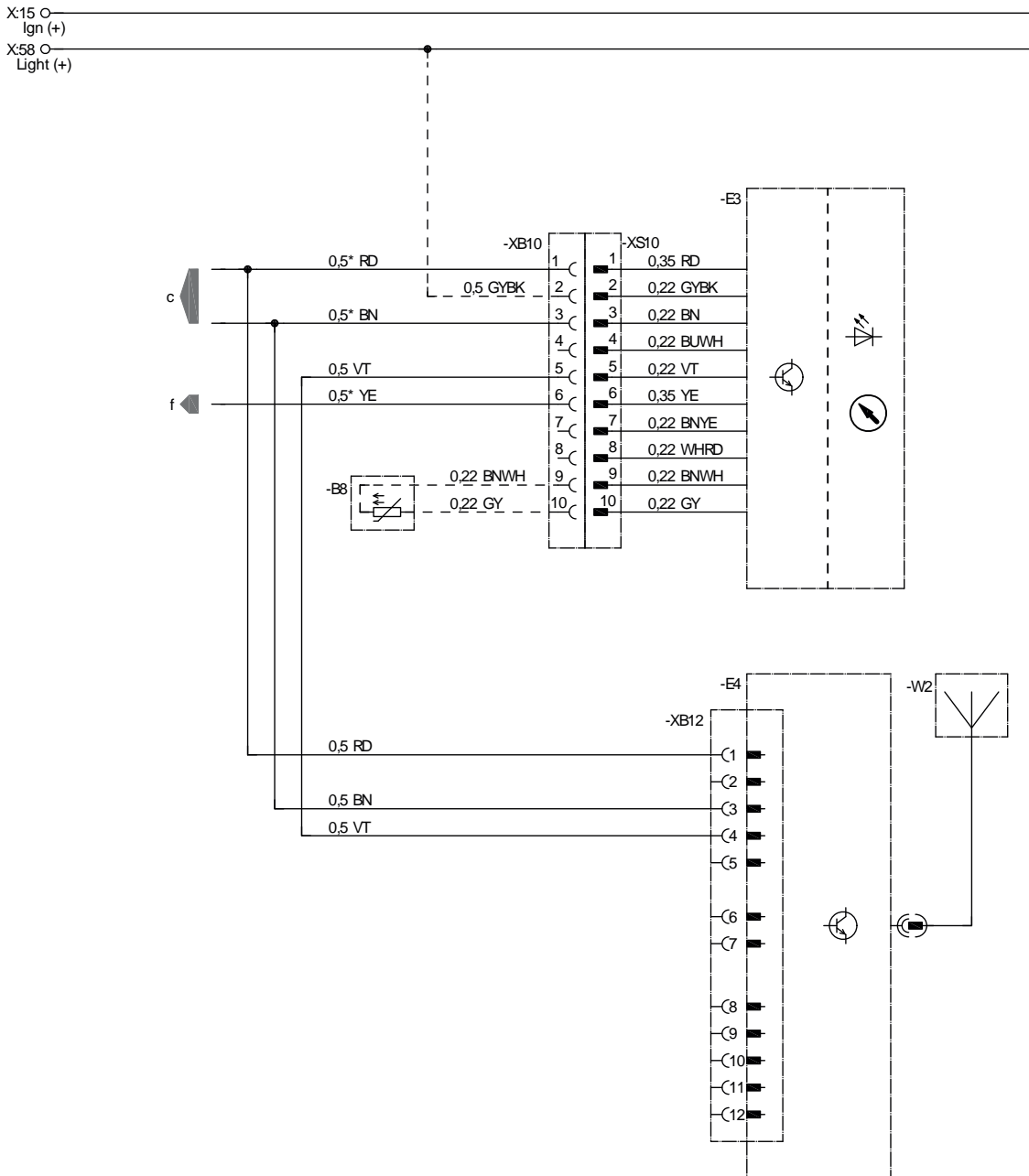

\* Hydronic MII 0,75 / Hydronic L 1,0

22 1000 34 97 49

- B8 Sensor, interior temperature
- E3 EasyStart Timer
- E4 EasyStart Remote radio remote control
- W2 EasyStart Remote / Remote+ antenna
- c to the heater
- f Switch-on signal S+

### CABLE COLOURS

RD	red	GY	grey	BK	black
BU	blue	YE	yellow	GN	green
WH	white	VT	violet	BN	brown

## 5 CIRCUIT DIAGRAM

### COMBINATION OF EASYSTART TIMER WITH EASYSTART SELECT

Hydronic, Hydronic II, Hydronic II C, Hydronic II Comfort, Hydronic M II

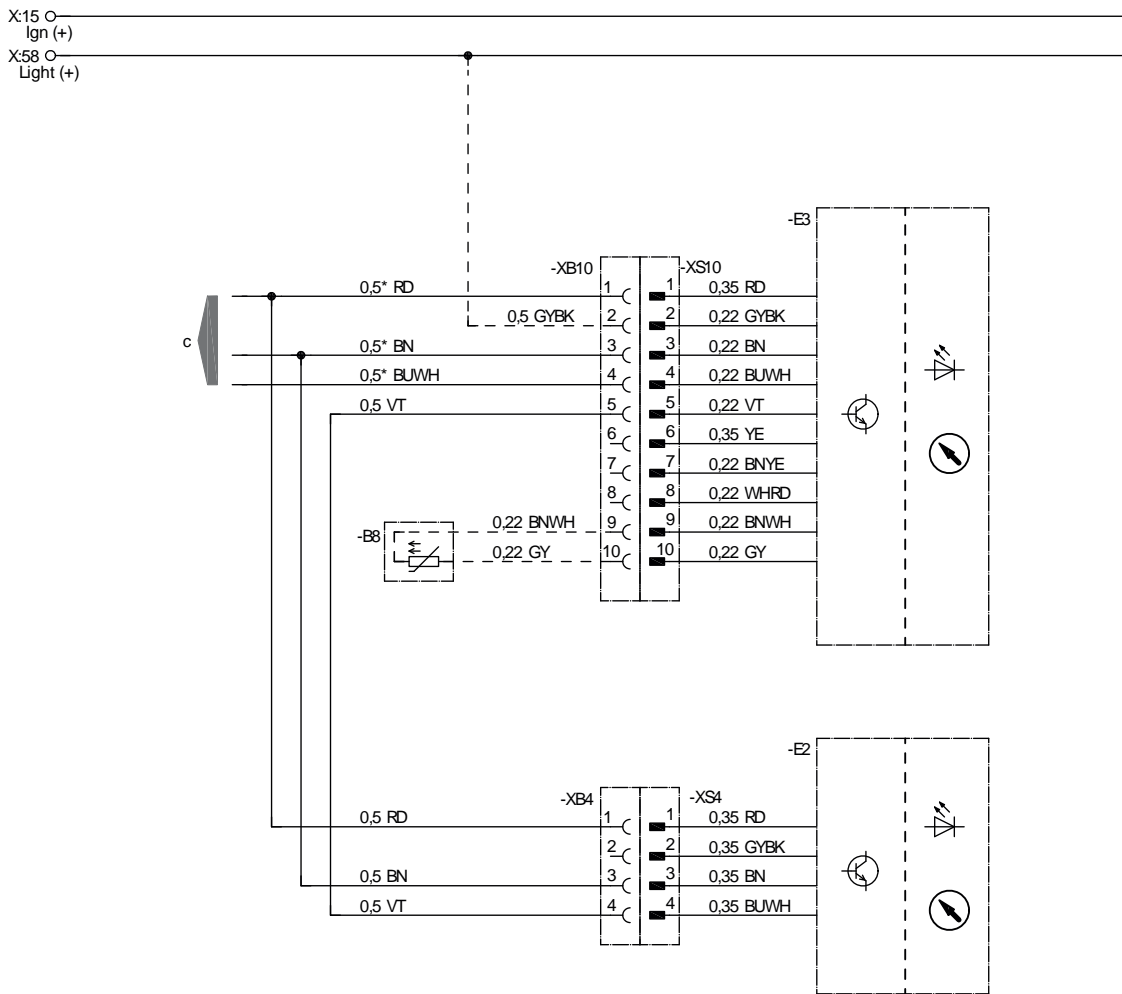

\* Hydronic MII 0,75

22 1000 34 97 41

- B8 Sensor, interior temperature
- E2 EasyStart Select control unit
- E3 EasyStart Timer
- c to the heater

#### CABLE COLOURS

RD	red	GY	grey	BK	black
BU	blue	YE	yellow	GN	green
WH	white	VT	violet	BN	brown

# 5 CIRCUIT DIAGRAM

COMBINATION OF EASYSTART TIMER WITH EASYSTART SELECT  
 Airtronic, Airtronic M, Airtronic L

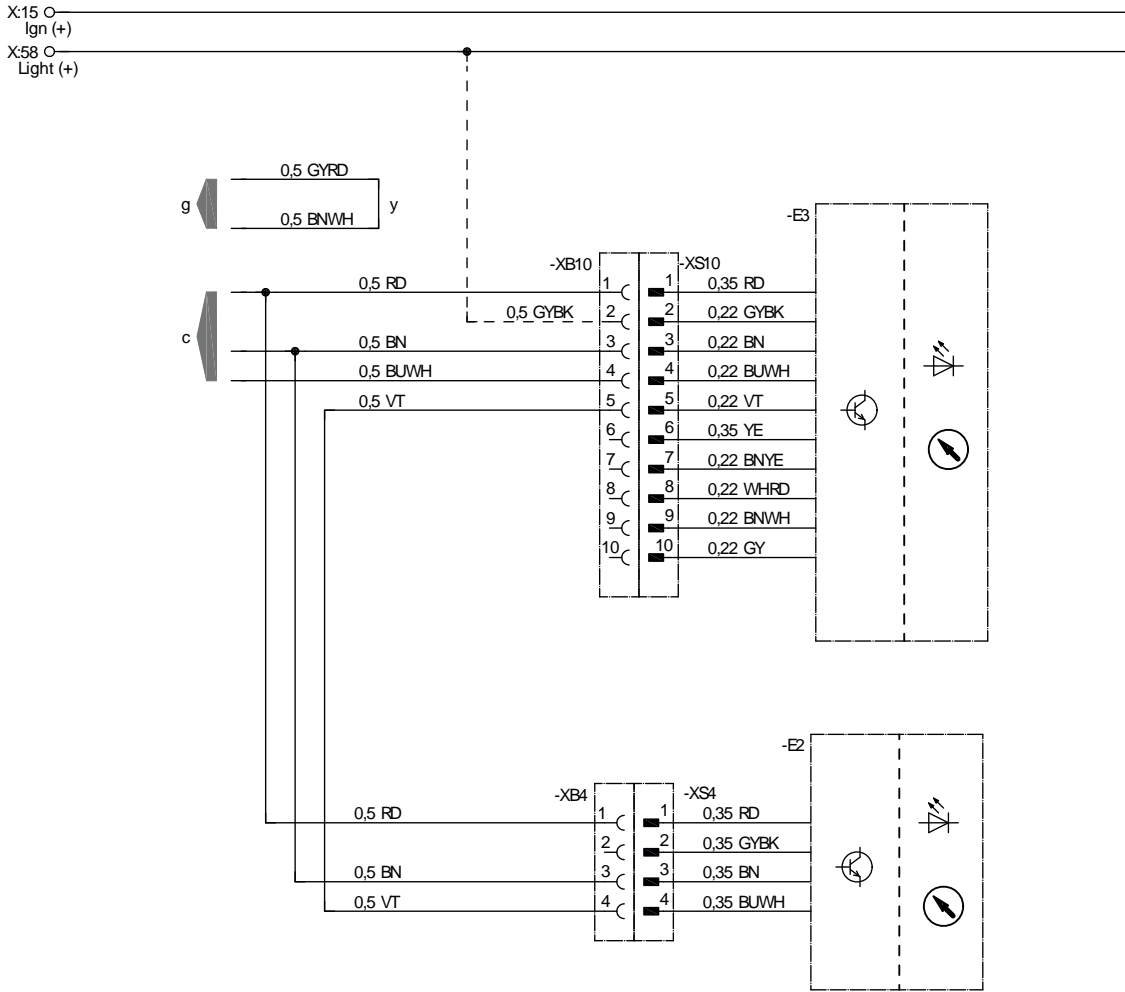

22 1000 34 97 44

- E2 EasyStart Select control unit
- E3 EasyStart Timer
- c to the heater
- g to the heater

**CABLE COLOURS**

RD	red	GY	grey	BK	black
BU	blue	YE	yellow	GN	green
WH	white	VT	violet	BN	brown

## 5 CIRCUIT DIAGRAM

COMBINATION OF EASYSTART TIMER WITH EASYSTART SELECT AND CONNECTION VIA SWITCH-ON SIGNAL S+  
 Hydronic, Hydronic II, Hydronic II C, Hydronic II Comfort, Hydronic M II, Hydronic, L II

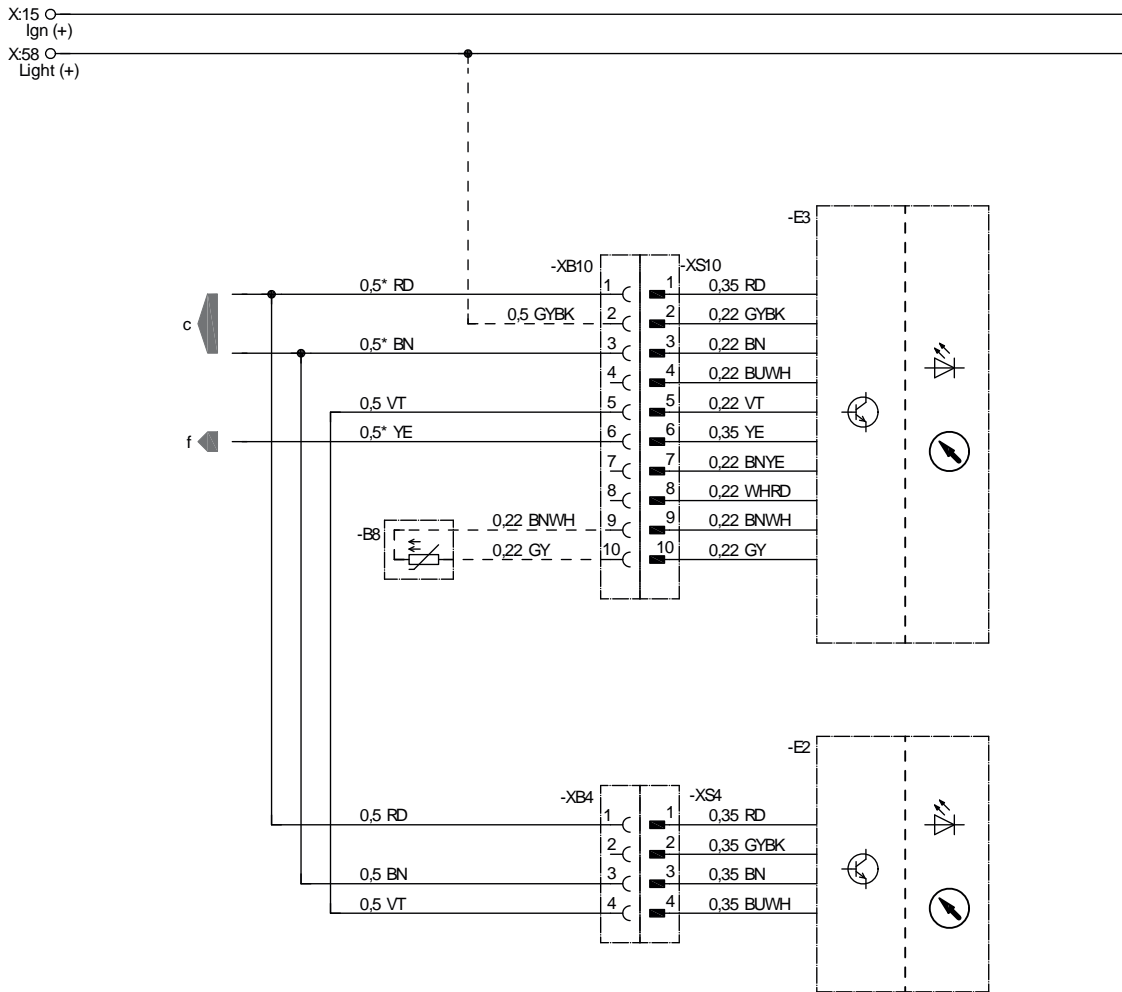

\* Hydronic MII 0,75 / Hydronic L 1,0

22 1000 34 97 48

- B8 Sensor, interior temperature
- E2 EasyStart Select control unit
- E3 EasyStart Timer
- c to the heater
- f Switch-on signal S+

### CABLE COLOURS

RD	red	GY	grey	BK	black
BU	blue	YE	yellow	GN	green
WH	white	VT	violet	BN	brown

# 5 CIRCUIT DIAGRAM

## COMBINATION OF EASYSTART TIMER WITH EASYSTART TIMER

1st heater via diagnostics cable

Hydronic, Hydronic II, Hydronic II C, Hydronic II Comfort, Hydronic M II

2nd heater via switch-on signal S+

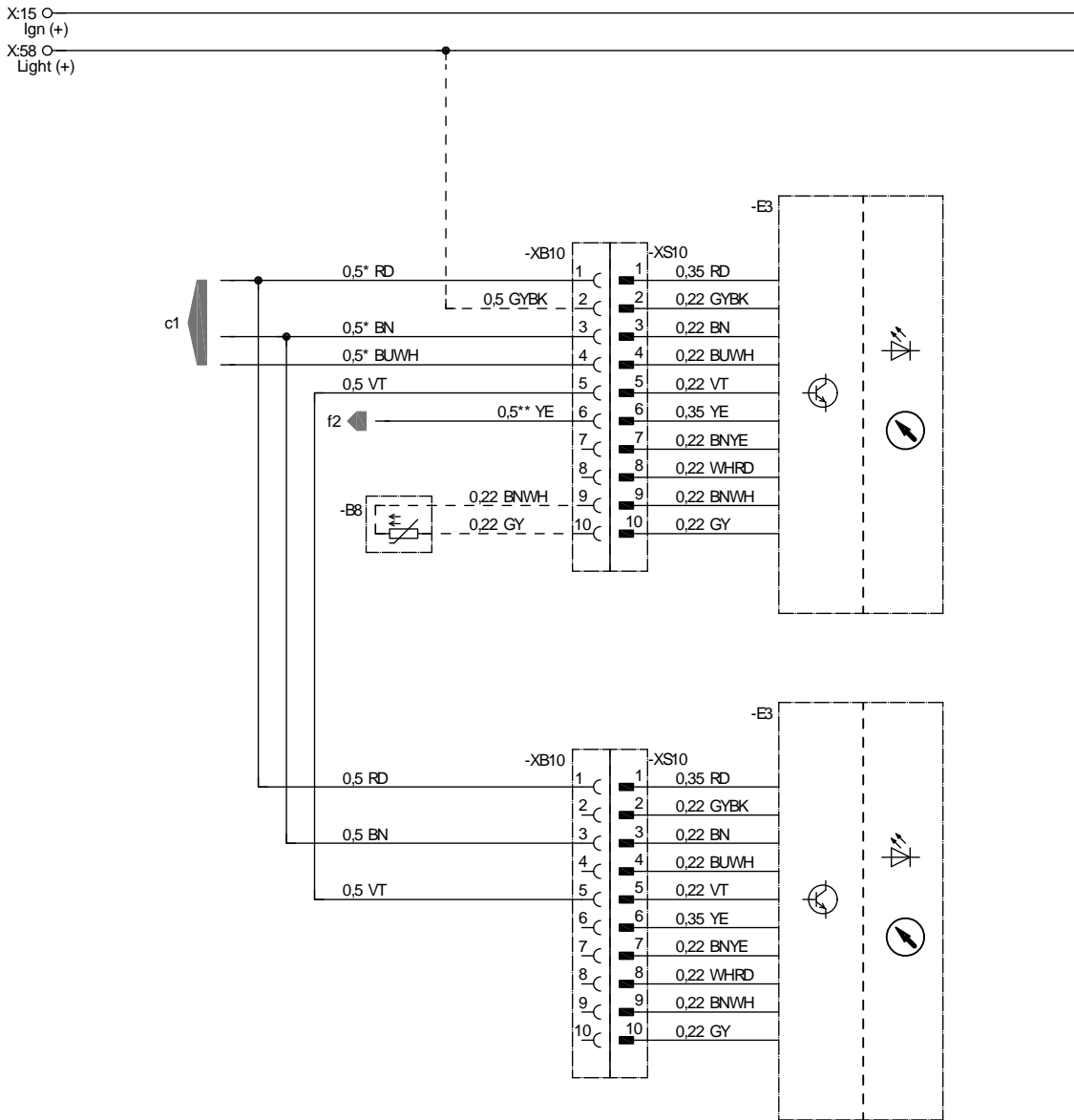

\* Hydronic MII 0,75  
 \*\* Hydronic MII 0,75 / Hydronic L 1,0

22 1000 34 97 09

- B8 Sensor, interior temperature
- E3 EasyStart Timer
- c1 to heater 1
- f2 Switch-on signal S+, heater 2

### CABLE COLOURS

RD	red	GY	grey	BK	black
BU	blue	YE	yellow	GN	green
WH	white	VT	violet	BN	brown

# 5 CIRCUIT DIAGRAM

## COMBINATION OF EASYSTART TIMER WITH EASYSTART TIMER

1st heater via diagnostics cable  
 Airtronic, Airtronic M, Airtronic L  
 2nd heater via switch-on signal S+

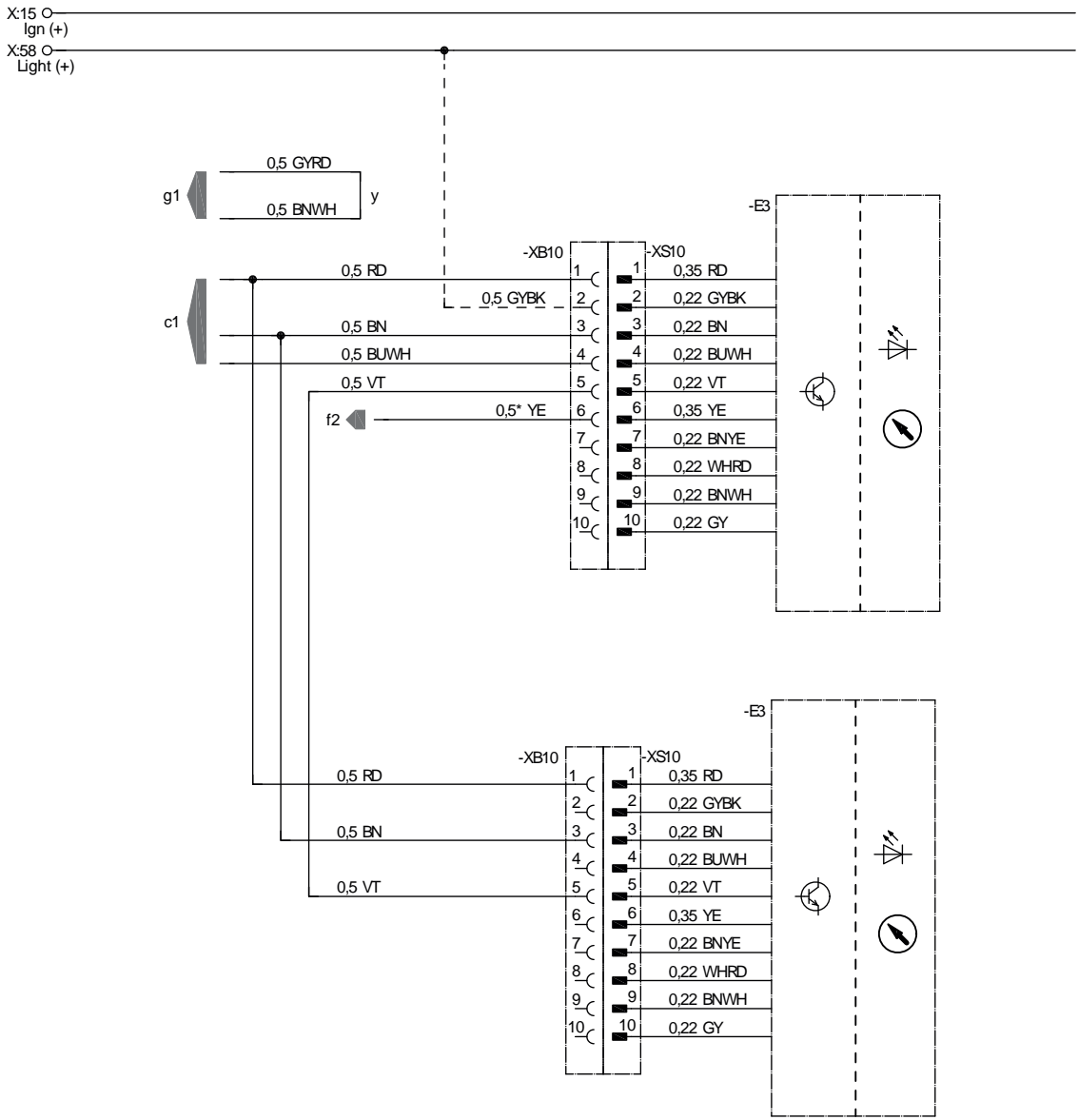

\* Hydronic MII 0,75/ Hydronic L 1,0

- E3 EasyStart Timer
- c1 to heater 1
- f2 Switch-on signal S+, heater 2
- g1 to heater 1

**CABLE COLOURS**

RD	red	GY	grey	BK	black
BU	blue	YE	yellow	GN	green
WH	white	VT	violet	BN	brown

## 5 CIRCUIT DIAGRAM

### EASYSTART TIMER CONNECTION

Hydronic, Hydronic II, Hydronic II C, Hydronic II Comfort, Hydronic M II with temperature control

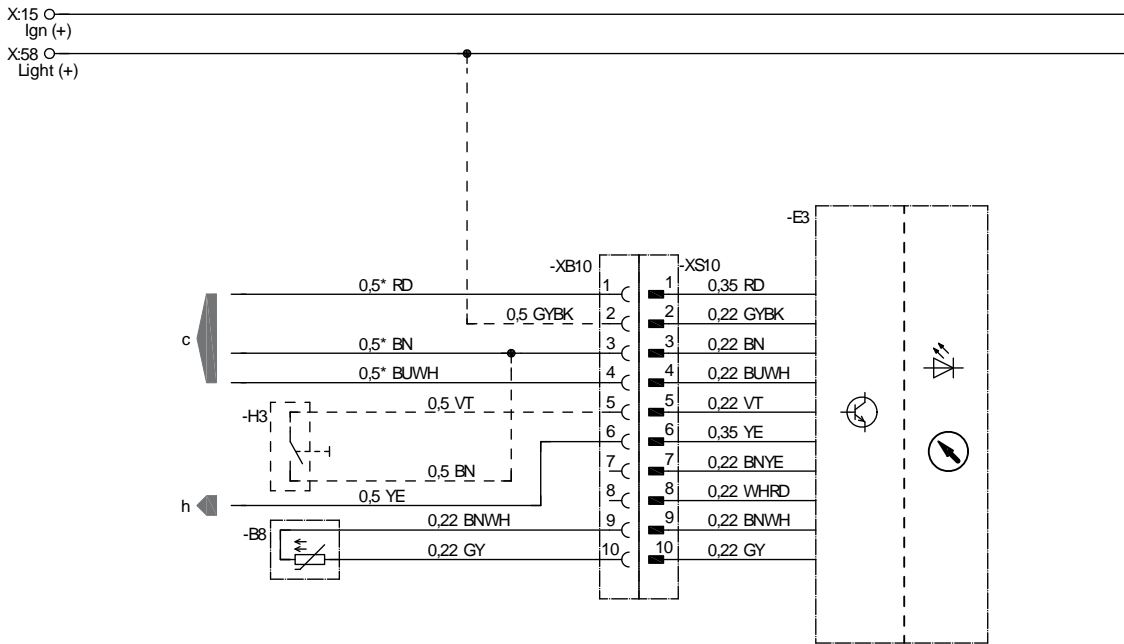

\* Hydronic MII 0,75

22 1000 34 97 07

- B8 Sensor, interior temperature
- E3 EasyStart Timer
- H3 EasyStart Timer button
- c to the heater
- h for example, vehicle fan relay activation (max. 500 mA)

#### CABLE COLOURS

RD	red	GY	grey	BK	black
BU	blue	YE	yellow	GN	green
WH	white	VT	violet	BN	brown

## 5 CIRCUIT DIAGRAM

### ADR MODE, EASYSTART TIMER WITH BUTTON CONNECTION

Hydronic II C, Hydronic M II

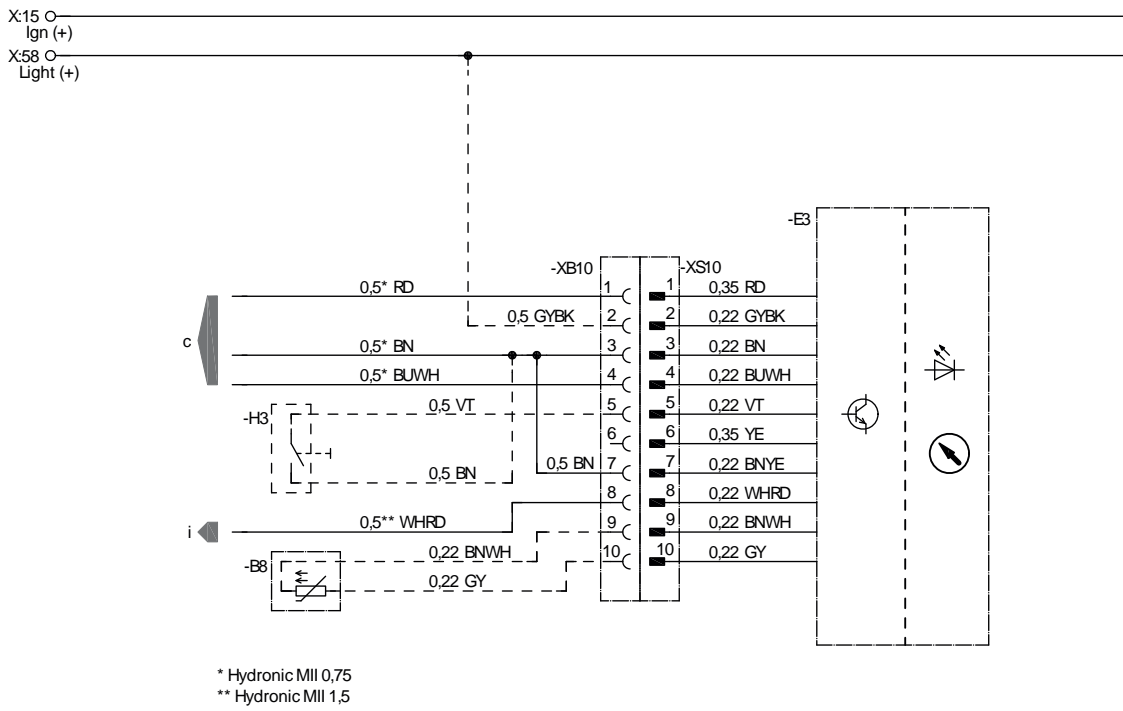

22 1000 34 97 10

- B8 Sensor, interior temperature
- E3 EasyStart Timer
- H3 EasyStart Timer button
- c to the heater
- i ADR feedback from the heater

#### CABLE COLOURS

RD	red	GY	grey	BK	black
BU	blue	YE	yellow	GN	green
WH	white	VT	violet	BN	brown



## 5 CIRCUIT DIAGRAM

### ADR MODE, EASYSTART TIMER WITH BUTTON CONNECTION AND VIA SWITCH-ON SIGNAL S+

Hydronic 24 volt, Hydronic II C, Hydronic M II

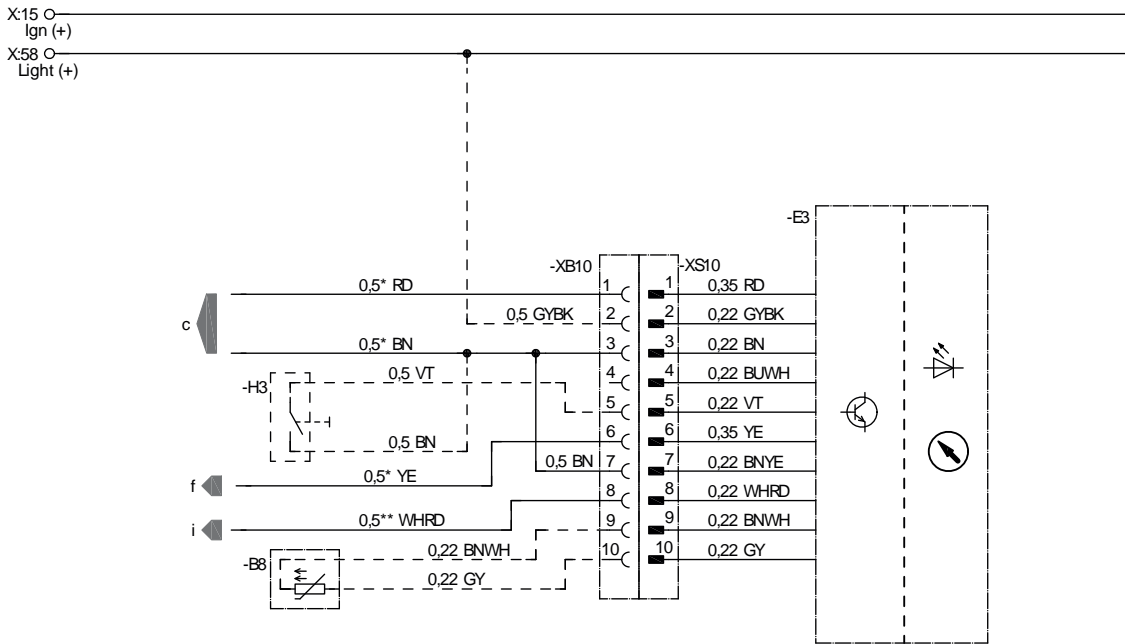

\* Hydronic MII 0,75 / Hydronic L 1,0  
 \*\* Hydronic MII 1,5

22 1000 34 97 50

- B8 Sensor, interior temperature
- E3 EasyStart Timer
- H3 EasyStart Timer button
- c to the heater
- f Switch-on signal S+
- i ADR feedback from the heater

#### CABLE COLOURS

RD	red	GY	grey	BK	black
BU	blue	YE	yellow	GN	green
WH	white	VT	violet	BN	brown

## 5 CIRCUIT DIAGRAM

### ADR MODE, EASYSTART TIMER WITH BUTTON CONNECTION

Airtronic, Airtronic M, Airtronic L

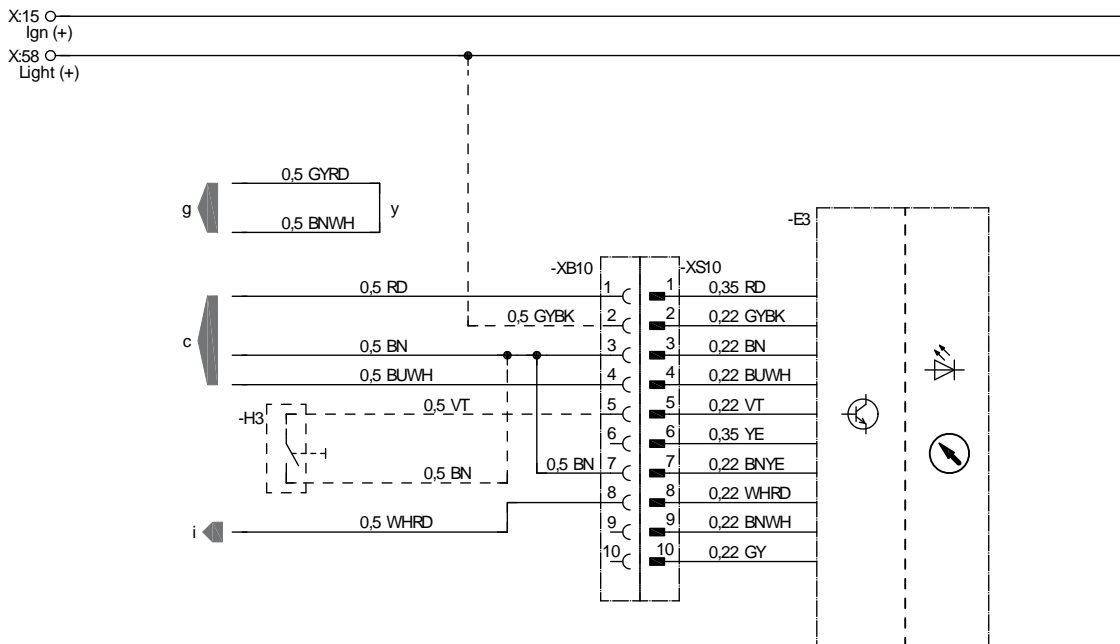

22 1000 34 97 17

- E3 EasyStart Timer
- H3 EasyStart Timer button
- c to the heater
- g to the heater
- i ADR feedback from the heater
- y Connect cables and insulate

#### CABLE COLOURS

RD	red	GY	grey	BK	black
BU	blue	YE	yellow	GN	green
WH	white	VT	violet	BN	brown

## 5 CIRCUIT DIAGRAM

**ADR MODE, COMBINATION OF EASYSTART TIMER WITH EASYSTART TIMER AND CONNECTION VIA SWITCH-ON SIGNAL S+**  
Hydronic 24 volt, Hydronic II C, Hydronic M II

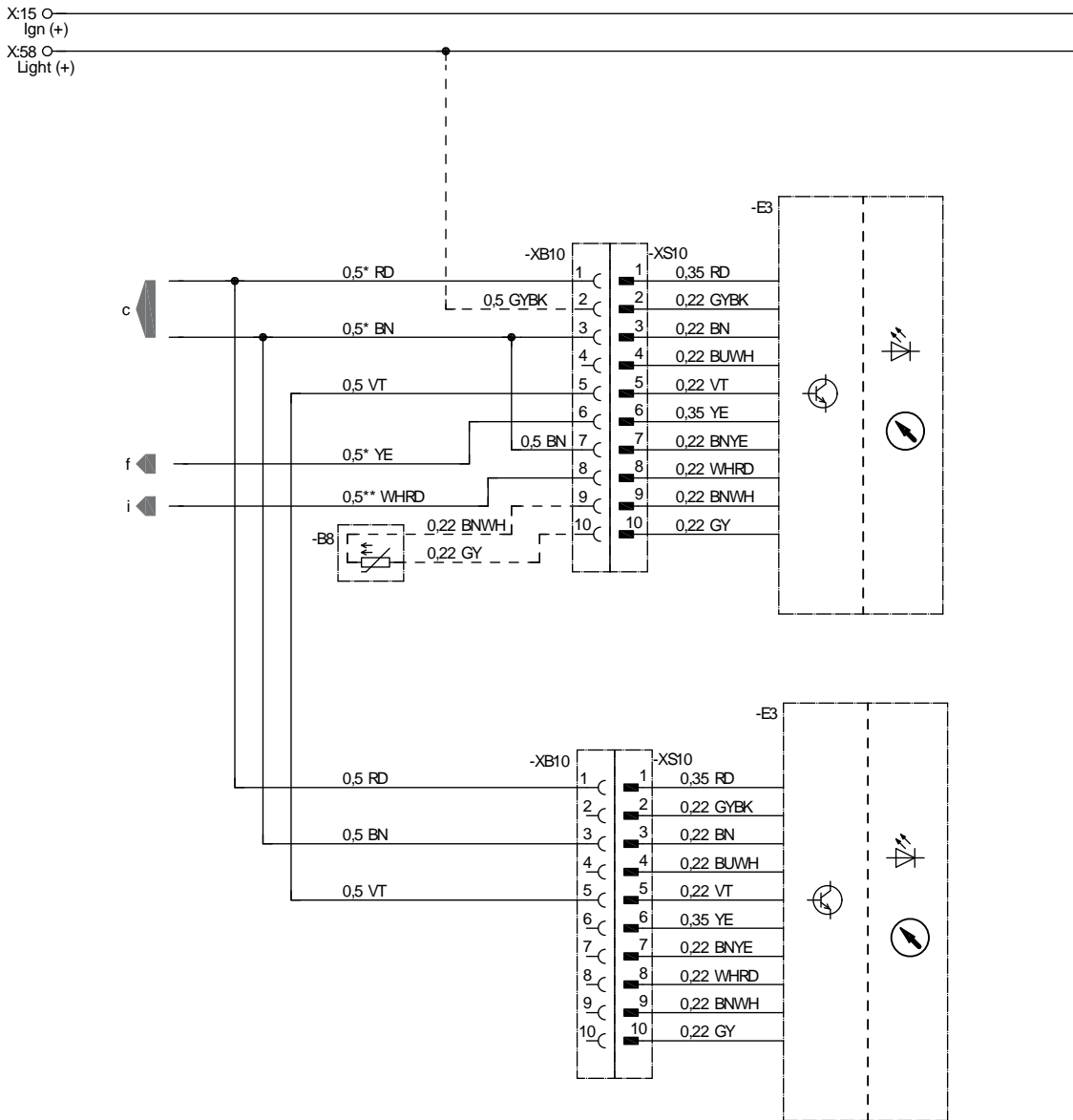

\* Hydronic MII 0,75 / Hydronic L 1,0  
\*\* Hydronic MII 1,5

22 1000 34 97 57

- B8 Sensor, interior temperature
- E3 EasyStart Timer
- c to the heater
- f Switch-on signal S+
- i ADR feedback from the heater

### CABLE COLOURS

RD	red	GY	grey	BK	black
BU	blue	YE	yellow	GN	green
WH	white	VT	violet	BN	brown

## 5 CIRCUIT DIAGRAM

### ADR MODE, COMBINATION OF EASYSTART TIMER WITH EASYSTART TIMER

Hydronic II C, Hydronic M II

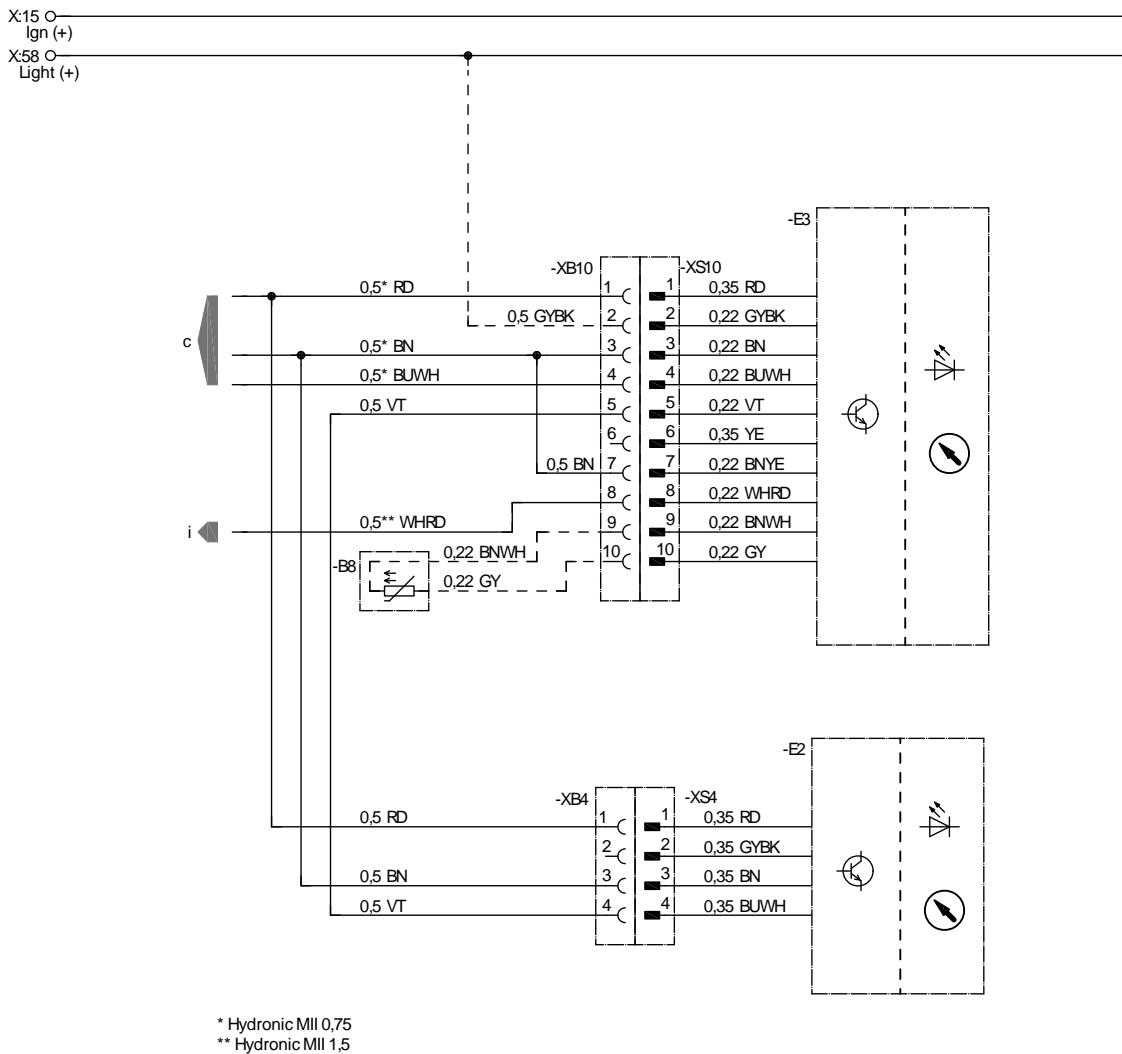

22 1000 34 97 65

- B8 Sensor, interior temperature
- E3 EasyStart Timer
- c to the heater
- i ADR feedback from the heater

#### CABLE COLOURS

RD	red	GY	grey	BK	black
BU	blue	YE	yellow	GN	green
WH	white	VT	violet	BN	brown

## 5 CIRCUIT DIAGRAM

### ADR MODE, COMBINATION OF EASYSTART TIMER WITH EASYSTART TIMER

Airtronic, Airtronic M, Airtronic L

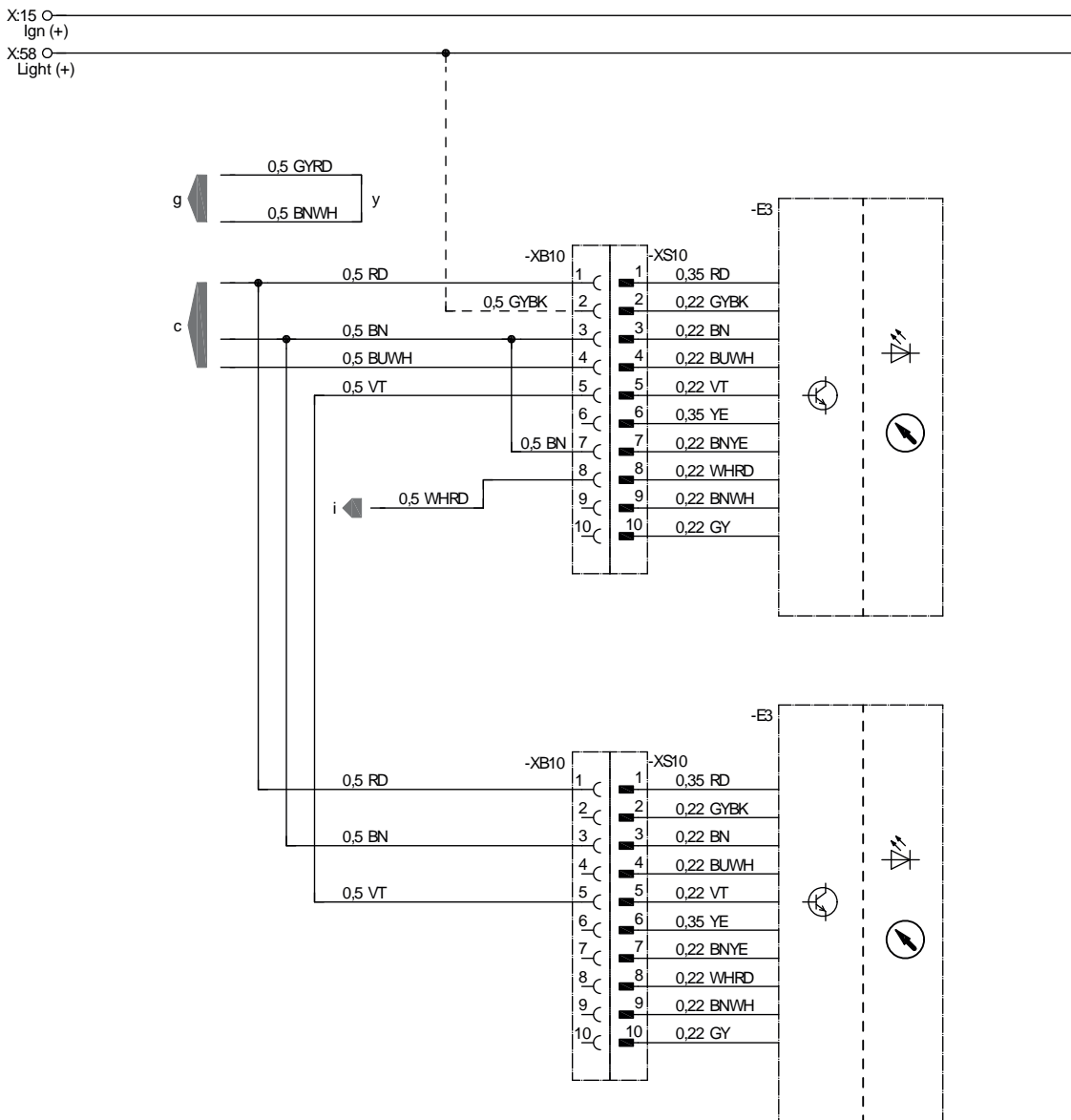

22 1000 34 97 67

- E3 EasyStart Timer
- c to the heater
- g to the heater
- i ADR feedback from the heater
- y Connect cables and insulate

#### CABLE COLOURS

RD	red	GY	grey	BK	black
BU	blue	YE	yellow	GN	green
WH	white	VT	violet	BN	brown

## 5 CIRCUIT DIAGRAM

**ADR MODE, COMBINATION OF EASYSTART TIMER WITH EASYSTART SELECT AND CONNECTION VIA SWITCH-ON SIGNAL S+**  
Hydronic 24 volt, Hydronic II C, Hydronic M II

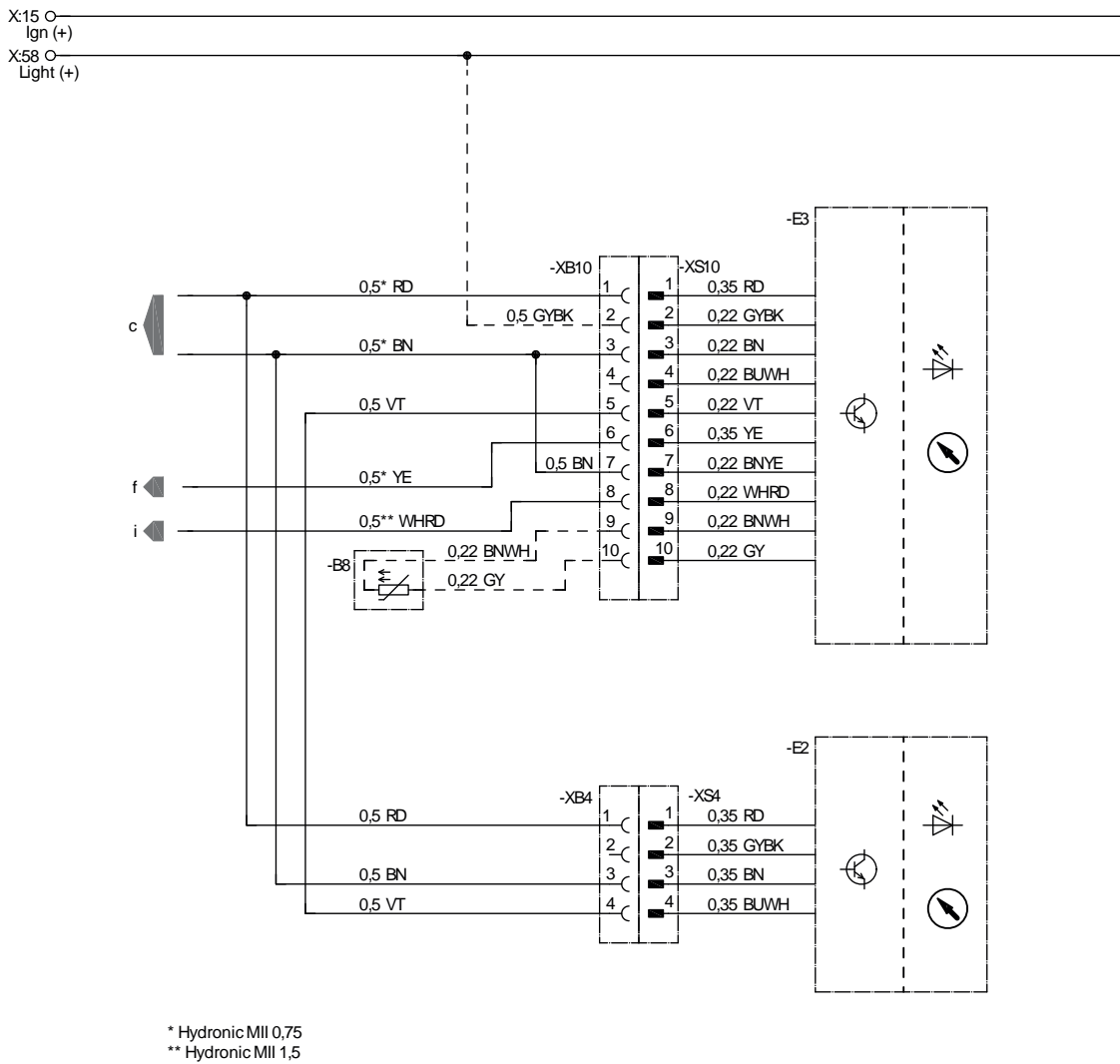

22 1000 34 97 58

- B8 Sensor, interior temperature
- E2 EasyStart Select control unit
- E3 EasyStart Timer
- c to the heater
- f Switch-on signal S+
- i ADR feedback from the heater

### CABLE COLOURS

RD	red	GY	grey	BK	black
BU	blue	YE	yellow	GN	green
WH	white	VT	violet	BN	brown

# 5 CIRCUIT DIAGRAM

## ADR MODE, COMBINATION OF EASYSTART TIMER WITH EASYSTART SELECT

Hydronic II C, Hydronic M II

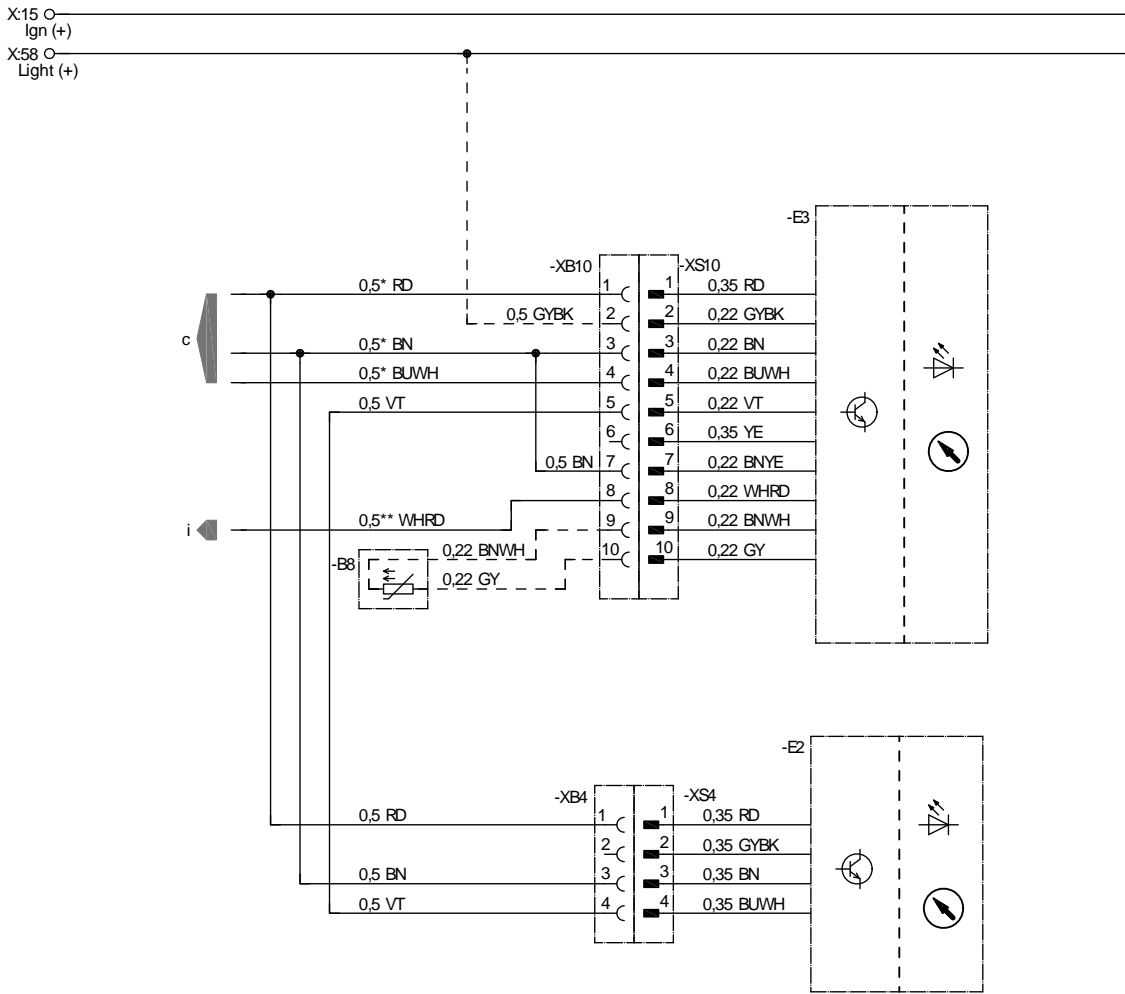

\* Hydronic MII 0,75  
 \*\* Hydronic MII 1,5

22 1000 34 97 66

- B8 Sensor, interior temperature
- E2 EasyStart Select control unit
- E3 EasyStart Timer
- c to the heater
- i ADR feedback from the heater

### CABLE COLOURS

RD	red	GY	grey	BK	black
BU	blue	YE	yellow	GN	green
WH	white	VT	violet	BN	brown

## 5 CIRCUIT DIAGRAM

### ADR MODE, COMBINATION OF EASYSTART TIMER WITH EASYSTART SELECT

Airtronic, Airtronic M, Airtronic L

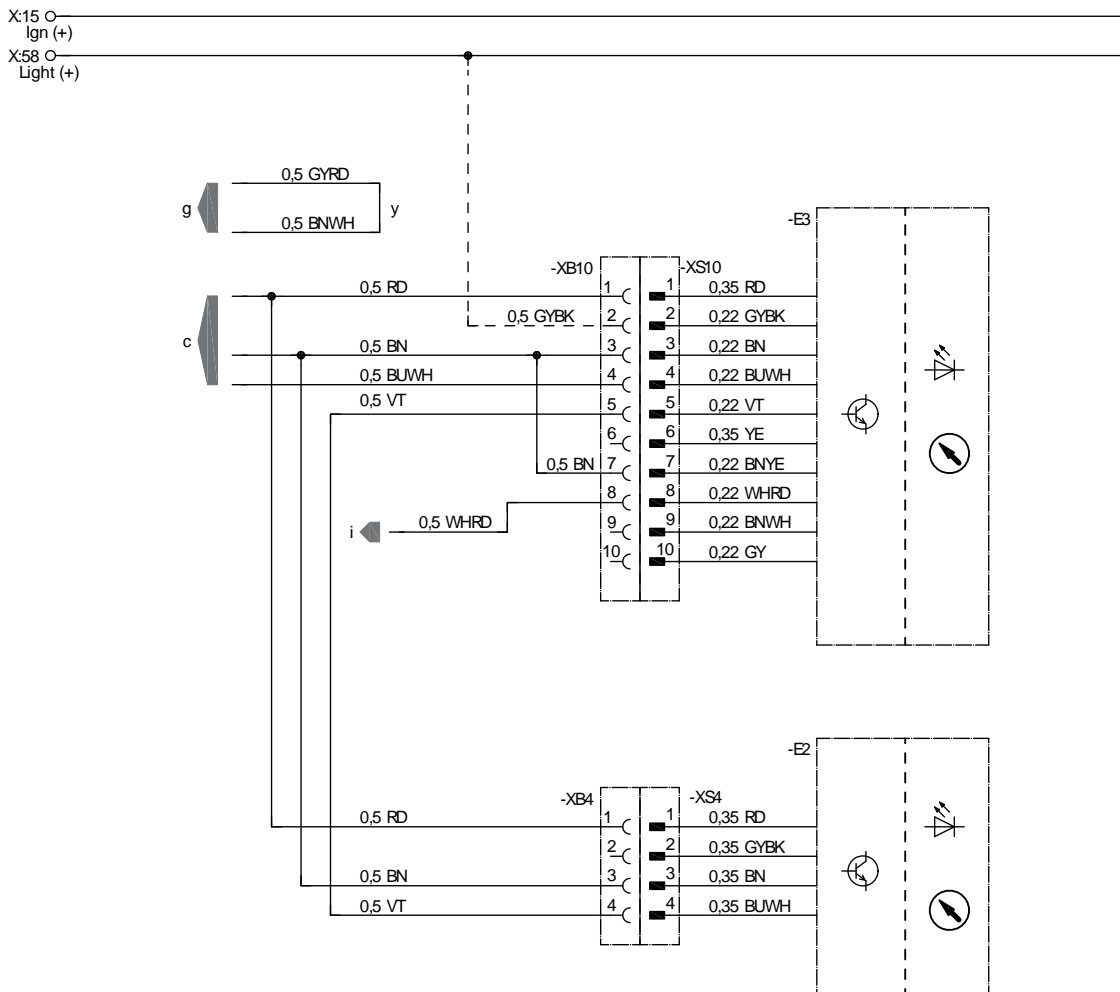

22 1000 34 97 68

- E2 EasyStart Select control unit
- E3 EasyStart Timer
- c to the heater
- g to the heater
- i ADR feedback from the heater
- y Connect cables and insulate

#### CABLE COLOURS

RD	red	GY	grey	BK	black
BU	blue	YE	yellow	GN	green
WH	white	VT	violet	BN	brown



## 5 CIRCUIT DIAGRAM

### OVERVIEW OF THE CIRCUIT DIAGRAMS

#### EASYSTART REMOTE+

REMOTE+ →	1 HEATER	
	Hydronic, Hydronic II, Hydronic II C, Hydronic II Comfort, Hydronic M II	66
	Airtronic, Airtronic M, Airtronic L	67
	Airtronic, Airtronic M, Airtronic L with external control temperature sensor, interior	68
	Hydronic, Hydronic II, Hydronic II C, Hydronic II Comfort, Hydronic M II, Hydronic L II via switch-on signal S+	69
	Hydronic auxiliary heater	70
	Hydronic auxiliary heater via upgrade box	71

REMOTE+ →	2 HEATERS	
	Hydronic, Hydronic II, Hydronic II C, Hydronic II Comfort, Hydronic M II (diagnostics cable)	
	Airtronic, Airtronic M, Airtronic L (diagnostics cable)	72
	Hydronic, Hydronic II, Hydronic II C, Hydronic II Comfort, Hydronic M II (diagnostics cable)	
	Hydronic, Hydronic II, Hydronic II C, Hydronic II Comfort, Hydronic M II, Hydronic L II (switch-on signal S+)	73
	Hydronic, Hydronic II, Hydronic II C, Hydronic II Comfort, Hydronic M II (diagnostics cable)	
	and Hydronic, Hydronic II, Hydronic II C, Hydronic II Comfort, Hydronic M II (diagnostics cable)	74
	Airtronic, Airtronic M, Airtronic L (diagnostics cable)	
	Airtronic, Airtronic M, Airtronic L (diagnostics cable)	75
	Airtronic, Airtronic M, Airtronic L (diagnostics cable)	
	Hydronic, Hydronic II, Hydronic II C, Hydronic II Comfort, Hydronic M II, Hydronic L II (switch-on signal S+)	76

#### COMBINED CONTROL UNITS

REMOTE+ / TIMER →	1 HEATER	
	Hydronic, Hydronic II, Hydronic II C, Hydronic II Comfort, Hydronic M II	77
	Airtronic, Airtronic M, Airtronic L	78
	Hydronic, Hydronic II, Hydronic II C, Hydronic II Comfort, Hydronic M II, Hydronic L II via switch-on signal S+	79

REMOTE+ / SELECT		
	Hydronic, Hydronic II, Hydronic II C, Hydronic II Comfort, Hydronic M II	80
	Airtronic, Airtronic M, Airtronic L	81
	Hydronic, Hydronic II, Hydronic II C, Hydronic II Comfort, Hydronic M II, Hydronic L II via switch-on signal S+	82

#### COMBINED CONTROL UNITS

REMOTE+ / TIMER →	2 HEATERS	
	Airtronic, Airtronic M, Airtronic L (diagnostics cable)	
	Hydronic, Hydronic II, Hydronic II C, Hydronic II Comfort, Hydronic M II, Hydronic L II (switch-on signal S+)	83

#### SPECIAL FUNCTION

REMOTE+ →	1 HEATER WITH ROOM TEMPERATURE CONTROL	
	Hydronic, Hydronic II, Hydronic II C, Hydronic II Comfort, Hydronic M II	84

## 5 CIRCUIT DIAGRAM

### EASYSTART REMOTE+ CONNECTION

Hydronic, Hydronic II, Hydronic II C, Hydronic II Comfort, Hydronic M II

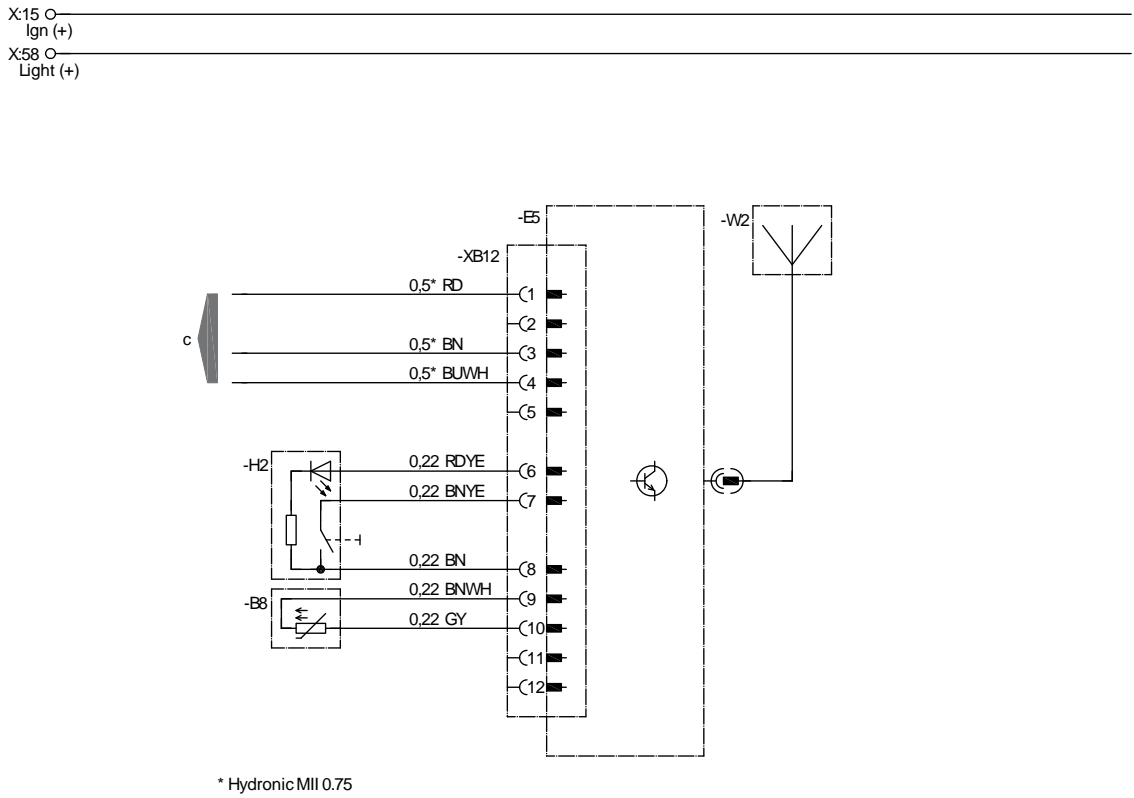

22 1000 34 97 22

- B8 Sensor, interior temperature
- E5 EasyStart Remote+ remote control
- H2 EasyStart Remote / Remote+ button
- W2 EasyStart Remote / Remote+ antenna
- c to the heater

#### CABLE COLOURS

RD	red	GY	grey	BK	black
BU	blue	YE	yellow	GN	green
WH	white	VT	violet	BN	brown

## 5 CIRCUIT DIAGRAM

### EASYSTART REMOTE+ CONNECTION

Airtronic, Airtronic M, Airtronic L

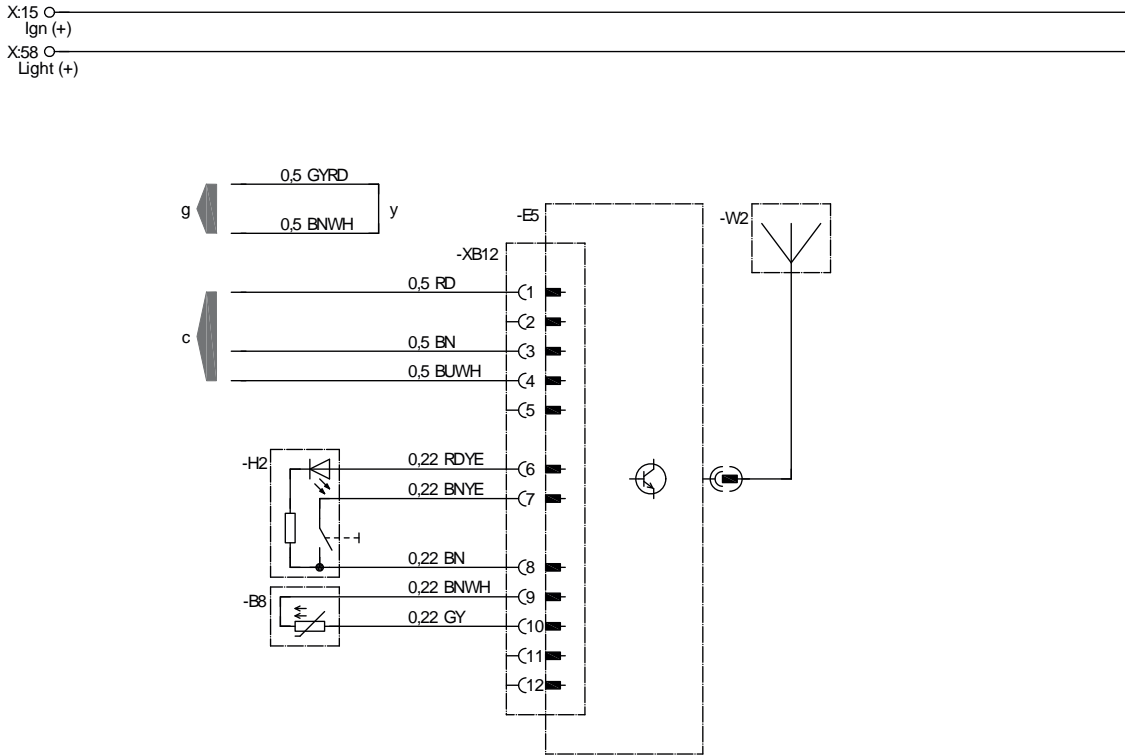

22 1000 34 97 29

- B8 Sensor, interior temperature
- E5 EasyStart Remote+ remote control
- H2 EasyStart Remote / Remote+ button
- W2 EasyStart Remote / Remote+ antenna
- c to the heater
- g to the heater
- y Connect cables and insulate

#### CABLE COLOURS

RD	red	GY	grey	BK	black
BU	blue	YE	yellow	GN	green
WH	white	VT	violet	BN	brown

## 5 CIRCUIT DIAGRAM

### EASystART REMOTE+ CONNECTION

Airtronic, Airtronic M, Airtronic L with external control temperature sensor, interior

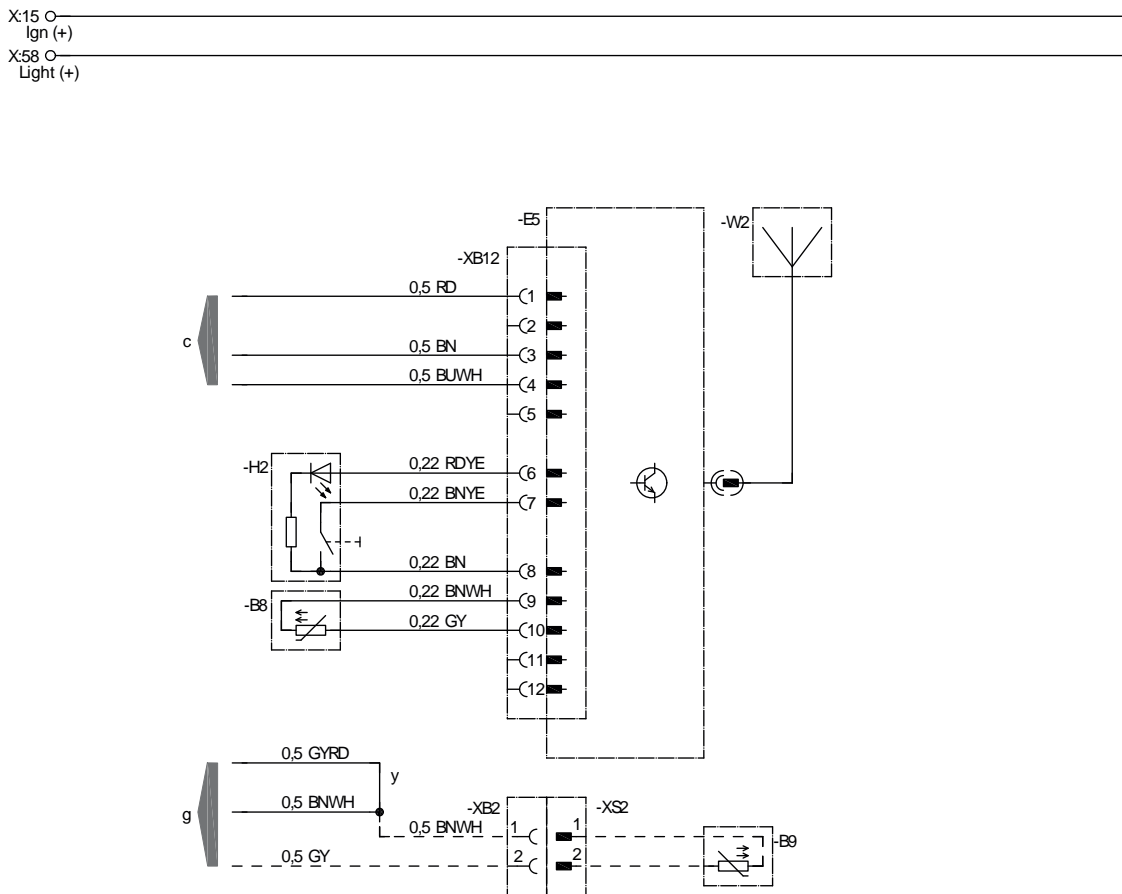

22 1000 34 97 73

- B8 Sensor, interior temperature
- B9 External control temperature sensor, interior
- E5 EasyStart Remote+ remote control
- H2 EasyStart Remote / Remote+ button
- W2 EasyStart Remote / Remote+ antenna
- c to the heater
- g to the heater
- y Connect cables and insulate

#### CABLE COLOURS

RD	red	GY	grey	BK	black
BU	blue	YE	yellow	GN	green
WH	white	VT	violet	BN	brown

## 5 CIRCUIT DIAGRAM

### EASYSTART REMOTE+ CONNECTION VIA SWITCH-ON SIGNAL S+

Hydronic, Hydronic II, Hydronic II C, Hydronic II Comfort, Hydronic M II, Hydronic L II

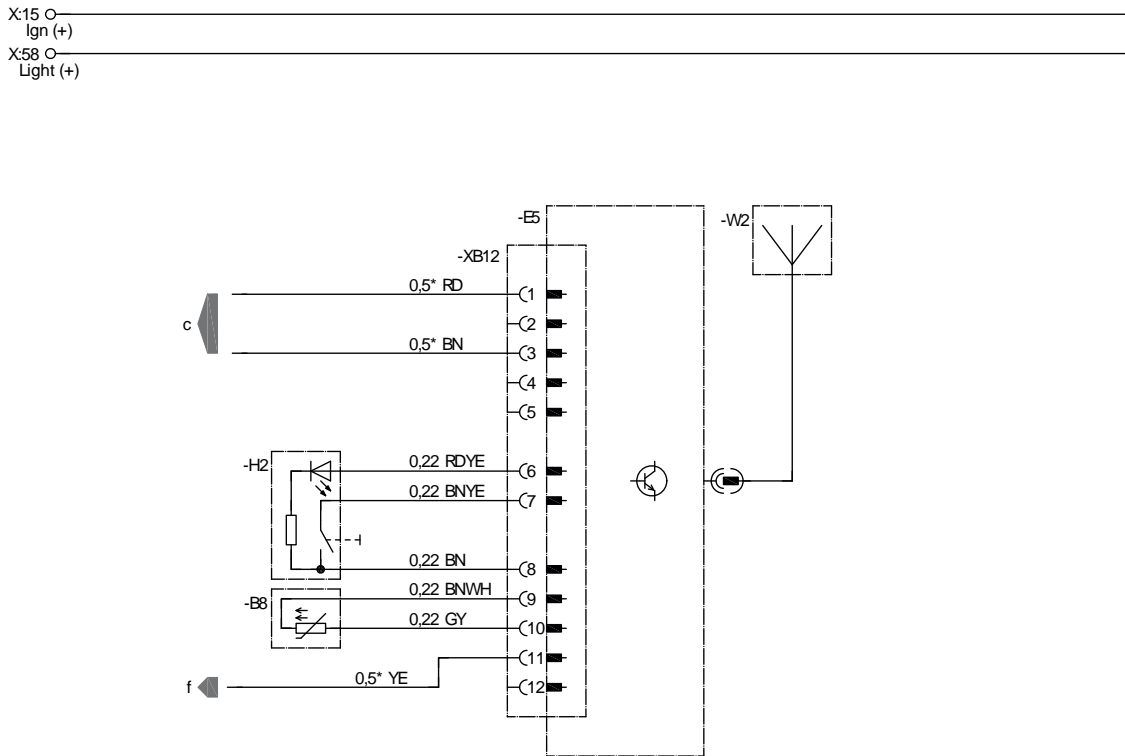

\* Hydronic MII 0,75 / Hydronic L 1,0

22 1000 34 97 26

- B8 Sensor, interior temperature
- E5 EasyStart Remote+ remote control
- H2 EasyStart Remote / Remote+ button
- W2 EasyStart Remote / Remote+ antenna
- c to the heater
- f Switch-on signal S+

#### CABLE COLOURS

RD	red	GY	grey	BK	black
BU	blue	YE	yellow	GN	green
WH	white	VT	violet	BN	brown

## 5 CIRCUIT DIAGRAM

### EASystART REMOTE+ CONNECTION

Hydronic auxiliary heater

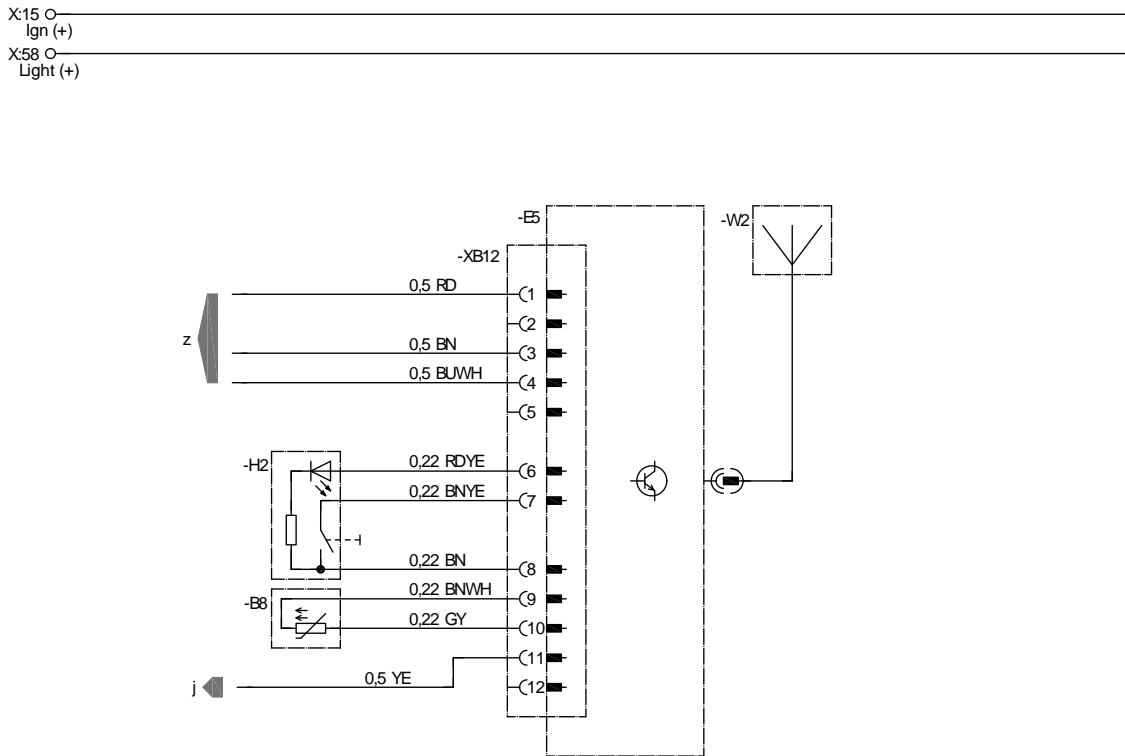

22 1000 34 97 59

- B8 Sensor, interior temperature
- E5 EasyStart Remote+ remote control
- H2 EasyStart Remote / Remote+ button
- W2 EasyStart Remote / Remote+ antenna
- z to the auxiliary heater
- j to the relay for connection of water pump and vehicle fan (max. 500 mA)

#### CABLE COLOURS

RD	red	GY	grey	BK	black
BU	blue	YE	yellow	GN	green
WH	white	VT	violet	BN	brown

## 5 CIRCUIT DIAGRAM

### EASystART REMOTE+ CONNECTION

Hydronic auxiliary heater with upgrade box

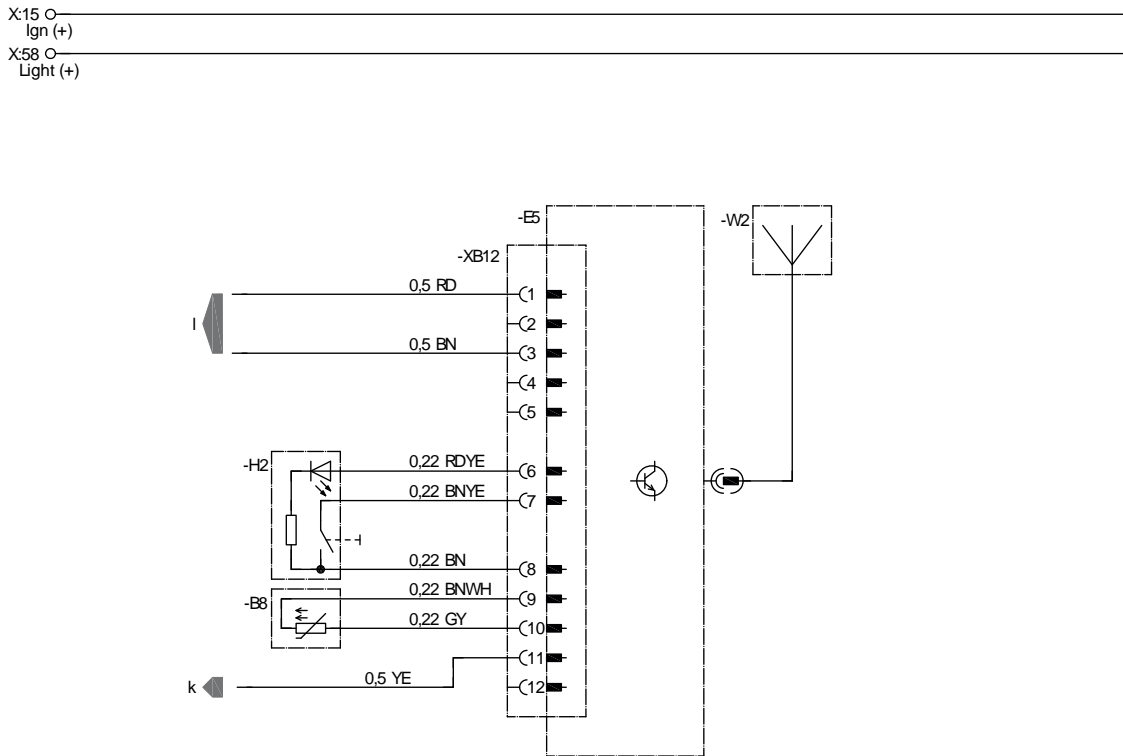

22 1000 34 97 60

- B8 Sensor, interior temperature
- E5 EasyStart Remote+ remote control
- H2 EasyStart Remote / Remote+ button
- W2 EasyStart Remote / Remote+ antenna
- k to the upgrade box or relay circuit for water pump and vehicle fan connection (max. 500 mA)
- I to the upgrade box

#### CABLE COLOURS

RD	red	GY	grey	BK	black
BU	blue	YE	yellow	GN	green
WH	white	VT	violet	BN	brown

## 5 CIRCUIT DIAGRAM

### EASYSTART REMOTE+ CONNECTION

1st heater via the diagnostics cable

Hydronic, Hydronic II, Hydronic II C, Hydronic II Comfort, Hydronic M II

2nd heater via the diagnostics cable

Airtronic, Airtronic M, Airtronic L

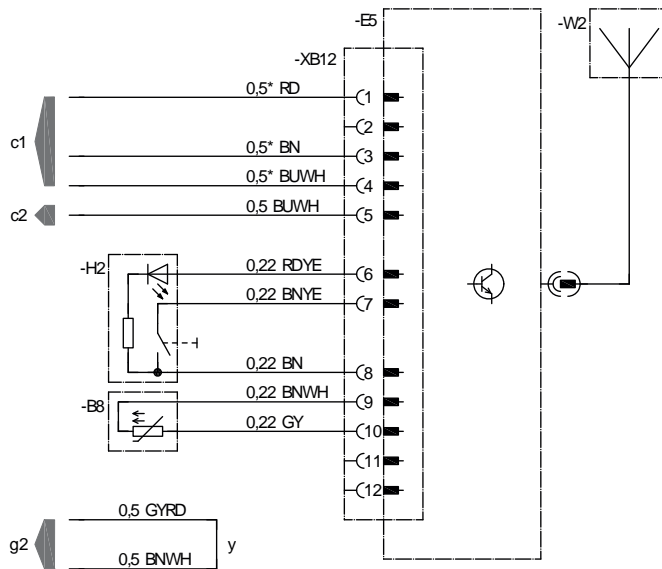
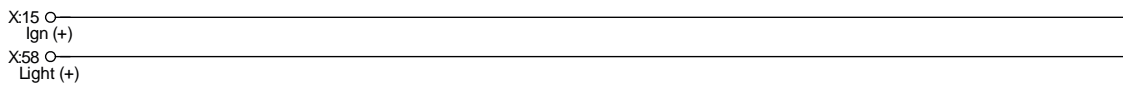

\* Hydronic MII 0.75

22 1000 34 97 23

- B8 Sensor, interior temperature
- E5 EasyStart Remote+ remote control
- H2 EasyStart Remote / Remote+ button
- W2 EasyStart Remote / Remote+ antenna
- c1 to heater 1
- c2 to heater 2
- g2 to heater 2
- y Connect cables and insulate

#### CABLE COLOURS

RD	red	GY	grey	BK	black
BU	blue	YE	yellow	GN	green
WH	white	VT	violet	BN	brown



## 5 CIRCUIT DIAGRAM

### EASYSTART REMOTE+ CONNECTION

1st heater via the diagnostics cable

Hydronic, Hydronic II, Hydronic II C, Hydronic II Comfort, Hydronic M II

2nd heater via switch-on signal S+

Hydronic, Hydronic II, Hydronic II C, Hydronic II Comfort, Hydronic M II, Hydronic L II

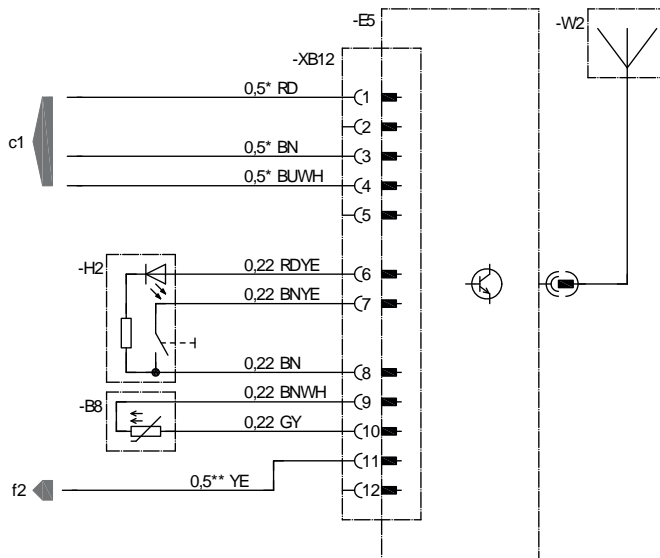
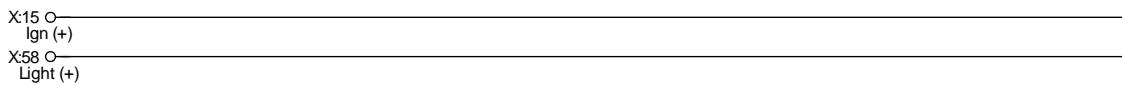

\* Hydronic MII 0,75  
\*\* Hydronic MII 0,75 / Hydronic L 1,0

22 1000 34 97 25

- B8 Sensor, interior temperature
- E5 EasyStart Remote+ remote control
- H2 EasyStart Remote / Remote+ button
- W2 EasyStart Remote / Remote+ antenna
- c1 to heater 1
- f2 Switch-on signal S+, heater 2

#### CABLE COLOURS

RD	red	GY	grey	BK	black
BU	blue	YE	yellow	GN	green
WH	white	VT	violet	BN	brown

## 5 CIRCUIT DIAGRAM

### EASystART REMOTE+ CONNECTION

1st heater via the diagnostics cable

Hydronic, Hydronic II, Hydronic II C, Hydronic II Comfort, Hydronic M II

2nd heater via the diagnostics cable

Hydronic, Hydronic II, Hydronic II C, Hydronic II Comfort, Hydronic M II

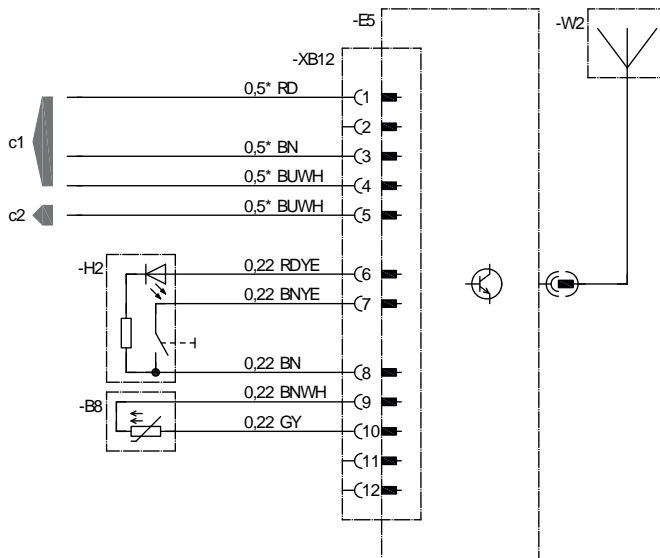
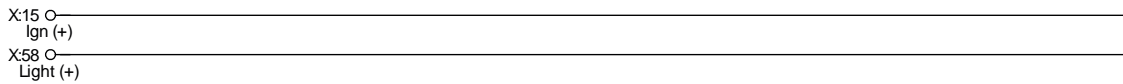

\* Hydronic MII 0.75

22 1000 34 97 24

- B8 Sensor, interior temperature
- E5 EasyStart Remote+ remote control
- H2 EasyStart Remote / Remote+ button
- W2 EasyStart Remote / Remote+ antenna
- c1 to heater 1
- c2 to heater 2

#### CABLE COLOURS

RD	red	GY	grey	BK	black
BU	blue	YE	yellow	GN	green
WH	white	VT	violet	BN	brown

## 5 CIRCUIT DIAGRAM

### EASystART REMOTE+ CONNECTION

1st heater via the diagnostics cable

Airtronic, Airtronic M, Airtronic L

2nd heater via the diagnostics cable

Airtronic, Airtronic M, Airtronic L

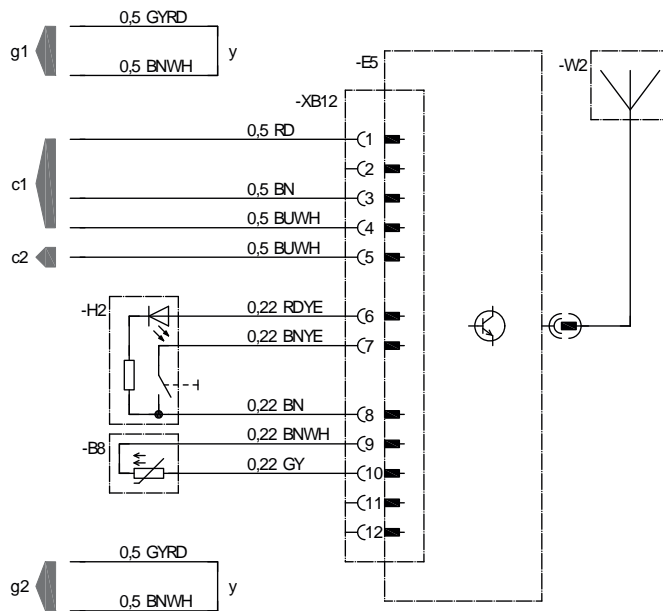
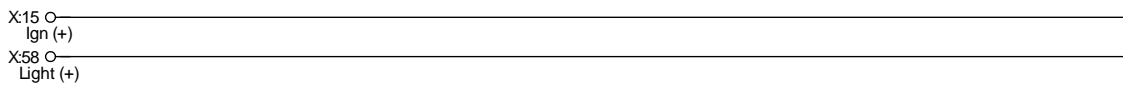

22 1000 34 97 31

- B8 Sensor, interior temperature
- E5 EasyStart Remote+ remote control
- H2 EasyStart Remote / Remote+ button
- W2 EasyStart Remote / Remote+ antenna
- c1 to heater 1
- c2 to heater 2
- g1 to heater 1
- g2 to heater 2
- y Connect cables and insulate

#### CABLE COLOURS

RD	red	GY	grey	BK	black
BU	blue	YE	yellow	GN	green
WH	white	VT	violet	BN	brown

## 5 CIRCUIT DIAGRAM

### EASYSTART REMOTE+ CONNECTION

1st heater via the diagnostics cable

Airtronic, Airtronic M, Airtronic L

2nd heater via switch-on signal S+

Hydronic, Hydronic II, Hydronic II C, Hydronic II Comfort, Hydronic M II, Hydronic L II

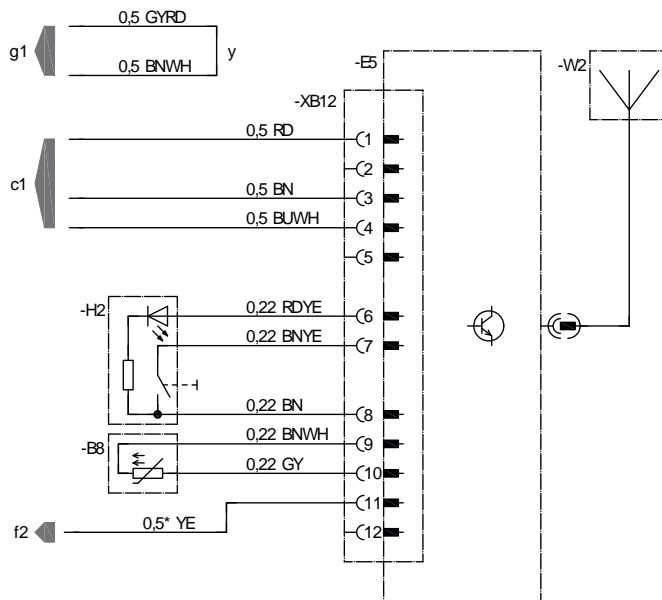
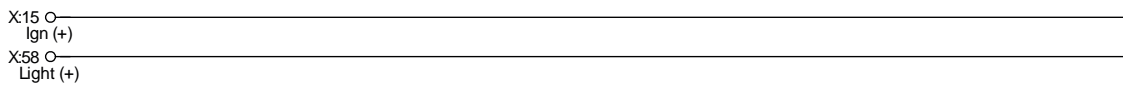

\* Hydronic MII 0.75 Hydronic L 1,0

22 1000 34 97 32

- B8 Sensor, interior temperature
- E5 EasyStart Remote+ remote control
- H2 EasyStart Remote / Remote+ button
- W2 EasyStart Remote / Remote+ antenna
- c1 to heater 1
- c2 to heater 2
- f2 Switch-on signal S+, heater 2
- y Connect cables and insulate

#### CABLE COLOURS

RD	red	GY	grey	BK	black
BU	blue	YE	yellow	GN	green
WH	white	VT	violet	BN	brown

## 5 CIRCUIT DIAGRAM

### EASYSTART REMOTE+ AND EASYSTART TIMER CONNECTION

Hydronic, Hydronic II, Hydronic II C, Hydronic II Comfort, Hydronic M II

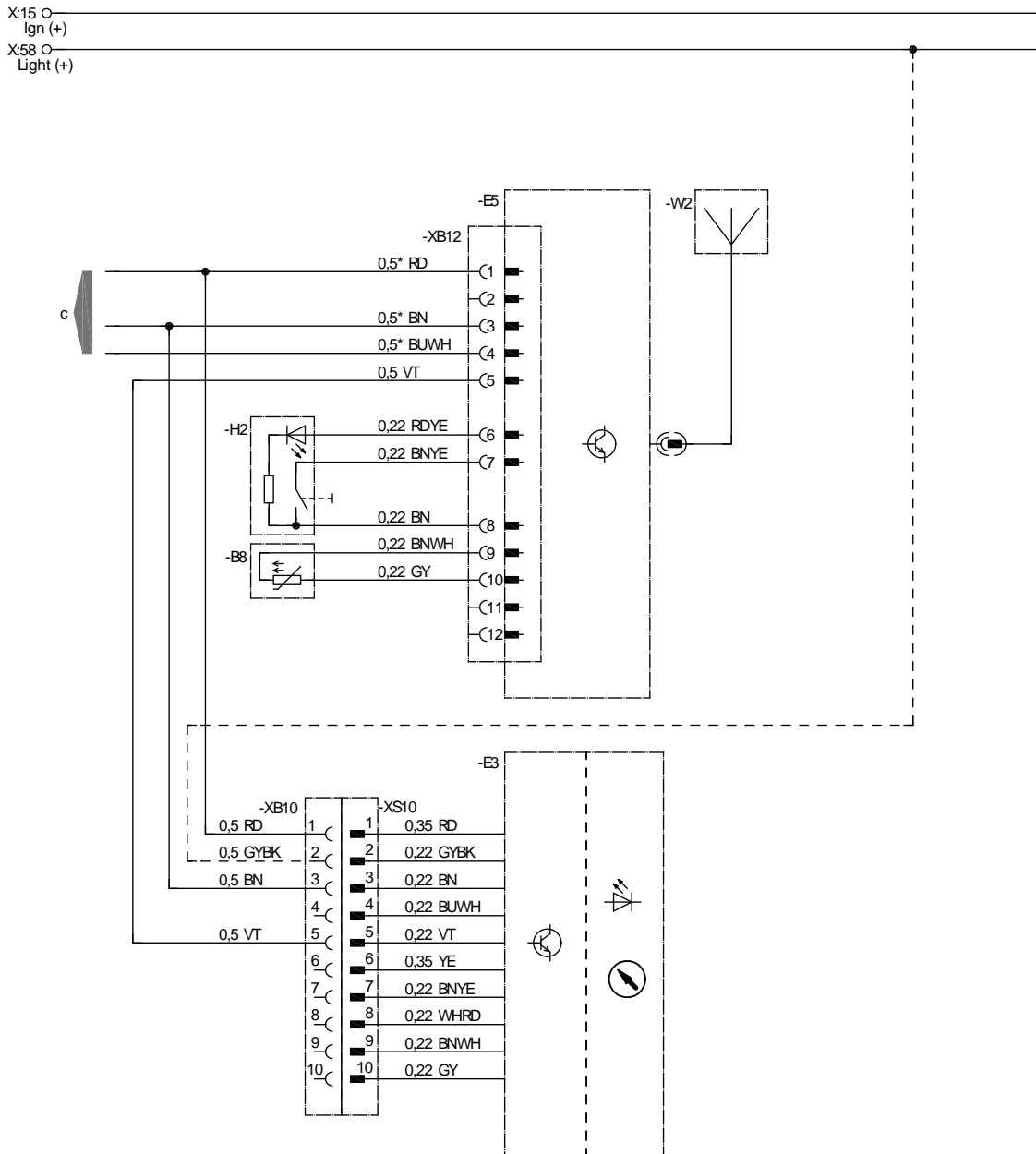

\* Hydronic MII 0.75

22 1000 34 97 28

- B8 Sensor, interior temperature
- E3 EasyStart Timer
- E5 EasyStart Remote+ remote control
- H2 EasyStart Remote / Remote+ button
- W2 EasyStart Remote / Remote+ antenna
- c to the heater

#### CABLE COLOURS

RD	red	GY	grey	BK	black
BU	blue	YE	yellow	GN	green
WH	white	VT	violet	BN	brown

## 5 CIRCUIT DIAGRAM

### EASYSTART REMOTE+ AND EASYSTART TIMER CONNECTION

Airtronic, Airtronic M, Airtronic L

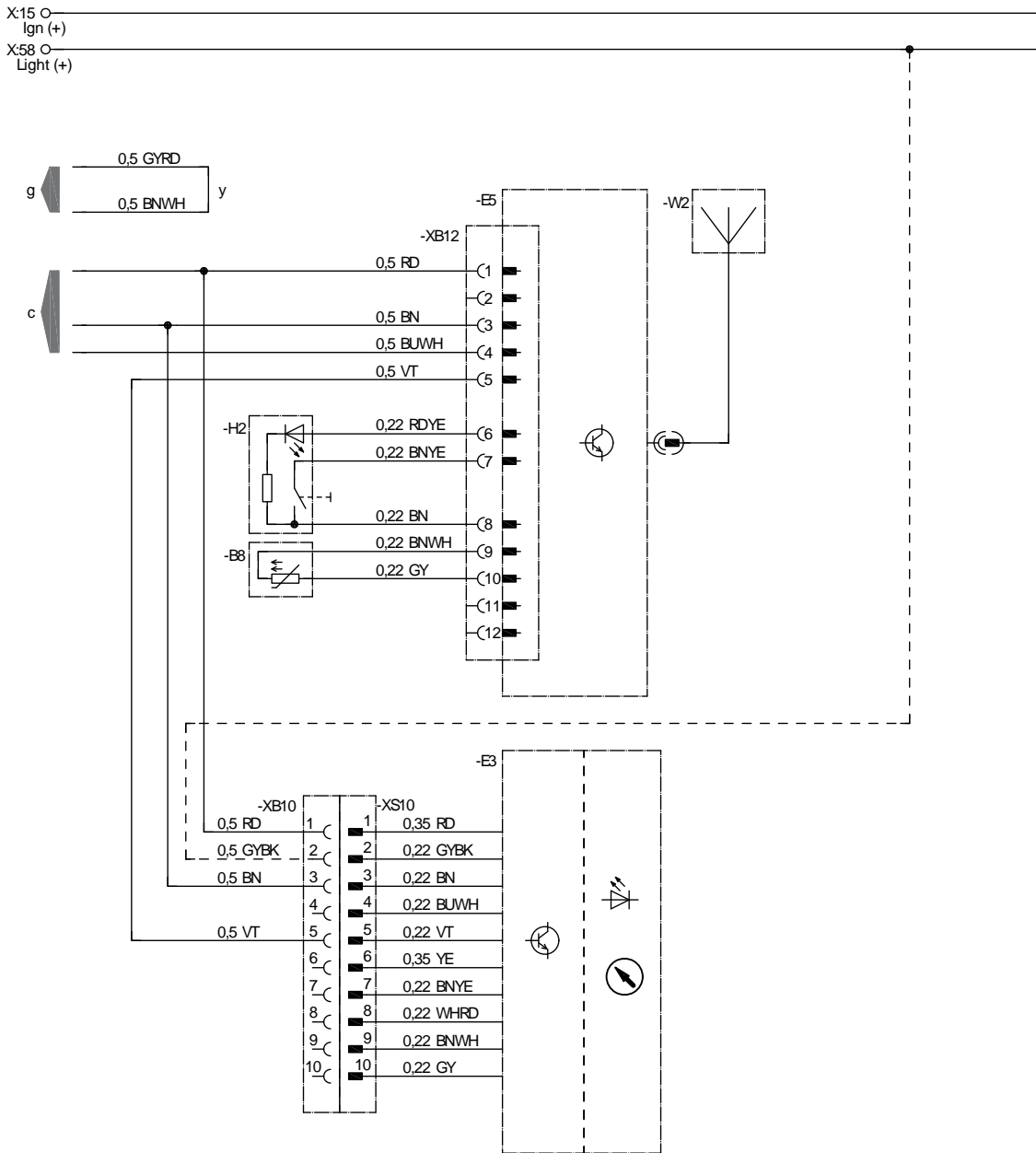

22 1000 34 97 30

- B8 Sensor, interior temperature
- E3 EasyStart Timer
- E5 EasyStart Remote+ remote control
- H2 EasyStart Remote / Remote+ button
- W2 EasyStart Remote / Remote+ antenna
- c to the heater
- y Connect cables and insulate

#### CABLE COLOURS

RD	red	GY	grey	BK	black
BU	blue	YE	yellow	GN	green
WH	white	VT	violet	BN	brown

## 5 CIRCUIT DIAGRAM

EASYSTART REMOTE+ AND EASYSTART TIMER CONNECTION VIA SWITCH-ON SIGNAL S+  
Hydronic, Hydronic II, Hydronic II C, Hydronic II Comfort, Hydronic M II, Hydronic L II

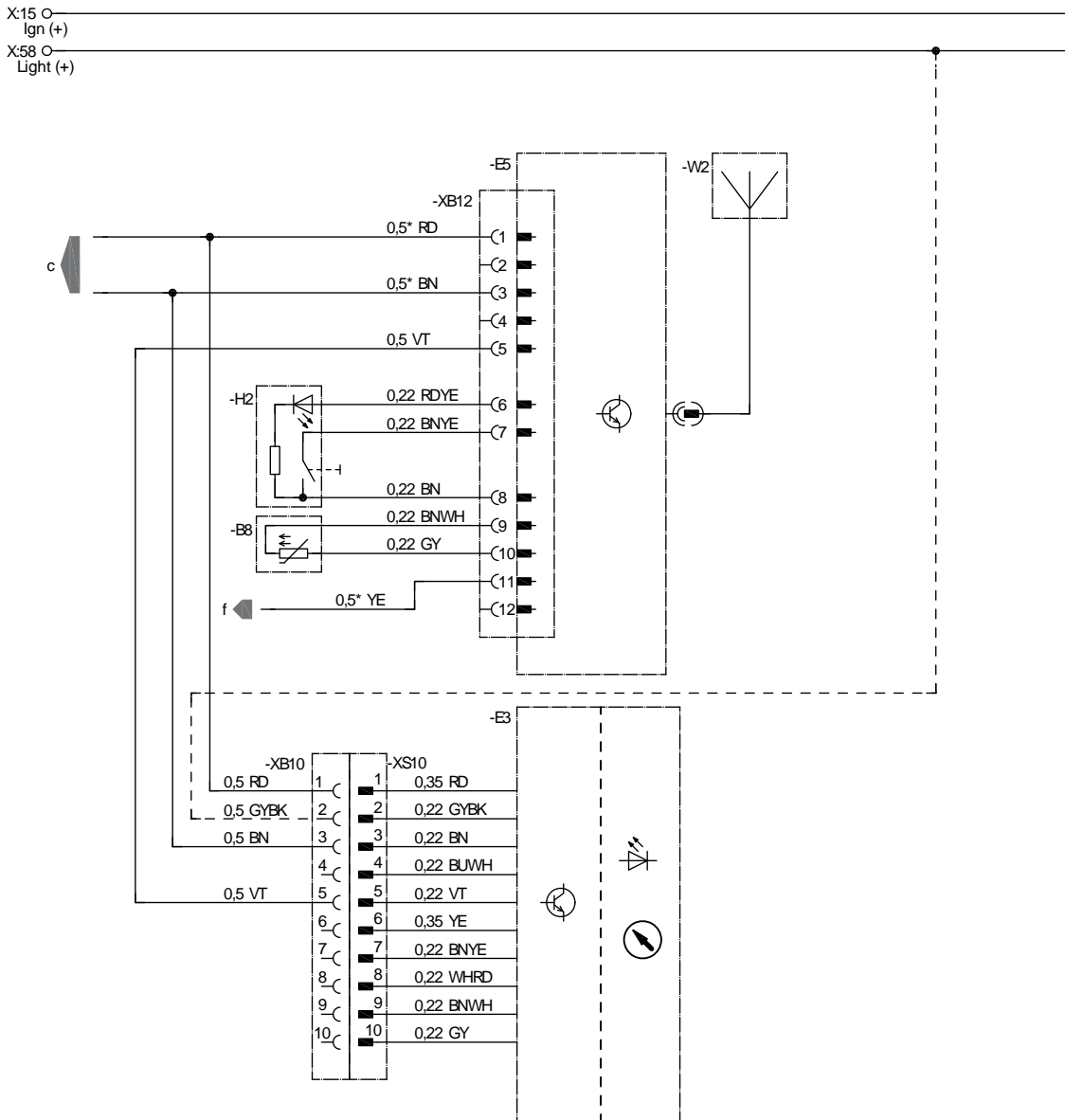

\*\* Hydronic MII 0,75 / Hydronic L 1,0

22 1000 34 97 62

- B8 Sensor, interior temperature
- E3 EasyStart Timer
- E5 EasyStart Remote+ remote control
- H2 EasyStart Remote / Remote+ button
- W2 EasyStart Remote / Remote+ antenna
- c to the heater
- f Switch-on signal S+

### CABLE COLOURS

RD	red	GY	grey	BK	black
BU	blue	YE	yellow	GN	green
WH	white	VT	violet	BN	brown

# 5 CIRCUIT DIAGRAM

## EASystart Remote+ AND EASystart Select CONNECTION Hydronic, Hydronic II, Hydronic II C, Hydronic II Comfort, Hydronic M II

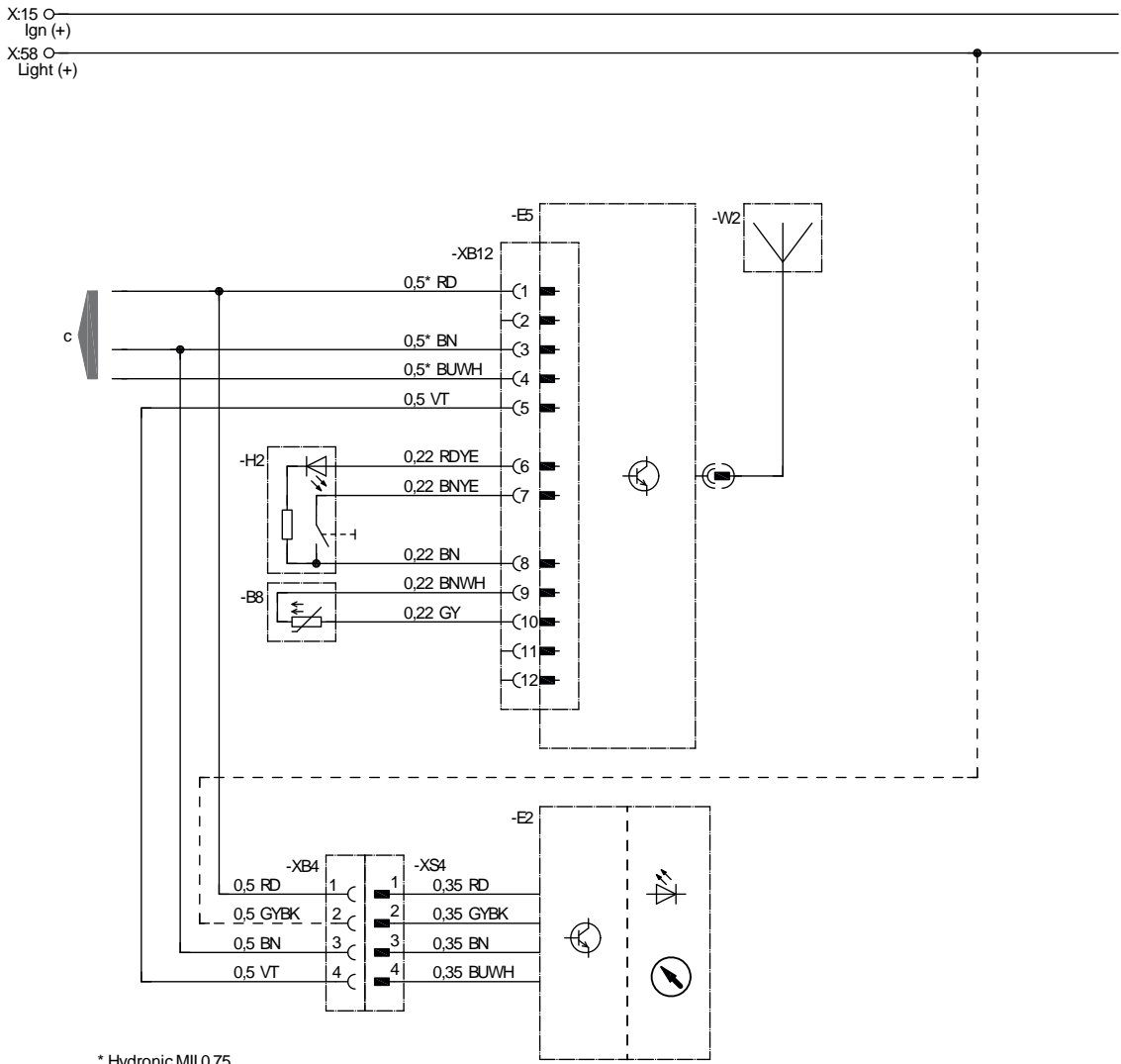

22 1000 34 97 54

- B8 Sensor, interior temperature
- E2 EasyStart Select control unit
- E5 EasyStart Remote+ remote control
- H2 EasyStart Remote / Remote+ button
- W2 EasyStart Remote / Remote+ antenna
- c to the heater

### CABLE COLOURS

RD	red	GY	grey	BK	black
BU	blue	YE	yellow	GN	green
WH	white	VT	violet	BN	brown



## 5 CIRCUIT DIAGRAM

### EASYSTART REMOTE+ AND EASYSTART SELECT CONNECTION

Airtronic, Airtronic M, Airtronic L

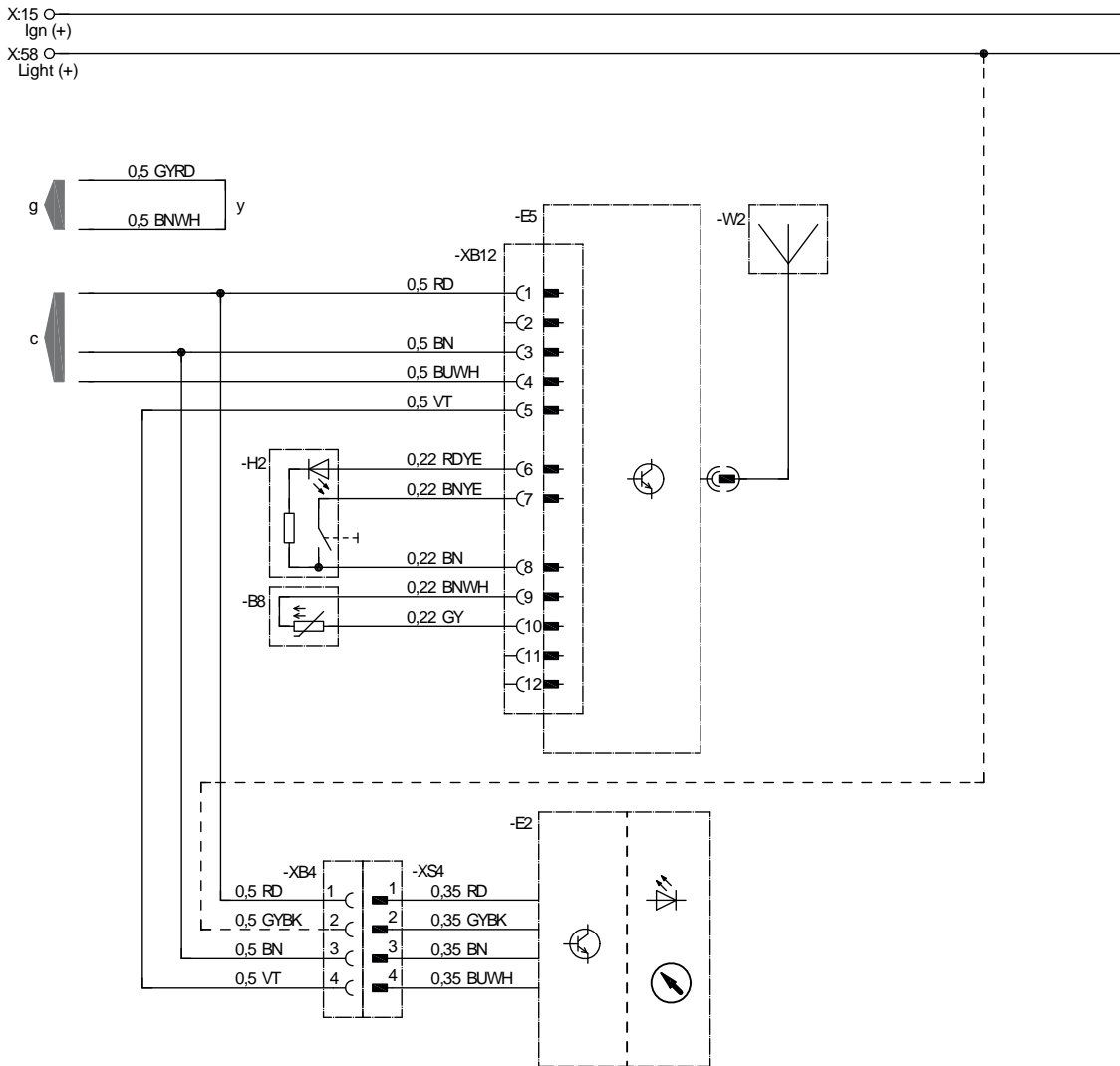

22 1000 34 97 56

- B8 Sensor, interior temperature
- E2 EasyStart Select control unit
- E5 EasyStart Remote+ remote control
- H2 EasyStart Remote / Remote+ button
- W2 EasyStart Remote / Remote+ antenna
- c to the heater
- y Connect cables and insulate

#### CABLE COLOURS

RD	red	GY	grey	BK	black
BU	blue	YE	yellow	GN	green
WH	white	VT	violet	BN	brown

## 5 CIRCUIT DIAGRAM

EASYSTART REMOTE+ AND EASYSTART SELECT CONNECTION VIA SWITCH-ON SIGNAL S+  
Hydronic, Hydronic II, Hydronic II C, Hydronic II Comfort, Hydronic M II, Hydronic L II

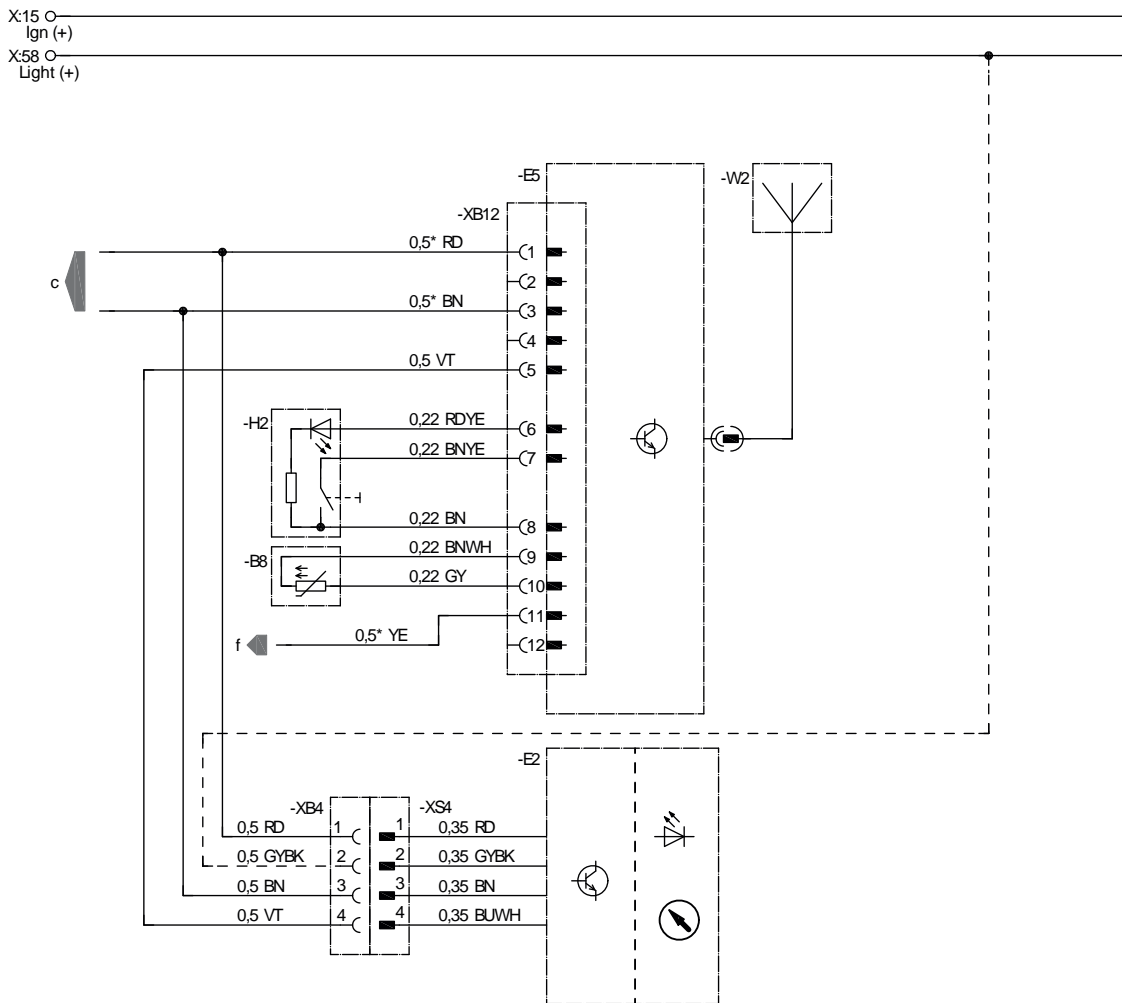

\*\* Hydronic MII 0,75 / Hydronic L 1,0

22 1000 34 97 63

- B8 Sensor, interior temperature
- E2 EasyStart Select control unit
- E5 EasyStart Remote+ remote control
- H2 EasyStart Remote / Remote+ button
- W2 EasyStart Remote / Remote+ antenna
- c to the heater

### CABLE COLOURS

RD	red	GY	grey	BK	black
BU	blue	YE	yellow	GN	green
WH	white	VT	violet	BN	brown

## 5 CIRCUIT DIAGRAM

### EASYSTART REMOTE+ AND EASYSTART TIMER CONNECTION

1st heater via the diagnostics cable

Airtronic, Airtronic M, Airtronic L

2nd heater via switch-on signal S+

Hydronic, Hydronic II, Hydronic II C, Hydronic II Comfort, Hydronic M II, Hydronic L II

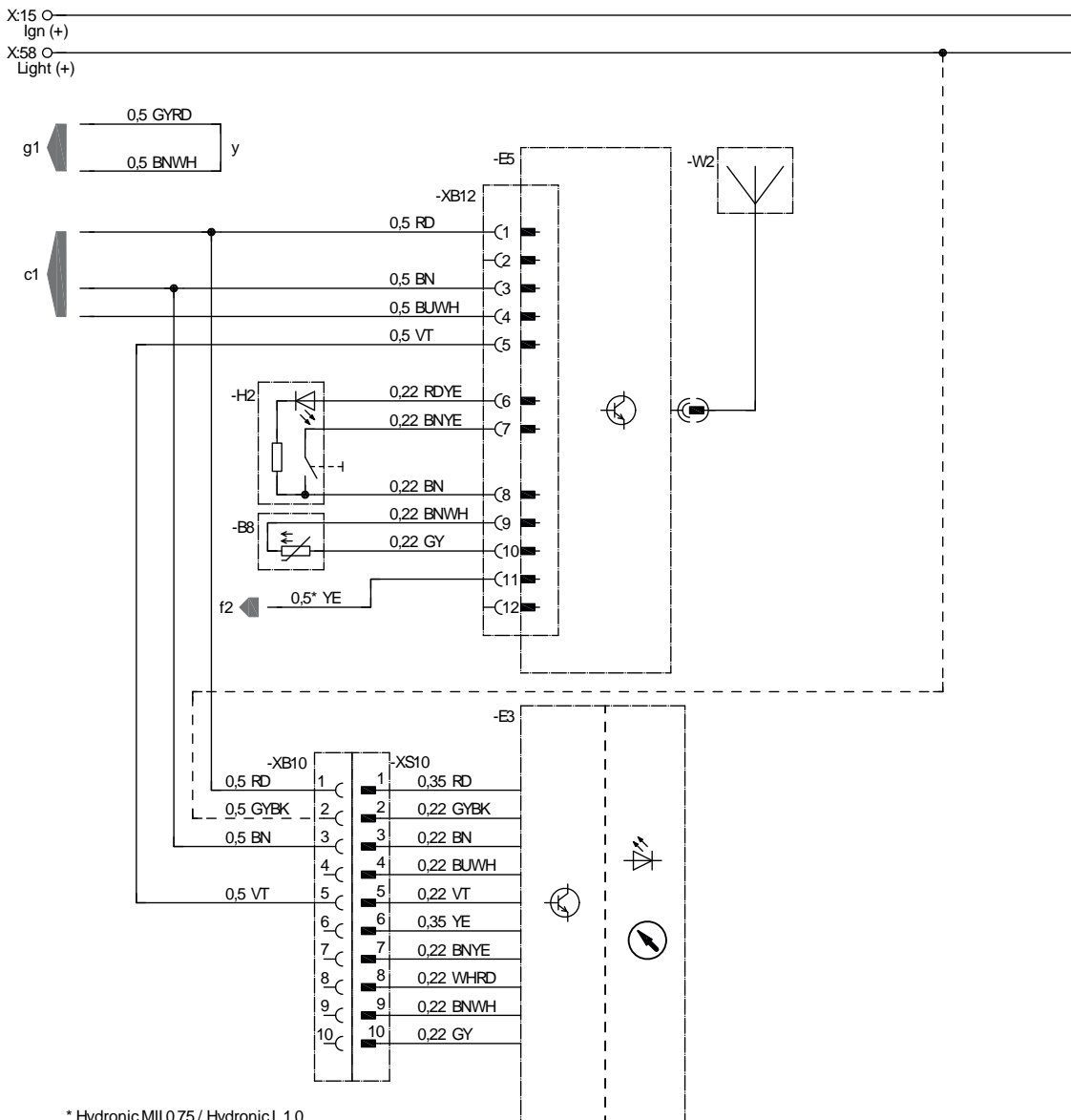

\* Hydronic MII 0.75 / Hydronic L 1.0

22 1000 34 97 64

- B8 Sensor, interior temperature
- E3 EasyStart Timer
- E5 EasyStart Remote+ remote control
- H2 EasyStart Remote / Remote+ button
- W2 EasyStart Remote / Remote+ antenna
- c1 to heater 1
- f2 Switch-on signal S+, heater 2

- g1 to heater 1
- y Connect cables and insulate

#### CABLE COLOURS

RD	red	GY	grey	BK	black
BU	blue	YE	yellow	GN	green
WH	white	VT	violet	BN	brown

## 5 CIRCUIT DIAGRAM

### EASYSTART REMOTE+ CONNECTION WITH ROOM TEMPERATURE CONTROL Hydronic, Hydronic II, Hydronic II C, Hydronic II Comfort, Hydronic M II

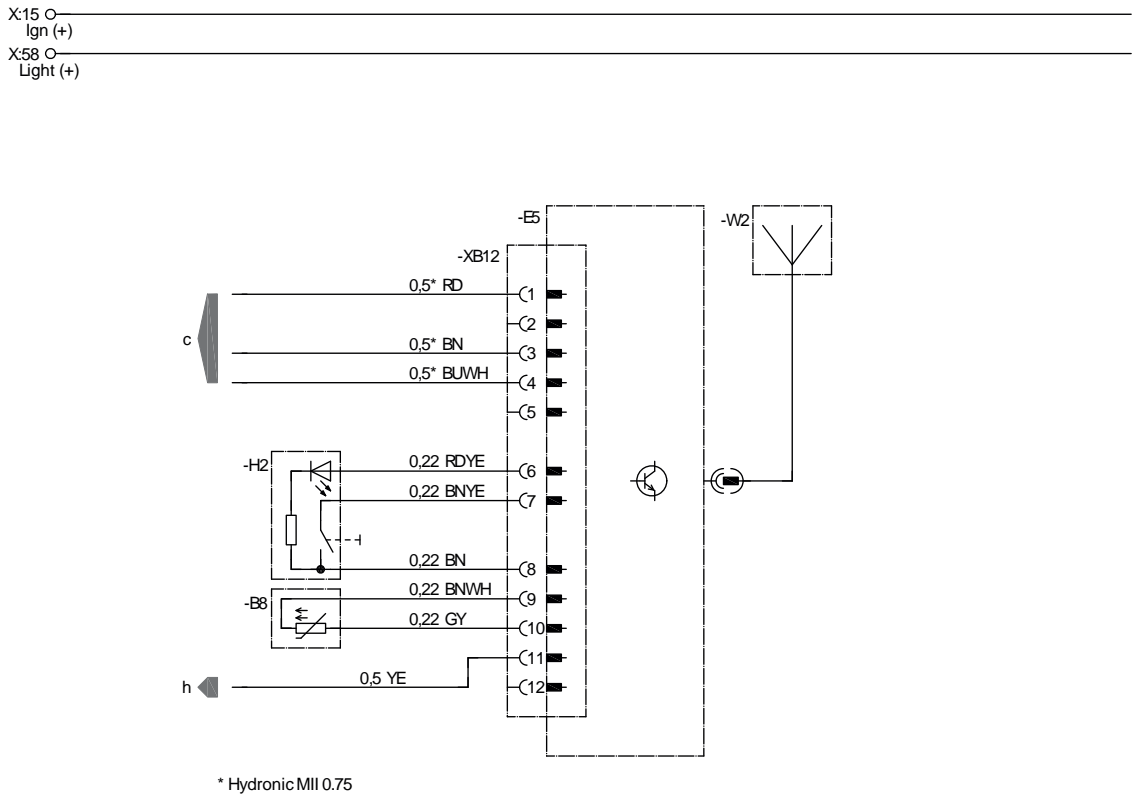

22 1000 34 97 27

- B8 Sensor, interior temperature
- E5 EasyStart Remote+ remote control
- H2 EasyStart Remote / Remote+ button
- W2 EasyStart Remote / Remote+ antenna
- c to the heater
- h for example, vehicle fan relay activation (max. 500 mA)

#### CABLE COLOURS

RD	red	GY	grey	BK	black
BU	blue	YE	yellow	GN	green
WH	white	VT	violet	BN	brown

## 5 CIRCUIT DIAGRAM

### OVERVIEW OF THE CIRCUIT DIAGRAMS

#### EASYSTART REMOTE / SELECT / CALL / ALTITUDE KIT / SPECIAL FUNCTIONS

REMOTE →	1 HEATER	
	Hydronic, Hydronic II, Hydronic II C, Hydronic II Comfort, Hydronic M II	<a href="#">86</a>
SELECT →	1 HEATER	
	Hydronic, Hydronic II, Hydronic II C, Hydronic II Comfort, Hydronic M II	<a href="#">87</a>
	Airtronic, Airtronic M, Airtronic L	<a href="#">88</a>
	Airtronic, Airtronic M, Airtronic L with external control temperature sensor, interior	<a href="#">89</a>
CALL →	1 HEATER	
	Hydronic, Hydronic II, Hydronic II C, Hydronic II Comfort, Hydronic M II	<a href="#">90</a>
	Airtronic, Airtronic M, Airtronic L	<a href="#">91</a>
	Airtronic, Airtronic M, Airtronic L with external control temperature sensor, interior	<a href="#">92</a>
	Hydronic auxiliary heater	<a href="#">93</a>
ALTITUDE SENSOR →	1 HEATER	
	EasyStart Timer, Remote, Remote+, Select, Call	
	Hydronic, Hydronic II, Hydronic II C, Hydronic II Comfort connection (all unit versions installed with altitude sensor)	<a href="#">94</a>
	EasyStart Timer, Remote+, Select, Call	
	Airtronic, Airtronic M, Airtronic L connection (all unit versions installed with altitude sensor)	<a href="#">95</a>
	EasyStart control unit connection via switch-on signal S+	
	Hydronic, Hydronic II, Hydronic II C, Hydronic II Comfort (all unit versions installed with altitude sensor)	<a href="#">96</a>
ALTITUDE SENSOR →	2 HEATERS	
	Connection of EasyStart control units to 2 heaters with altitude sensor	<a href="#">97</a>
	Connection of 2 EasyStart control units to 2 heaters with altitude sensor	<a href="#">98</a>
SPECIAL FUNCTION		
	Measurement of the battery voltage with EasyStart Timer / Select	
	Hydronic, Hydronic II, Hydronic II C, Hydronic II Comfort, Hydronic M II or Airtronic, Airtronic M, Airtronic L connection	<a href="#">99</a>

## 5 CIRCUIT DIAGRAM

### EASYSTART REMOTE CONNECTION

Hydronic, Hydronic II, Hydronic II C, Hydronic II Comfort, Hydronic M II

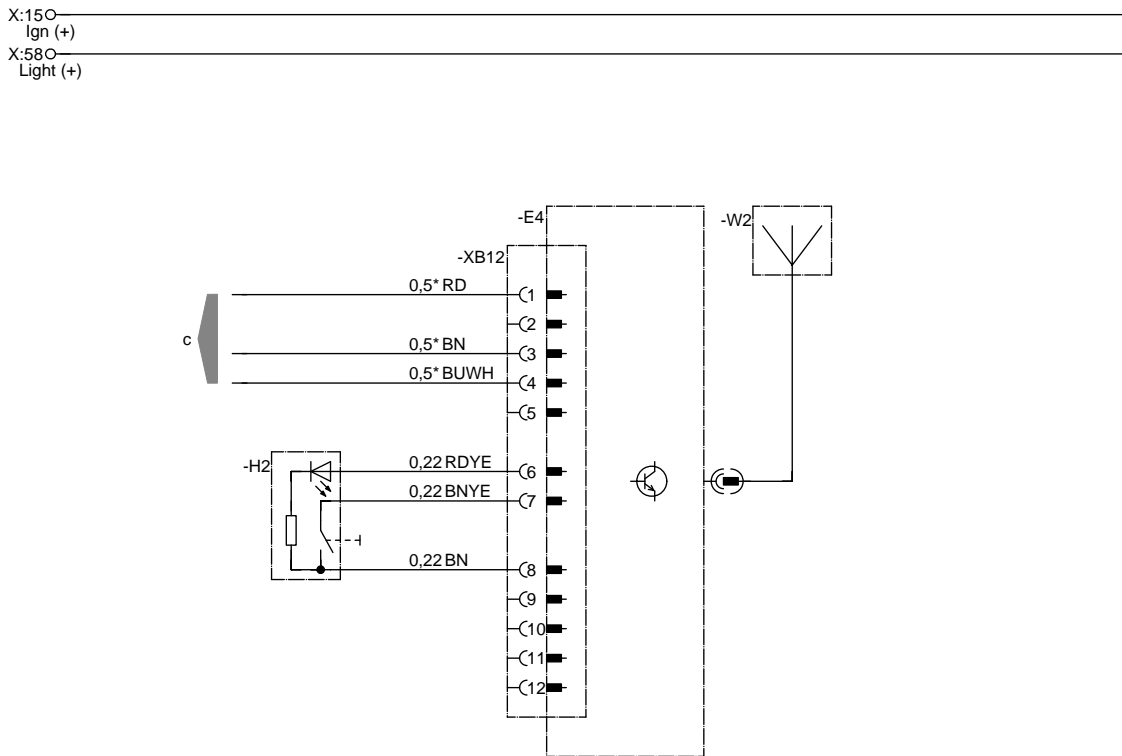

\* Hydronic MII 0,75

22 1000 34 97 33

- E4 EasyStart Remote radio remote control
- H2 EasyStart Remote / Remote+ button
- W2 EasyStart Remote / Remote+ antenna
- c to the heater

#### CABLE COLOURS

RD	red	GY	grey	BK	black
BU	blue	YE	yellow	GN	green
WH	white	VT	violet	BN	brown

## 5 CIRCUIT DIAGRAM

### EASystART SELECT CONNECTION

Hydronic, Hydronic II, Hydronic II C, Hydronic II Comfort, Hydronic M II

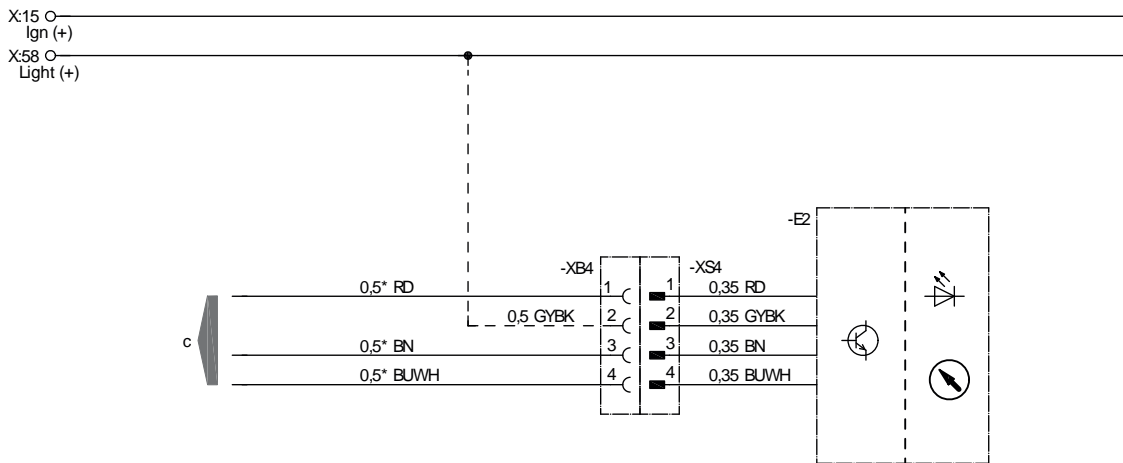

\* Hydronic MII 0.75

22 1000 34 97 34

-E2 EasyStart Select control unit  
c to the heater

#### CABLE COLOURS

RD	red	GY	grey	BK	black
BU	blue	YE	yellow	GN	green
WH	white	VT	violet	BN	brown

## 5 CIRCUIT DIAGRAM

### EASystart SELECT CONNECTION

Airtronic, Airtronic M, Airtronic L

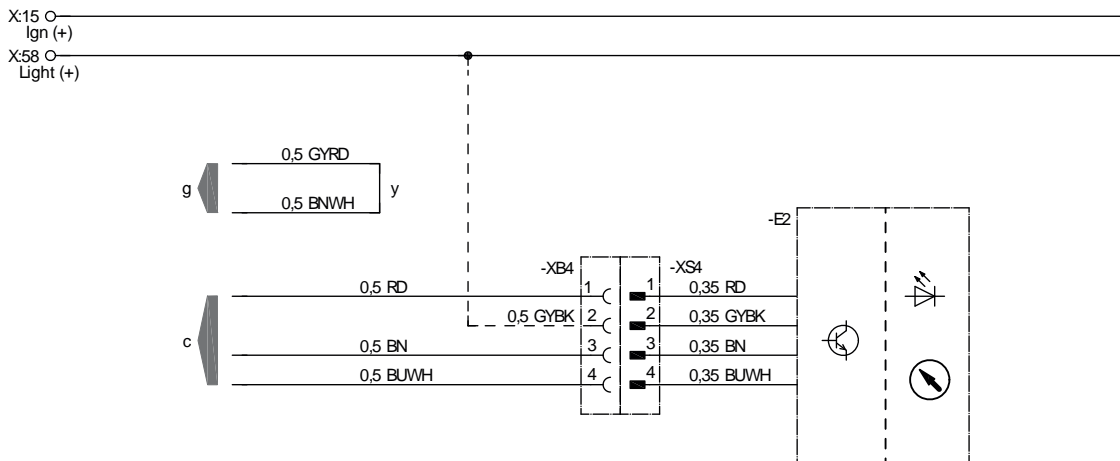

22 1000 34 97 35

- E2 EasyStart Select control unit
- c to the heater
- g to the heater
- y Connect cables and insulate

#### CABLE COLOURS

RD	red	GY	grey	BK	black
BU	blue	YE	yellow	GN	green
WH	white	VT	violet	BN	brown



## 5 CIRCUIT DIAGRAM

### EASYSTART SELECT CONNECTION

Airtronic, Airtronic M, Airtronic L with external control temperature sensor, interior

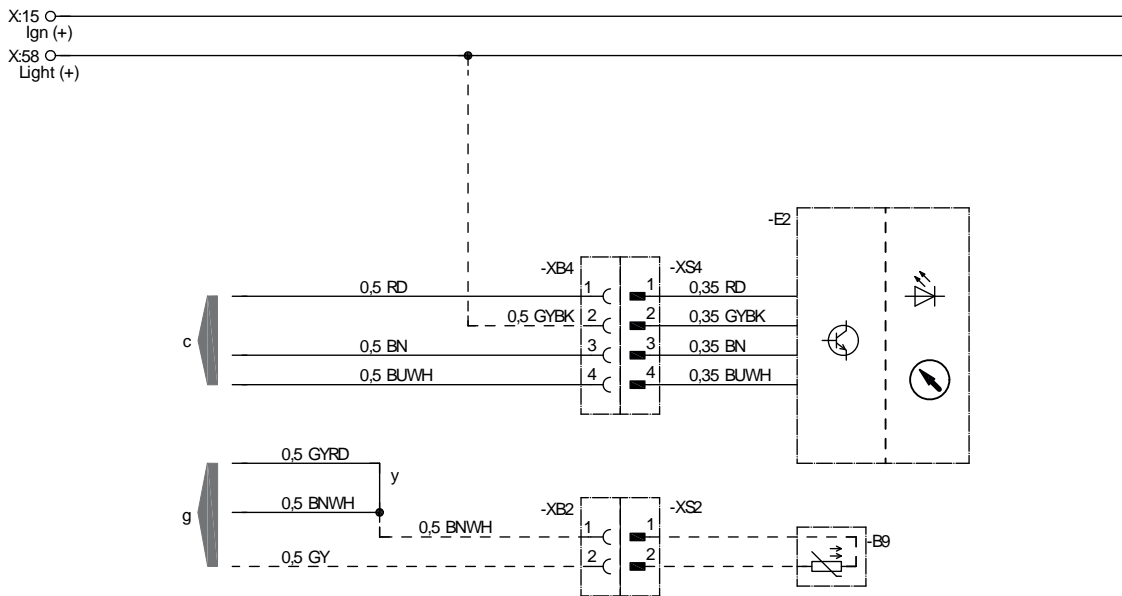

22 1000 34 97 72

- B9 External control temperature sensor, interior
- E2 EasyStart Select control unit
- c to the heater
- g to the heater
- y Connect cables and insulate

#### CABLE COLOURS

RD	red	GY	grey	BK	black
BU	blue	YE	yellow	GN	green
WH	white	VT	violet	BN	brown

## 5 CIRCUIT DIAGRAM

### EASystART CALL CONNECTION

Hydronic, Hydronic II, Hydronic II C, Hydronic II Comfort, Hydronic M II

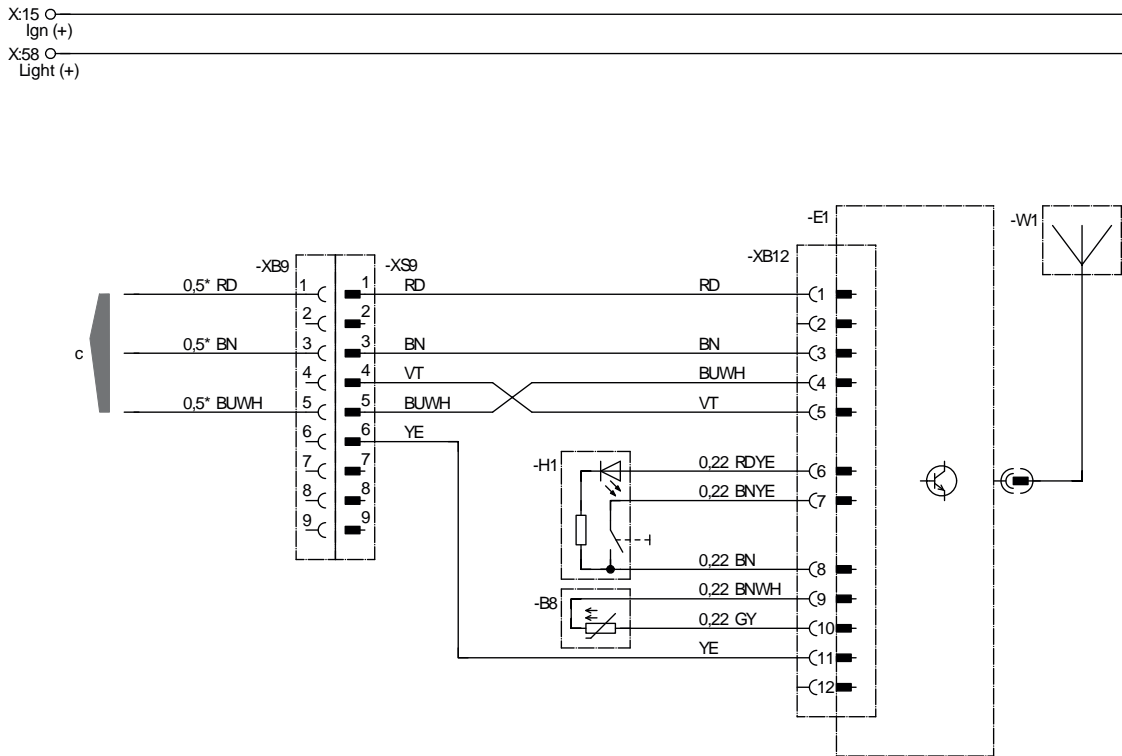

\* Hydronic MII 0,75

22 1000 34 97 18

- B8 Sensor, interior temperature
- E1 EasyStart Call radio remote control
- H1 EasyStart Call button
- W1 EasyStart Call antenna
- c to the heater

#### CABLE COLOURS

RD	red	GY	grey	BK	black
BU	blue	YE	yellow	GN	green
WH	white	VT	violet	BN	brown

## 5 CIRCUIT DIAGRAM

### EASystart CALL CONNECTION Airtronic, Airtronic M, Airtronic L

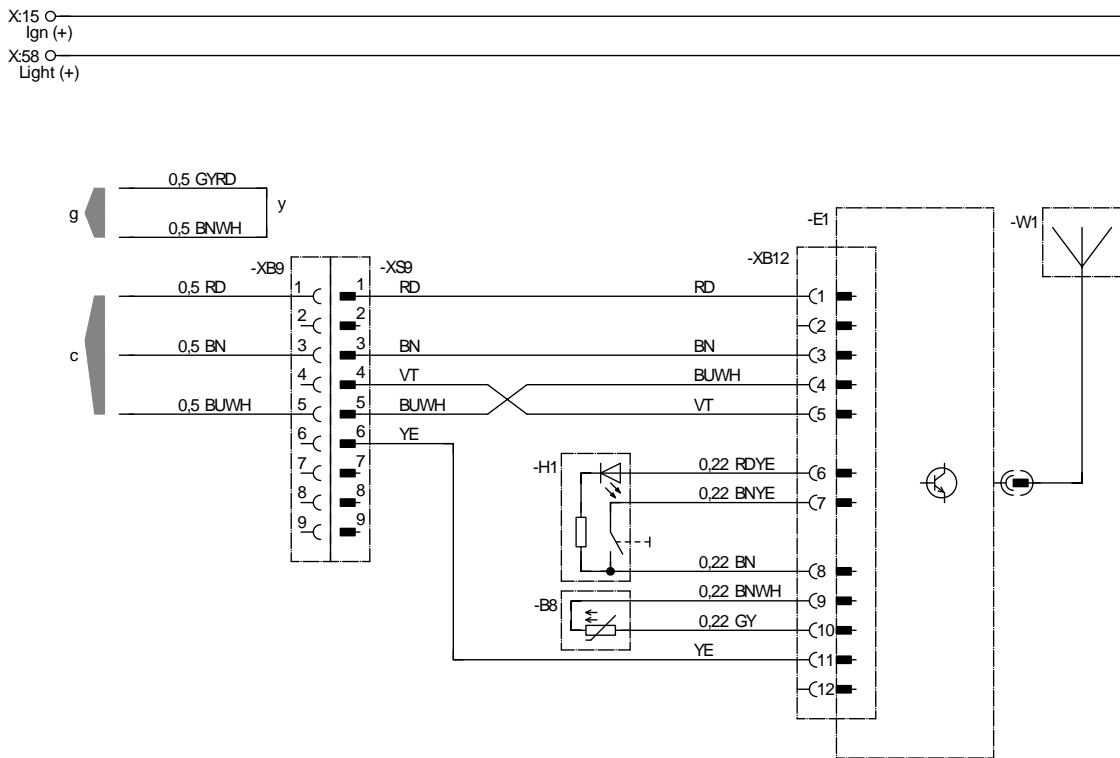

22 1000 34 97 20

- B8 Sensor, interior temperature
- E1 EasyStart Call radio remote control
- H1 EasyStart Call button
- W1 EasyStart Call antenna
- c to the heater
- g to the heater
- y Connect cables and insulate

#### CABLE COLOURS

RD	red	GY	grey	BK	black
BU	blue	YE	yellow	GN	green
WH	white	VT	violet	BN	brown

## 5 CIRCUIT DIAGRAM

### EASystART CALL CONNECTION

Airtronic, Airtronic M, Airtronic L with external control temperature sensor, interior

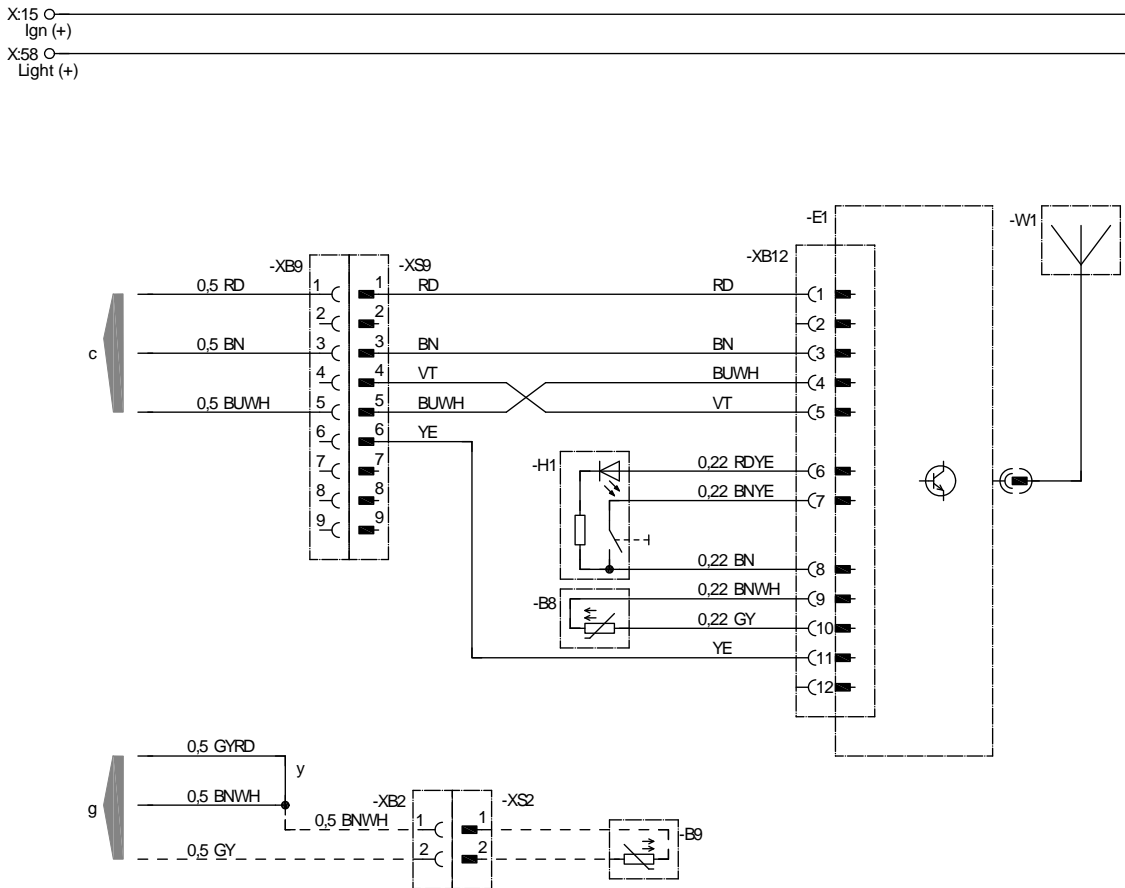

22 1000 34 97 40

- B8 Sensor, interior temperature
- B9 External control temperature sensor, interior
- E1 EasyStart Call radio remote control
- H1 EasyStart Call button
- W1 EasyStart Call antenna
- c to the heater
- g to the heater
- y Connect cables and insulate

#### CABLE COLOURS

RD	red	GY	grey	BK	black
BU	blue	YE	yellow	GN	green
WH	white	VT	violet	BN	brown

## 5 CIRCUIT DIAGRAM

### EASYSTART CALL CONNECTION

Hydronic auxiliary heater

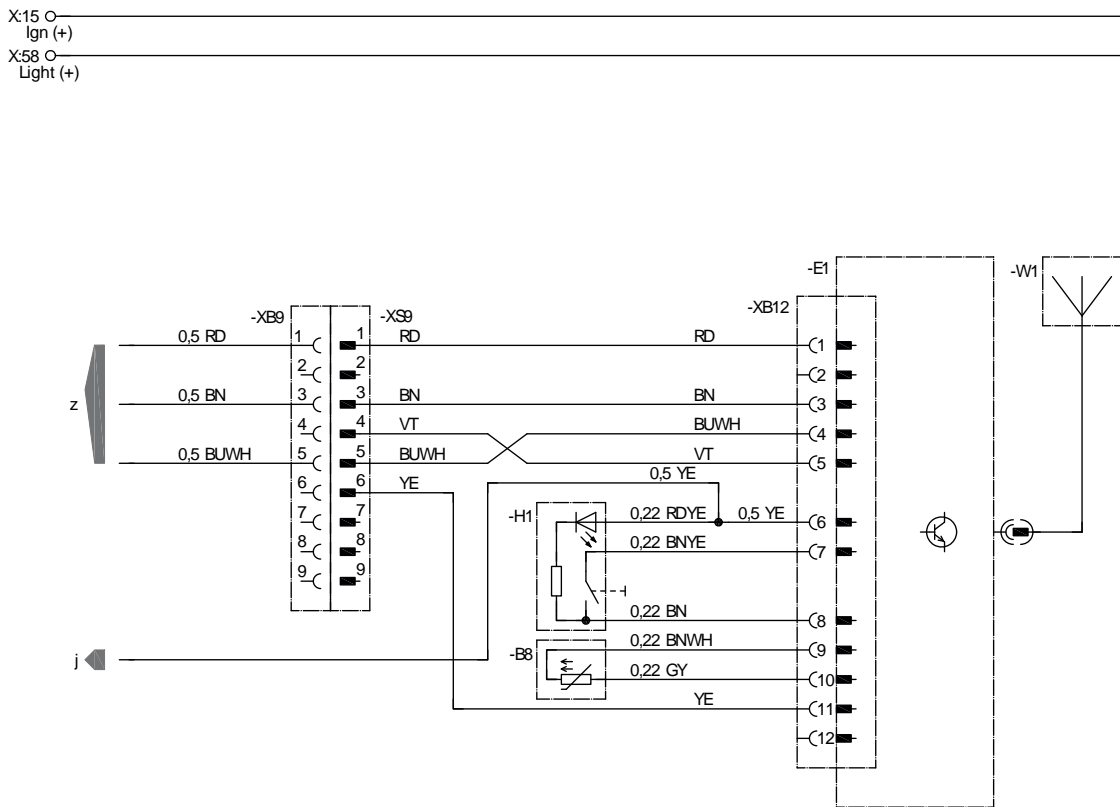

22 1000 34 97 52

- B8 Sensor, interior temperature
- E1 EasyStart Call radio remote control
- H1 EasyStart Call button
- W1 EasyStart Call antenna
- j to the relay for connection of water pump and vehicle fan (max. 500 mA)
- z to the auxiliary heater

#### CABLE COLOURS

RD	red	GY	grey	BK	black
BU	blue	YE	yellow	GN	green
WH	white	VT	violet	BN	brown

## 5 CIRCUIT DIAGRAM

### EASystart TIMER / REMOTE / REMOTE+ / SELECT / CALL CONNECTION

Hydronic, Hydronic II, Hydronic II C, Hydronic II Comfort, (all unit versions installed with altitude sensor)

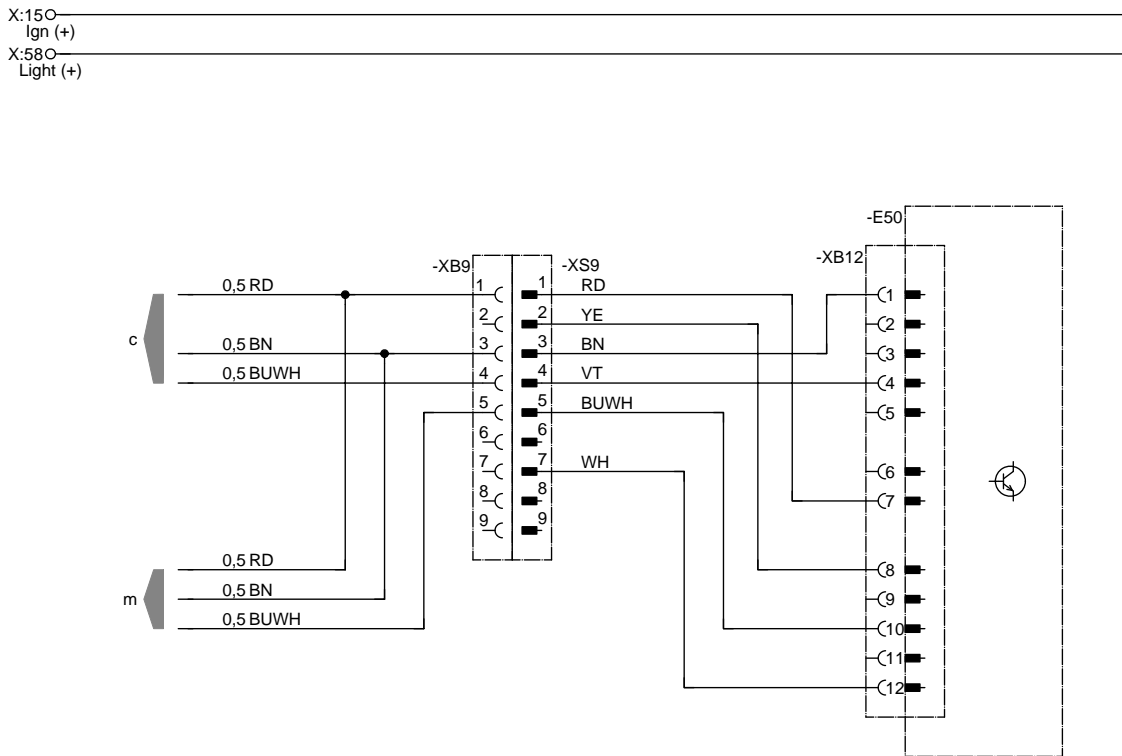

22 1000 34 97 36

-E50 Air pressure sensor  
 c to the heater  
 m to the control unit

#### CABLE COLOURS

RD	red	GY	grey	BK	black
BU	blue	YE	yellow	GN	green
WH	white	VT	violet	BN	brown

## 5 CIRCUIT DIAGRAM

### EASystart TIMER / REMOTE / REMOTE+ / SELECT / CALL CONNECTION

Airtronic, Airtronic M, Airtronic L (all unit versions installed with altitude sensor)

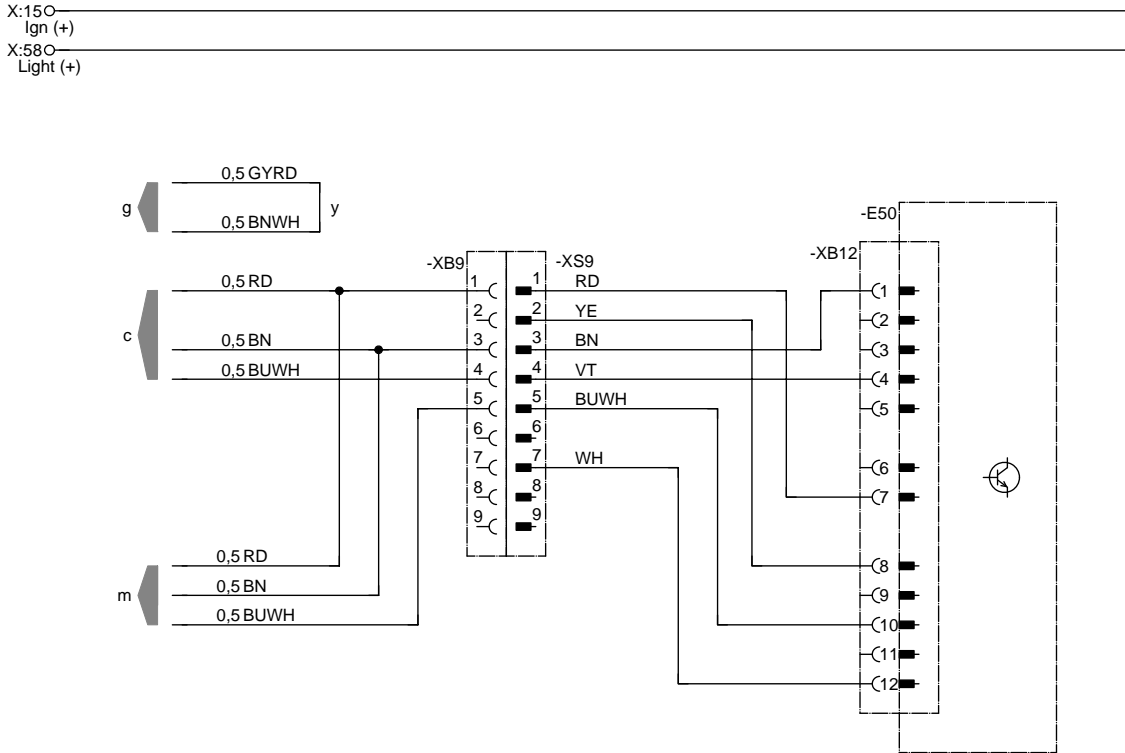

22 1000 34 97 37

- E50 Air pressure sensor
- c to the heater
- g to the heater
- m to the control unit
- y Connect cables and insulate

#### CABLE COLOURS

RD	red	GY	grey	BK	black
BU	blue	YE	yellow	GN	green
WH	white	VT	violet	BN	brown

## 5 CIRCUIT DIAGRAM

### CONNECTION OF EASYSTART CONTROL UNITS VIA SWITCH-ON SIGNAL S+

Hydronic, Hydronic II, Hydronic II C, Hydronic II Comfort (all unit versions installed with altitude sensor)

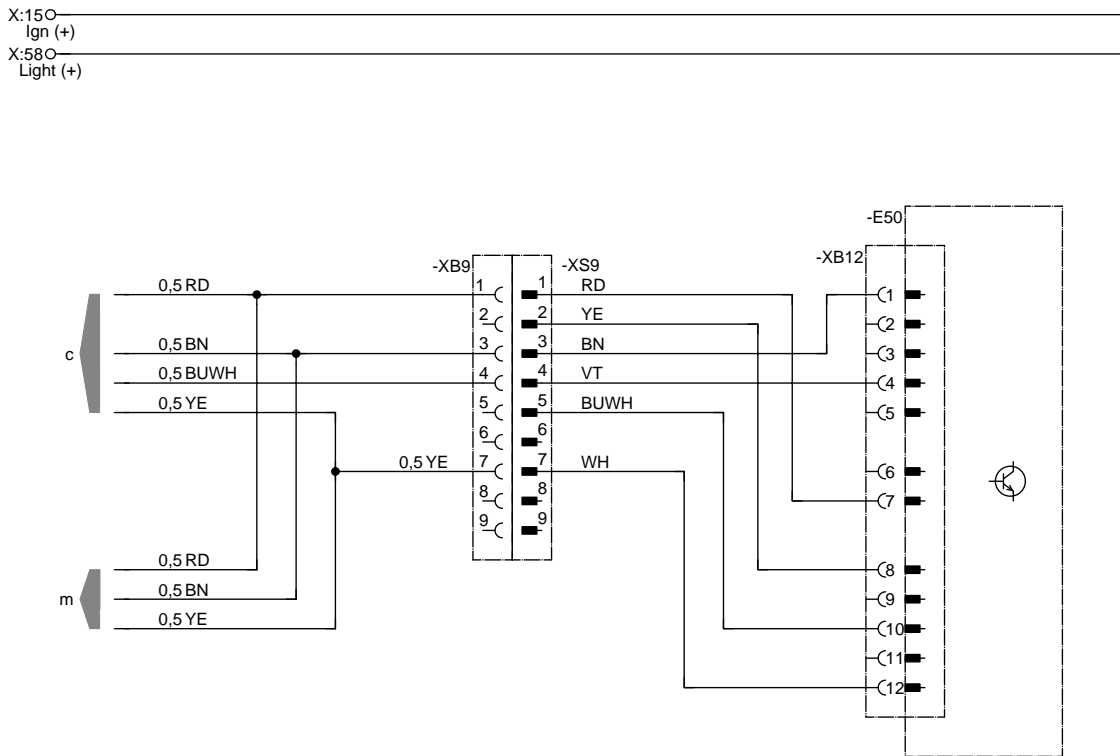

22 1000 34 97 38

-E50 Air pressure sensor  
 c to the heater  
 m to the control unit

#### CABLE COLOURS

RD	red	GY	grey	BK	black
BU	blue	YE	yellow	GN	green
WH	white	VT	violet	BN	brown



## 5 CIRCUIT DIAGRAM

### CONNECTION OF EASYSTART CONTROL UNITS TO 2 HEATERS WITH ALTITUDE SENSOR

**Note:** If using Airtronic, Airtronic M, Airtronic L the 0.5 GYRD and 0.5 BNWH cables in the heater cable harness must also be bridged. Connection of heater 1 and 2 via diagnostics cable

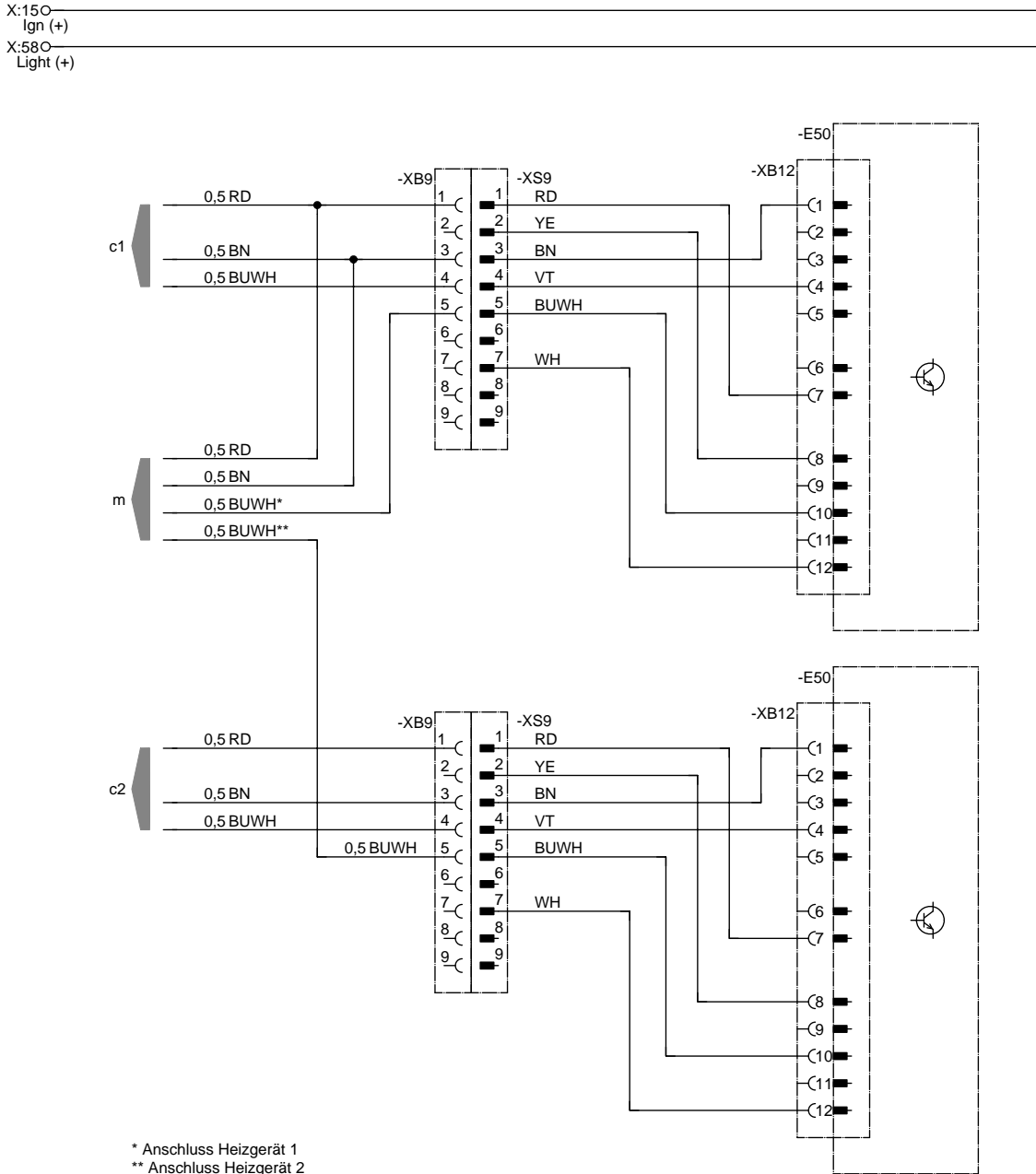

22 1000 34 97 69

- E50 Air pressure sensor
- c1 to heater 1
- c2 to heater 2
- m to the control unit

#### CABLE COLOURS

RD	red	GY	grey	BK	black
BU	blue	YE	yellow	GN	green
WH	white	VT	violet	BN	brown

## 5 CIRCUIT DIAGRAM

### CONNECTION OF 2 EASYSTART CONTROL UNITS TO 2 HEATERS WITH ALTITUDE SENSOR

**Note:** If using Airtronic, Airtronic M, Airtronic L the 0.5 GYRD and 0.5 BNWH cables in the heater cable harness must also be bridged. Connection of heater 1 via diagnostics cable, heater 2 via switch-on signal S+

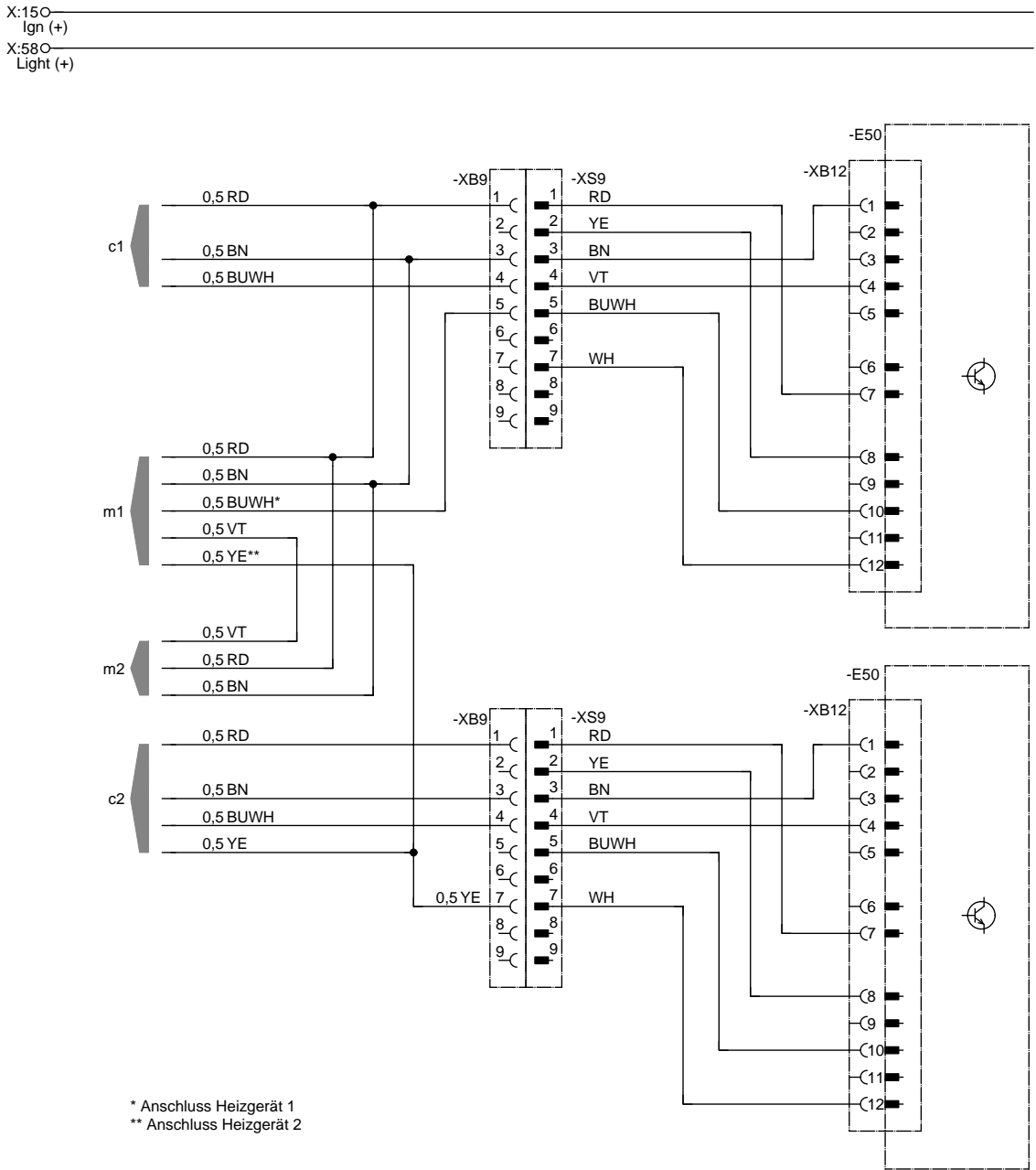

22 1000 34 97 70

- E50 Air pressure sensor
- c1 to heater 1
- c2 to heater 2
- m1 to control unit 1
- m2 to control unit 2

#### CABLE COLOURS

RD	red	GY	grey	BK	black
BU	blue	YE	yellow	GN	green
WH	white	VT	violet	BN	brown

## 5 CIRCUIT DIAGRAM

### MEASUREMENT OF THE BATTERY VOLTAGE WITH EASYSTART TIMER / SELECT CONNECTION

Hydronic, Hydronic II, Hydronic II C, Hydronic II Comfort, Hydronic M II

Airtronic, Airtronic M, Airtronic L

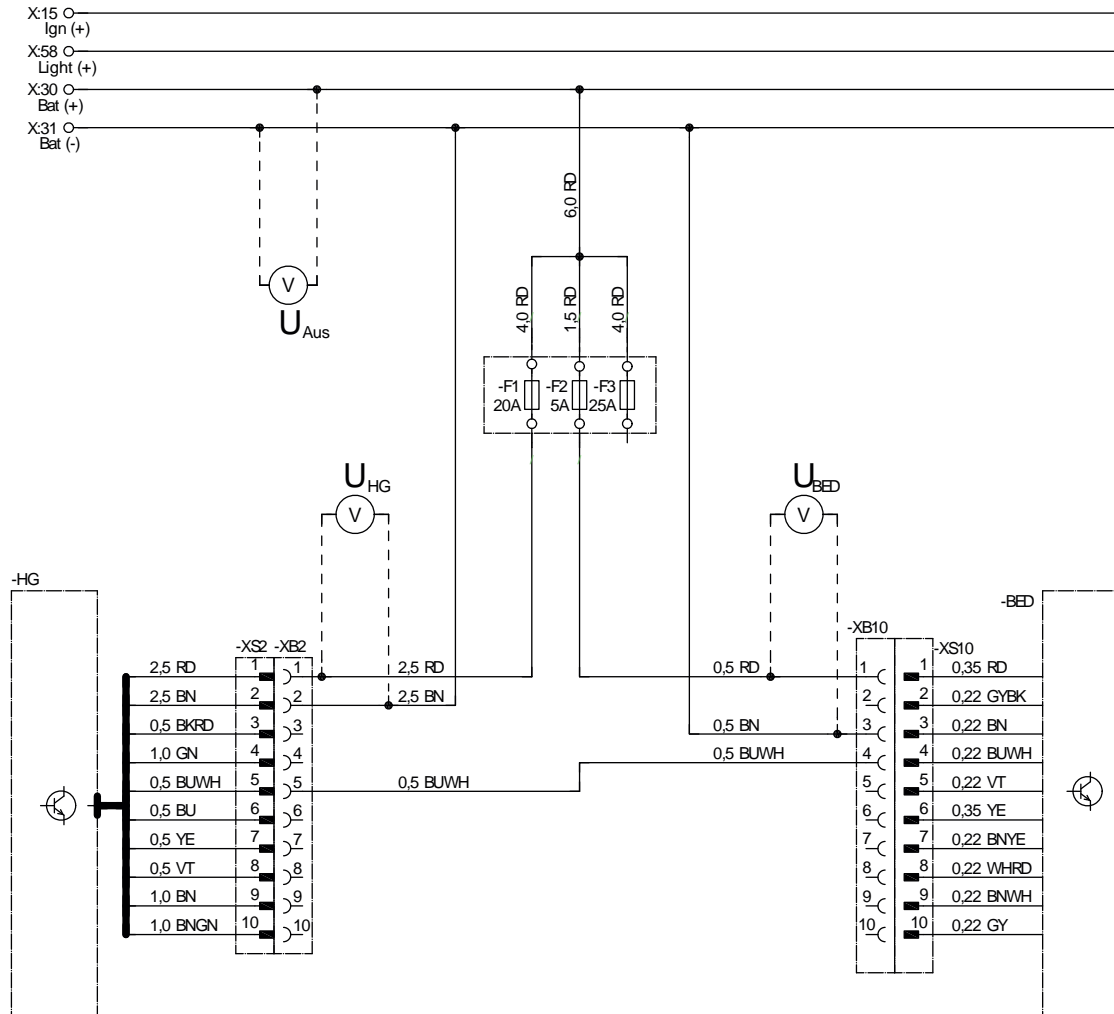

22 1000 34 97 71

- BED Control unit (Select or Timer)
- F1 Fuse, heater
- F2 Fuse, control unit
- F3 Fuse, vehicle fan
- HG Heater (Airtronic or Hydronic)

#### CABLE COLOURS

RD	red	GY	grey	BK	black
BU	blue	YE	yellow	GN	green
WH	white	VT	violet	BN	brown

**Headquarters:**

Eberspächer Climate Control Systems

GmbH & Co. KG

Eberspächerstraße 24

73730 Esslingen

Hotline: 03976 2350235

Fax hotline: 01805 262624

[info@eberspaecher.com](mailto:info@eberspaecher.com)

[www.eberspaecher.com](http://www.eberspaecher.com)

