



EMU-1

Engine Monitoring Unit
Analogue to NMEA 2000®

User Manual

For variant:
EMU-1-BAS

Issue 1.06

Contents

Company information	4
Important Notices	5
Trademarks and Registered Trademarks.....	5
Fair use Statement.....	5
Technical Accuracy.....	5
Product Registration.....	5
Product Guarantee.....	5
Product Disposal.....	5
Product Overview	6
Figure 1 - Example of an EMU-1 Installation.....	6
Package Contents.....	6
Installation Warnings	7
Installation Order	8
Selecting a Mounting Location	8
Figure 2 - Example of a Typical Installation.....	8
Wiring Loom Lengths	9
Installations without Gauges.....	9
Installations with Gauges.....	9
Figure 3 - Connecting to Senders.....	9
Figure 4 - Connecting to Gauges.....	9
Mounting the EMU-1	10
Bulkhead Mounting.....	10
DIN Rail Mounting.....	10
Figure 5 - Mounting Options.....	10
Connecting to an NMEA 2000 Network	11
NMEA 2000 Networks.....	11
NMEA 2000 Minimum Network Requirements.....	11
Figure 6 - NMEA 2000 Minimum Network Requirements Diagram.....	11
Gauge Input Connections	12
Insulated Terminal Sender with Gauge.....	12
Insulated Terminal Sender without Gauge.....	12
Standard Grounded Sender with Gauge.....	12
Standard Grounded Sender without Gauge.....	12
Figure 7 - Gauge Input Connection Examples.....	12
Alarm Input Connections	13
Figure 8 - Alarm Input Connection Examples.....	13
Tacho Input Connections	14
Ignition Coil.....	14
Alternator.....	14
Hall Effect and Electronic Pulse Senders.....	14
Inductive Senders.....	14
Figure 9 - Tacho Input Connections.....	14

Calculating Tacho PPR.....	15
Auxiliary Input Connections.....	15
Battery Voltage Sensing.....	15
Power Requirements.....	15
Connecting the Power.....	15
Grounding Requirements.....	15
Factory Configuration.....	16
Configuring the EMU-1.....	16
Configuration Requirements.....	16
Troubleshooting Guide.....	17
Technical Support and the Returns Procedure.....	17
NMEA 2000 PGN List.....	18
Dimension Diagram.....	18
Figure 14 - Dimension Diagram.....	18
Specifications.....	19
EMU-1 Product Order Codes.....	20

Company information

Active Research Ltd
 Unit 5 Wessex Trade Centre
 Ringwood Road
 Poole, Dorset
 UK, BH12 3PF

Telephone: +44 (0)1202 746682
 Email: support@actisense.com
 Web: www.actisense.com

Important Notices



The EMU-1 has been certified to comply with the European directive for Electromagnetic Compatibility (EN60945) and is appropriately CE marked. Operation of the unit should be in conjunction with appropriate CE approved shielded connectors and cabling used in accordance with the CE directive EN60945. Any EMC related issues should be reported to Active Research Limited immediately to allow the company to rectify or resolve EMC related problems in accordance with its obligations under EN60945.

If the unit is connected such that compliance failure occurs beyond the company's control, the company shall not be held responsible for compliance failure until suitable EMC guidelines for connection are seen to have been taken.

Trademarks and Registered Trademarks

Actisense® and the Actisense logo are registered trademarks of Active Research Limited. All other trademarks are the property of their respective owners.

The NMEA® name and NMEA logo are copyright held by the NMEA. All uses in this manual are by permission and no claim on the right to the NMEA name or logo are made in this manual.

Fair use Statement

The contents of this manual may not be transferred or copied without the express written permission of Active Research Limited.

Copyright © 2013 Active Research Ltd. All rights reserved.

Technical Accuracy

To the best of our knowledge the information contained in this document was correct at the time it was produced. Active Research Ltd cannot accept liability for any inaccuracies or omissions.

The products described in this manual and the specifications thereof may be changed without prior notice. Active Research Ltd cannot accept any liability for differences between the product and this document. To check for updated information and specifications please contact Active Research Limited.

Active Research Limited will not be liable for infringement of copyright, industrial property rights, or other rights of a third party caused by the use of information or drawings described in this manual.

Product Registration

Please register your product via the [online form](#).

Your product package includes a unit serial number. The serial number is six digits and can be found below the barcode on the white label on the top of the EMU-1. Alternatively, if your EMU-1 is inaccessible, you will find the serial number under the product information on the 'network list' page of an NMEA 2000 MFD.

Your registration will assist Actisense Support to link your product to your details, simplifying any future assistance you may require.

Product Guarantee

This product comes with a three year 'return to base' guarantee. If you suspect that the unit is faulty please refer to the ["Troubleshooting Guide" on page 17](#).

It is a requirement of the guarantee that all installations of electronic equipment follow the NMEA 0400 specification. Any connection to a battery or power supply must meet the mandatory essential safety requirements that may be imposed by local regulatory agencies.



Actisense products are intended for use in a marine environment, primarily for below deck use. If a product is to be used in a more severe environment, such use may be considered misuse under the Active Research Limited guarantee.

Product Disposal

Please dispose of this product in accordance with the WEEE Directive. The product should be taken to a registered establishment for the disposal of electronic equipment.

Product Overview

The EMU-1 converts data from analogue engine senders into NMEA 2000 compatible data, allowing modern NMEA 2000 display devices to monitor the engine data and associated gauge levels aboard a vessel.

The unit has been designed to connect in parallel to an existing gauge, so existing instruments can still be used. The EMU-1 can also be used straight from the sender without a gauge being present. In effect the EMU-1 can be installed for most engine makes and models.

The EMU-1 provides 6 dedicated Gauge inputs, capable of measuring the output from the required engine senders. The unit also provides 4 Alarm inputs (e.g. high temp, low pressure), 2 Tacho inputs, and 2 user definable Auxiliary inputs.

See the [EMU-1 FAQs](#) section to find which senders are supported. See “[Table 3 - NMEA 2000 PGN List](#)” on page 18 for a list of NMEA 2000 PGNs that the EMU-1 supports. Refer to the EMU Config Tool User Manual on the [EMU-1 downloads](#) page for instructions on how to configure the EMU-1.

Figure 1 - Example of an EMU-1 Installation

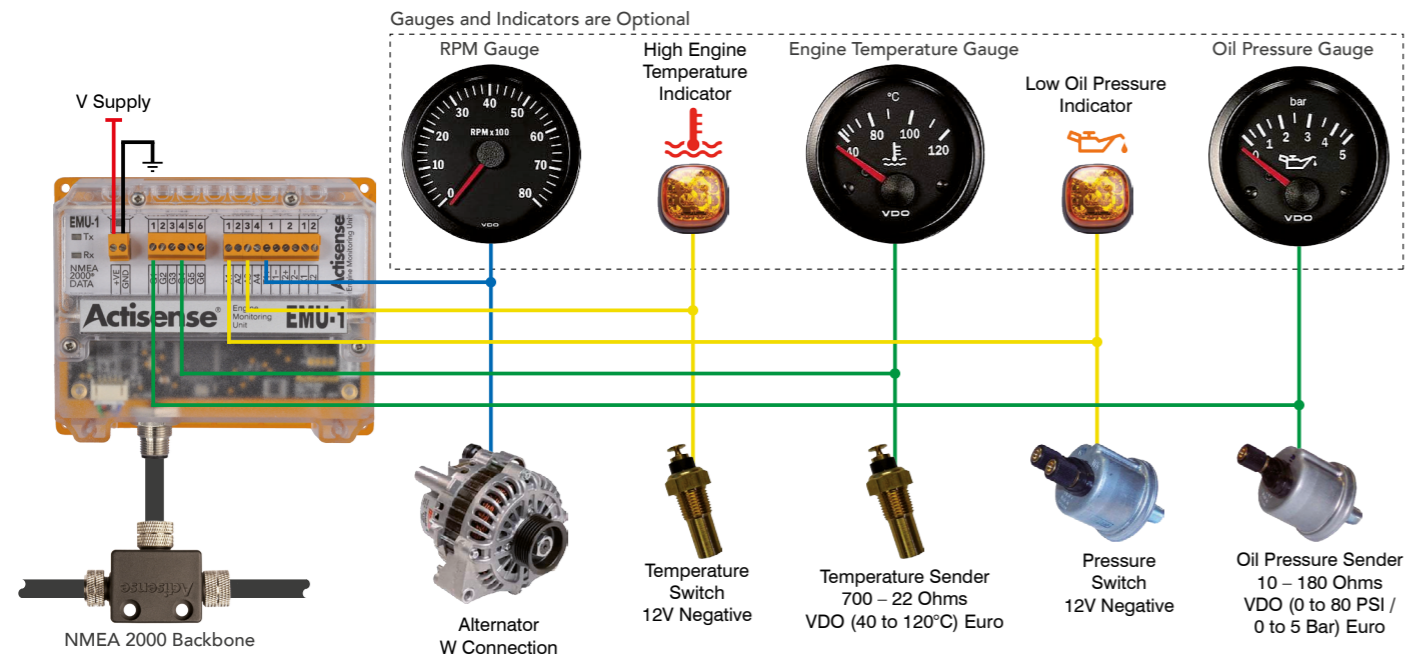

Package Contents

- 1 x EMU-1-BAS with pluggable screw terminals and NMEA 2000 dust cover.
- 1 x Actisense CD in sleeve (Documents and Software)
- 1 x EMU-1 user manual
- 1 x Connector cover
- 4 x Connector cover screws
- 4 x Mounting screws

Accessories Supplied Separately

- NGT-1 (either USB or ISO variant) for configuring the EMU-1
- DIN-KIT-1 mounting kit for use with DIN rails

Installation Warnings



All warnings and notices must be followed to ensure the correct operation of the EMU-1. Incorrect installation may invalidate the guarantee.

It is highly recommended that all of the installation instructions are read before commencing the installation. There are important warnings and notes throughout the manual that should be considered before the installation is attempted.

Warning 1: Accuracy

The Actisense EMU-1 is designed to reliably measure voltage levels on senders and sensors; the accuracy is reliant upon the correct installation and the correct configuration of the EMU-1. Furthermore the information present in the associated NMEA 2000 PGN's which are output by the EMU-1 depends on configuration parameters being set correctly. Therefore, the EMU-1 should only be used as an aid to vessel monitoring, control or navigation and should not be used as a replacement for traditional aids and techniques.

Warning 2: Installation and Operation

This product must be installed and operated in accordance with the instructions provided. Failure to do so could result in personal injury, damage to your boat and/or poor product performance.

Warning 3: Installation Code of Practice

When wiring the power supply to the EMU-1 ensure the isolation switch is off. Wiring the EMU-1 while the connection is live may damage the EMU-1 and is in breach of the guarantee. All wiring should be in accordance with the regional code of practice for installations.

Warning 4: Firmware Updates

It is highly recommended that the Firmware is kept up to date in the EMU-1. Please check to ensure your EMU-1 shipped with the latest Firmware. You can do this by locating the manufacturers software ID for your EMU-1 on the network list found in most NMEA 2000 displays or using our freely available NMEA Reader. The latest firmware version number and details of supporting software such as NMEA Reader can be found on the [EMU-1 downloads](#) web page.

Warning 5: NGT-1 Support

It is highly recommended that an NGT-1 (either USB or ISO variants) be available for every EMU-1 installation. The NGT-1 can be used to update the Firmware, connect to the Configuration Tool and display data on a PC running compatible software. Details of the NGT-1 can be found here www.actisense.com/NGT-1.

Warning 6: Mounting Requirements

Select a flat location to mount the EMU-1. Mounting on a contoured surface may cause damage to the case. Do not mount the EMU-1 while the device is powered. Do not mount the EMU-1 while the NMEA 2000 cable is connected. Do not mount the EMU-1 while the engine cable harness is connected. Note that the terminals are pluggable for easy disconnection when mounting or removing the EMU-1.

Warning 7: Mounting Locations

Do not mount the EMU-1 in the same plane as transmitting or receiving antennas. Do not mount the EMU-1 close to an electronic compass.

Warning 8: Wire Noise

Avoid running noisy wires (such as those connected to ignition coils) adjacent to sensitive gauge or alarm wires as noise may be induced into these wires and this may result in inaccurate measurements and corresponding inaccurate data being output to the NMEA 2000 bus.

Installation Order

1. Select mounting location: Ensure the EMU-1 can be mounted in a suitable location relative to the NMEA 2000 bus and the senders or gauges. See **"Selecting a Mounting Location"** on page 8.
2. Mount the EMU-1 to the bulkhead, cabinet or other suitable location. See **"Mounting the EMU-1"** on page 10.
3. Connect to the NMEA 2000 network. See **"Connecting to an NMEA 2000 Network"** on page 11.
4. Connect the Gauge inputs. See **"Gauge Input Connections"** on page 12.
5. Connect the Alarm inputs. See **"Alarm Input Connections"** on page 13.
6. Connect the Tacho inputs. See **"Tacho Input Connections"** on page 14.
7. Connect the Power to the EMU-1. See **"Power Requirements"** on page 15.
8. Configure the EMU-1. See **"Configuring the EMU-1"** on page 16.

Selecting a Mounting Location

"Figure 2 - Example of a Typical Installation" shows an example installation. This gives an idea of the connections that need to be made to install the EMU-1. All these connections need to be considered before selecting an installation location. Refer to **"Warning 7: Mounting Locations"** on page 7.

Figure 2 - Example of a Typical Installation

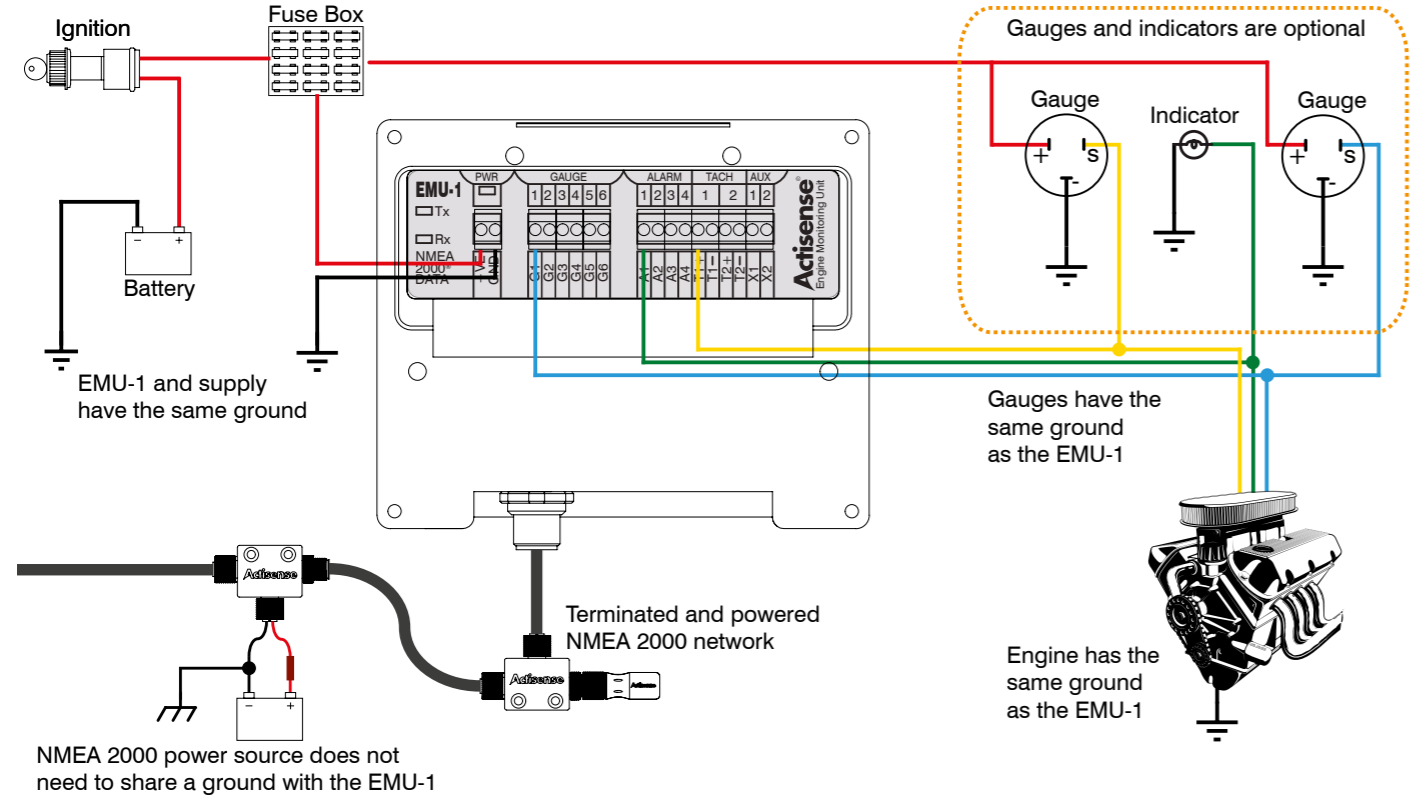

Note: Wire colours are for reference only

Wiring Loom Lengths

Installations without Gauges

The EMU-1 can be used on senders where the analogue gauges are not present, connecting directly to the sender to be measured. In this case it is recommended that the EMU-1 be mounted close to the engine. The cable length between the sender and the EMU-1 should typically not exceed 2 metres.

Installations with Gauges

The EMU-1 can be used in parallel with existing gauges to compliment the information already displayed. In this case it is recommended that the EMU-1 be mounted close to the engine. The cable length between the sender and the EMU-1 should typically not exceed 2 metres.

Figure 3 - Connecting to Senders

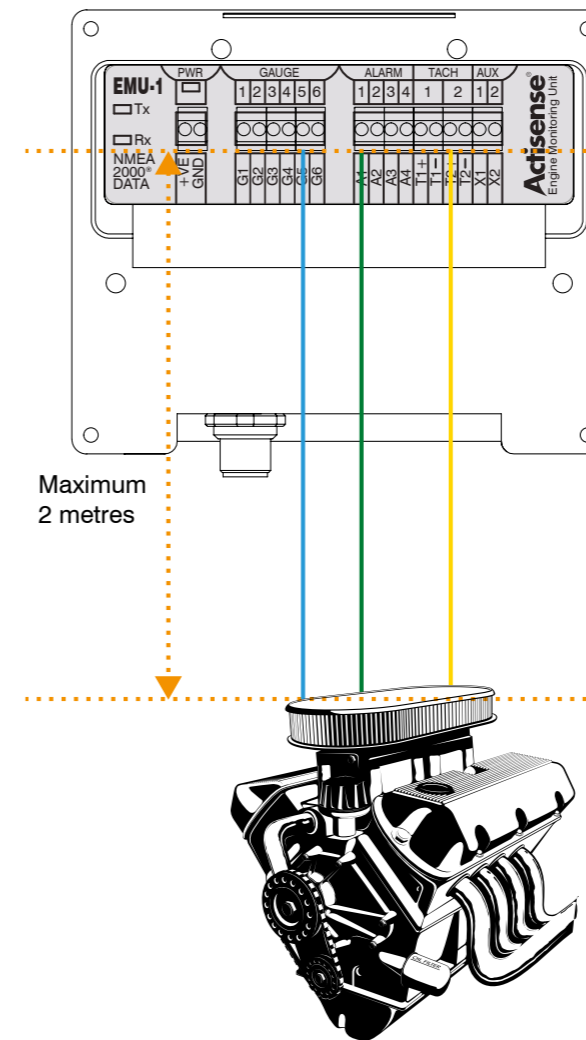

Note: Wire colours are for reference only

Figure 4 - Connecting to Gauges

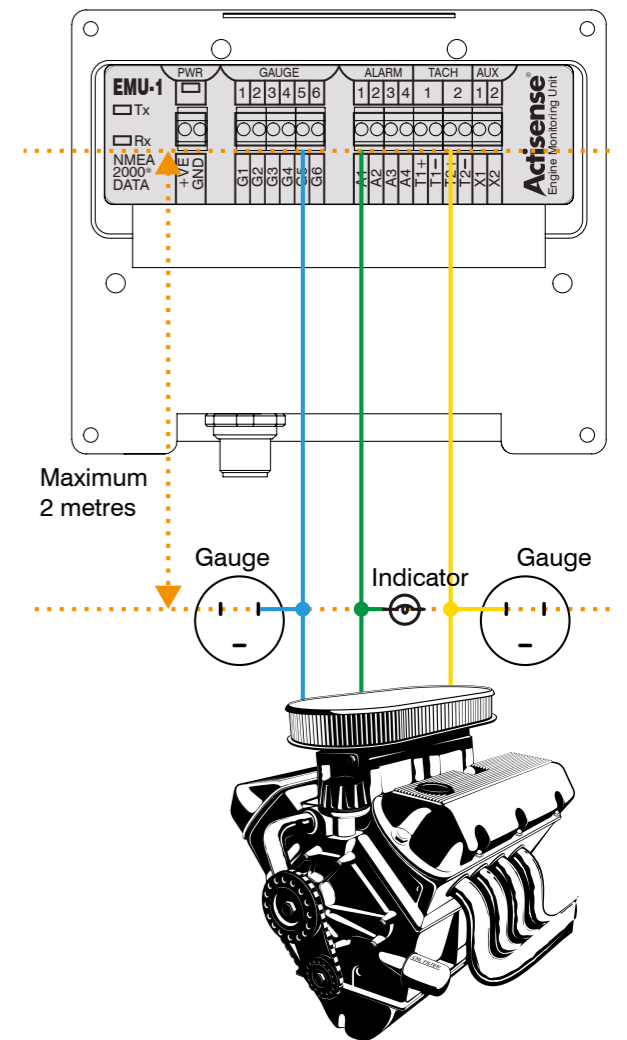

Mounting the EMU-1

See “[Connecting to an NMEA 2000 Network](#)” on page 11 before finalising the installation location.

Bulkhead Mounting

- Use the EMU-1 as a template to locate and mark the drill holes for mounting. Do not attempt to drill the holes while the EMU-1 is in position.
- Refer to “[Warning 6: Mounting Requirements](#)” on page 7.
- Four M3.5 stainless steel pan-head screws are provided with the EMU-1 for mounting to the bulkhead. If these screws are lost, suitable alternatives may be used. **Note:** Using larger screws can damage the housing and invalidate the guarantee.
- Secure directly to a bulkhead using the mounting screws provided with the unit. Refer to the “[Dimension Diagram](#)” on page 18.

DIN Rail Mounting

Requirements:

- An Actisense DIN Rail Kit (not included with the EMU-1) Part Code: **DIN-KIT-1**
 - A top hat rail, type EN 50 022 or a G section rail, type EN 50 035.
- Mounting using a different rail type or an alternative mounting kit may breach the terms and conditions of the guarantee.

Method:

- Refer to “[Warning 6: Mounting Requirements](#)” on page 7.
- Attach the mounting kit to the base of the EMU-1 with the kit supplied screws. There is provision to mount the EMU-1 vertically or horizontally (recommended). Using alternative screws may not be reliable or may result in damage to the housing and invalidate the guarantee.

Figure 5 - Mounting Options

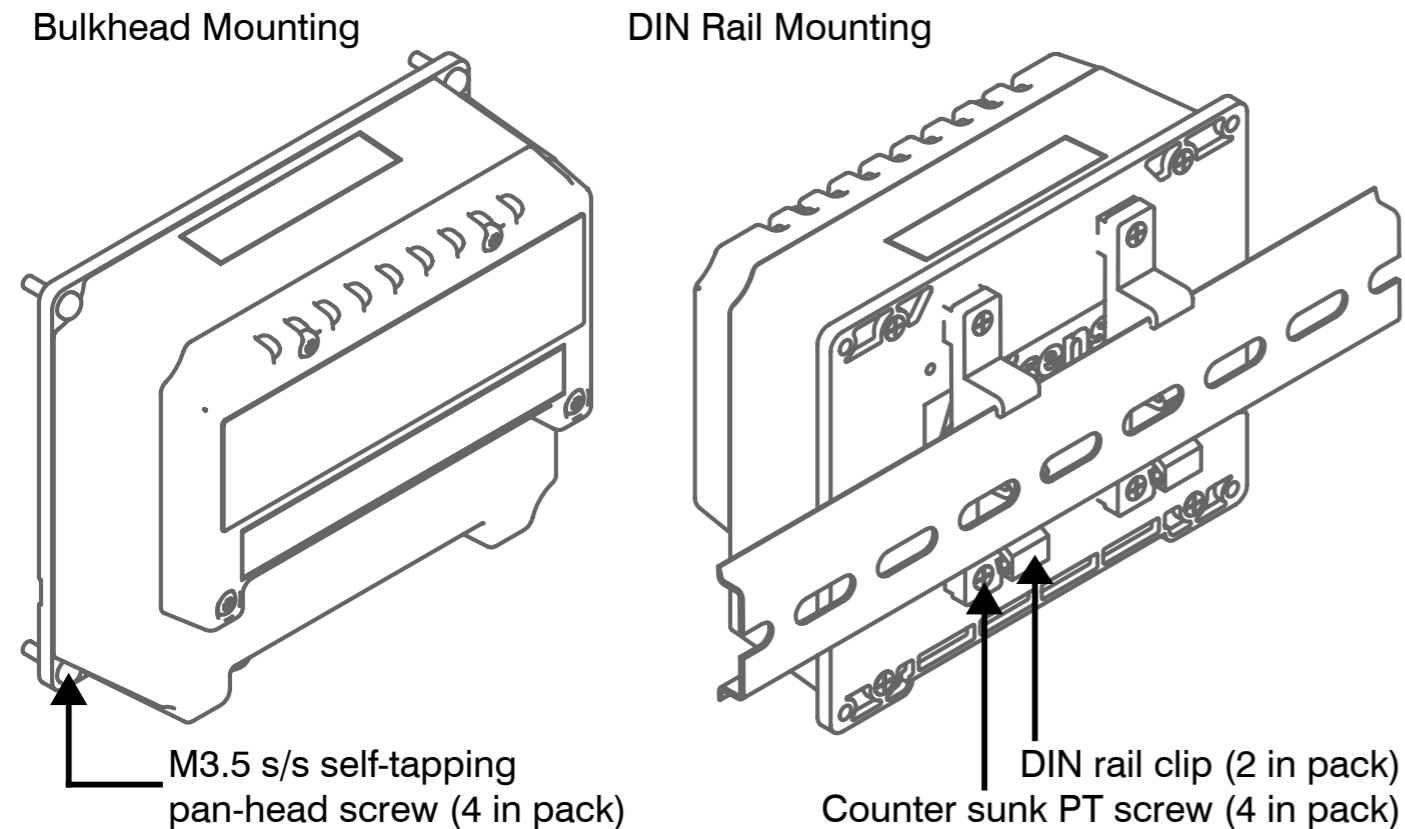

Connecting to an NMEA 2000 Network

The EMU-1 has a male Micro connector as specified by the NMEA 2000 standard. This allows the EMU-1 to be connected directly to an NMEA 2000 bus without complication. If you are using an alternative proprietary CAN bus network, a suitable adapter cable will be required. It is recommended that the manual for any proprietary CAN bus network devices be consulted to determine the suitability of connecting an NMEA 2000 device such as the EMU-1. A certified NMEA 2000 cable is recommended for connection to the EMU-1. Ensure that the drop cable is no longer than 6 meters from the NMEA 2000 backbone, see “[Table 1 - NMEA 2000 Cable Length Rules](#)”. The cable connector should be screwed securely to the EMU-1 connector to ensure reliable operation. It is recommended that the supplied NMEA 2000 dust cover is left in place until the EMU-1 is connected to the NMEA 2000 network.

There are a number of indicator LEDs that can be used to diagnose the NMEA 2000 connectivity. Please refer to, “[NMEA 2000 Power LED \(Red\)](#)”, “[NMEA 2000 Rx LED \(Green\)](#)” and “[NMEA 2000 Tx LED \(Orange\)](#)” on page 17

NMEA 2000 Networks

NMEA 2000 devices will only communicate with each other when connected to a powered and correctly terminated NMEA 2000 network. It is not enough to simply connect two NMEA 2000 devices directly together.

All networks need to be powered and terminated correctly to allow data to be transmitted reliably on the network. T-Pieces are needed to connect each device to the network. Additional cable lengths can be used between any of the connectors to extend the length of the network. Ensure the NMEA 2000 rules for cable length are adhered to, see “[Table 1 - NMEA 2000 Cable Length Rules](#)”.

NMEA 2000 Minimum Network Requirements

All NMEA 2000 networks require a 12V DC supply.

In addition, a correctly functioning network will require the following components :

- 1 x Power-T
- 2 x Terminating Resistors
- 2 x T-Pieces (one per connected device)
- 2 x NMEA 2000 Devices (such as the EMU-1)

All the required network parts can be supplied by Actisense www.actisense.com/A2K.

Table 1 - NMEA 2000 Cable Length Rules

Cable Type	Max Length
Per drop cable	6m
Sum of all drop cables	72m
Micro Backbone (terminator to terminator)	100m
Mini Backbone (terminator to terminator)	200m

Refer to “[Figure 6 - NMEA 2000 Minimum Network Requirements Diagram](#)” for an example network. Note that the diagram should not be used as an installation guide. NMEA 2000 networks should only be installed following the NMEA 0400 specification and all wiring should be in accordance with the regional code of practice for installations.

Figure 6 - NMEA 2000 Minimum Network Requirements Diagram

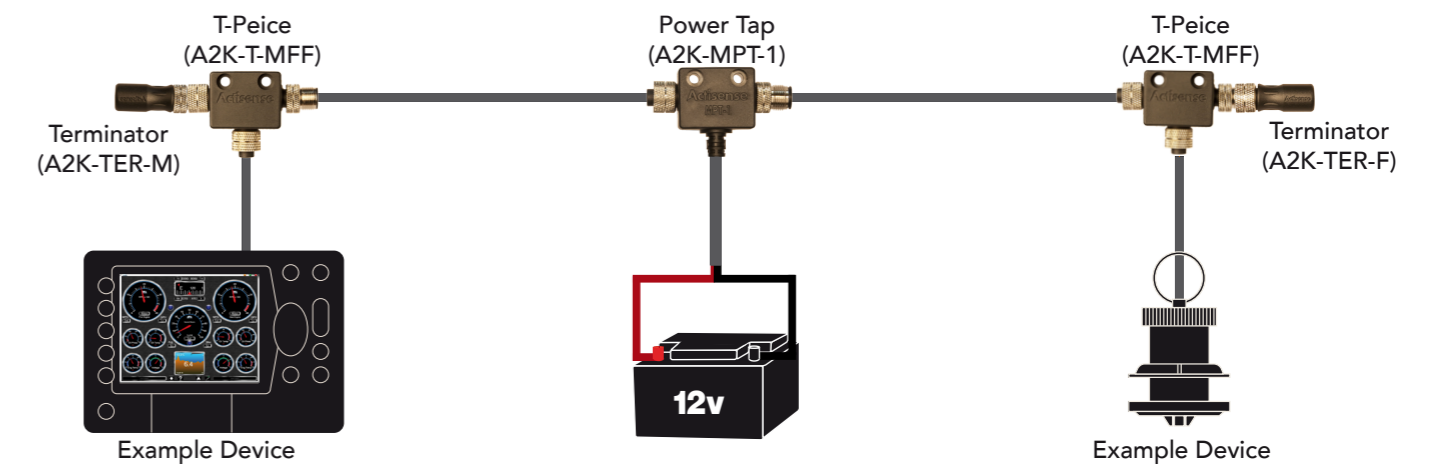

Gauge Input Connections

There are six Gauge inputs which are designed to be connected to existing engine senders (resistive type) either with or without the gauge connected. In the case where no gauge is connected the EMU-1 automatically provides a feed to the sender. A dual station sender must always have two gauges connected to it: the EMU-1 cannot replace one or both of those gauges. If it is required to remove one or both gauges, the dual station sender will need to be replaced with a single station sender.

Insulated Terminal Sender with Gauge

“Figure 7 - Gauge Input Connection Examples” G1 Input:

- The gauge power connection is connected to the same positive voltage supply as the EMU-1.
- The gauge ground connection is connected to the same ground as the EMU-1.
- The gauge signal connection is connected to the sender signal line.
- The sender return connection is connected to the same ground as the EMU-1.
- The EMU-1 Gauge input is connected to the gauge signal line, typically with a cable run that does not exceed 2 metres with a minimum 0.5mm wire diameter (24 AWG).

Insulated Terminal Sender without Gauge

“Figure 7 - Gauge Input Connection Examples” G2 Input:

- The senders return connection is connected to the same ground as the EMU-1.
- The EMU-1 Gauge input is connected to the sender signal line, typically with a cable run that does not exceed 2 metres with a minimum 0.5mm wire diameter (24 AWG).

Standard Grounded Sender with Gauge

“Figure 7 - Gauge Input Connection Examples” G4 Input:

- The gauge power connection is connected to the same positive voltage supply as the EMU-1.
- The gauge ground connection is connected to the same ground as the EMU-1.
- The gauge signal connection is connected to the sender signal line.
- The sender chassis is connected to the same ground as the EMU-1.
- The EMU-1 Gauge input is connected to the gauge signal line, typically with a cable run that does not exceed 2 metres with a minimum 0.5mm wire diameter (24 AWG).

Standard Grounded Sender without Gauge

“Figure 7 - Gauge Input Connection Examples” G3 Input:

- The sender chassis is connected to the same ground as the EMU-1.
- The EMU-1 Gauge input is connected to the sender signal line, typically with a cable run that does not exceed 2 metres with a minimum 0.5mm wire diameter (24 AWG).

Note: The examples given are not limited to the input they are shown with. E.g. the G1 Input example can also be connected to any of the other Gauge inputs. Each input will accept any of the gauge / sender examples described.

Note: Wire colours are for reference only

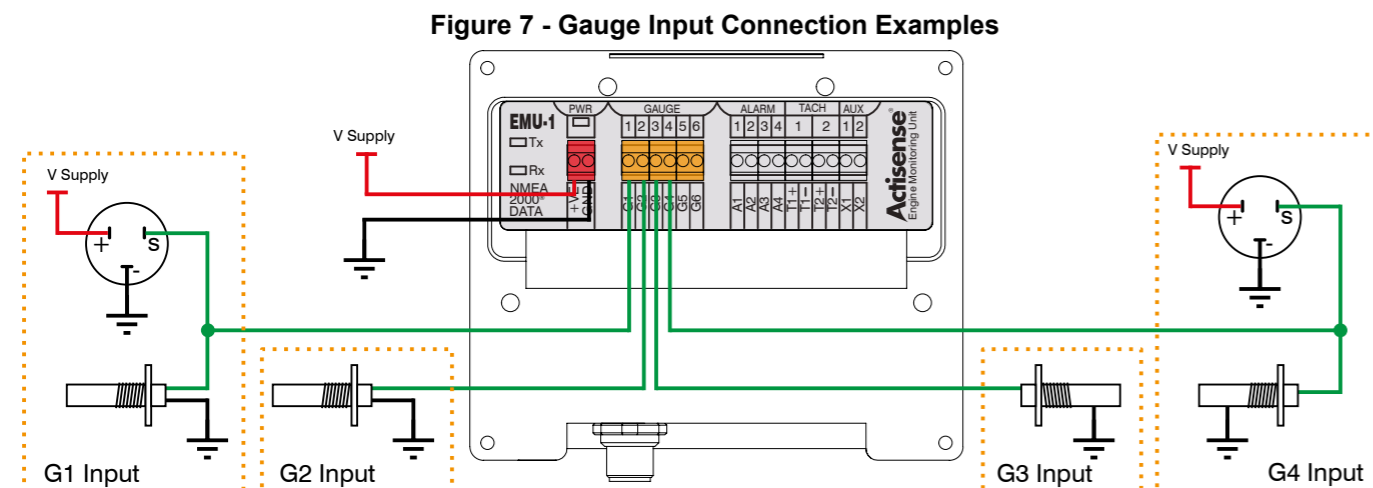

Alarm Input Connections

There are four Alarm inputs which are designed to be connected to existing alarm type switches. The EMU-1 can be used with or without the alarm indicator (e.g. lamp or buzzer) connected. If there is no alarm indicator, a suitable resistor can be used in its place. For 12 V supplies it is recommended to use a 1 kΩ, ¼ W resistor, for 24 V supplies it is recommended to use a 1 kΩ, 1 W resistor. Some alarm switches are incorporated into their relevant sender and are also suitable to connect to the EMU-1.

There are several different combinations of switch type and wiring method that the EMU-1 Alarm inputs are compatible with.

Supported Switch and Installation Types

- Normally Open switches (see Figure 8 Examples A1 and A4).
- Normally Closed switches (see Figure 8 Examples A2 and A3).
- Active High (see Figure 8 Examples A3 and A4).
- Active Low (see Figure 8 Examples A1 and A2).

Critical Circuit Requirements

- The switch circuits positive supply is the same as the supply used to power the EMU-1.
- The switch circuits negative supply (ground) is the same as the EMU-1 power ground.
- The switch circuit has a load (e.g. buzzer, lamp or resistor) in series with the switch between the positive supply and ground.
- The EMU-1 Alarm input is connected between the switch and the load (e.g. buzzer, lamp or resistor).

Additional Information

- If the EMU-1 is connected at the switch, the cable run should not typically exceed 2 metres.
- If the EMU-1 is connected at the buzzer or lamp, the cable run should not typically exceed 2 metres.
- If replacing the buzzer or lamp with a resistor this should be done as near to the EMU-1 as possible, in this case the cable run should not typically exceed 2 metres.

Please refer to the examples shown in “Figure 8 - Alarm Input Connection Examples”

Note: The examples given are not limited to the input they are shown with. E.g. the A1 Input example can also be connected to any of the other Alarm inputs. Each input will accept any of the switch and installation types listed above. Each input will require the type of installation to be selected using the configuration tool provided.

Figure 8 - Alarm Input Connection Examples

Note: Wire colours are for reference only

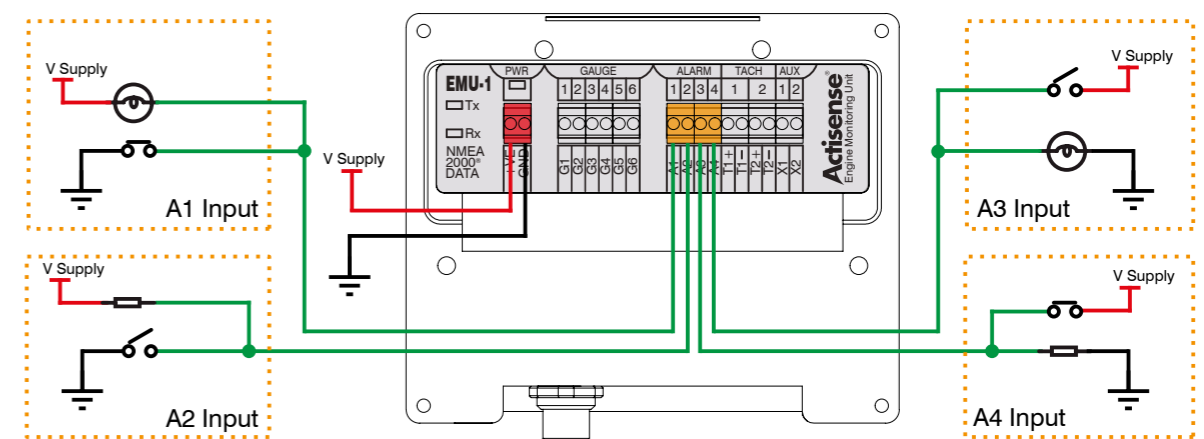

Tacho Input Connections

Figure 9 - Tacho Input Connections

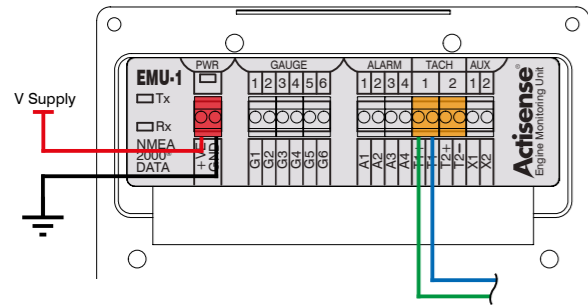

There are two Tacho inputs which are designed to be connected to existing engine senders either with or without the gauge connected.

The Tacho inputs must be calibrated in the configuration tool. The Pulses per Revolution (PPR) must be entered to allow the correct RPM to be calculated by the EMU-1.

There are several different sender options that can be used to generate NMEA 2000 RPM data. Each supported type is listed below along with the information required to configure the input using the configuration tool.

Figure 10

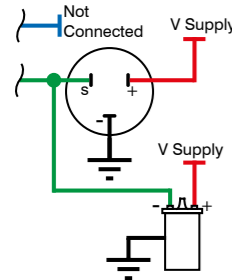

Ignition Coil

- Connect the negative connection of the ignition coil to the positive Tacho input of the EMU-1.
- The negative Tacho input of the EMU-1 should be left unconnected.
- Refer to the connection in **“Figure 9 - Tacho Input Connections”** and **“Figure 10”**.
- For calibration the PPR or the number of cylinders will need to be entered in the configuration tool.

Figure 11

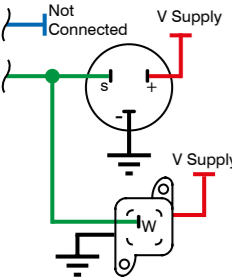

Alternator

- Connect the Tacho (AC Tap) or ‘W’ connection of the alternator to the positive Tacho input of the EMU-1.
- The negative Tacho input of the EMU-1 should be left unconnected.
- Refer to the connection in **“Figure 9 - Tacho Input Connections”** and **“Figure 11”**.
- For calibration the PPR or the number of poles and the pulley ratio will need to be entered in the configuration tool.

Figure 12

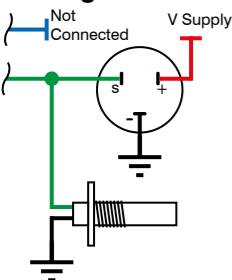

Hall Effect and Electronic Pulse Senders

- Connect the signal line of the sender to the positive Tacho input on the EMU-1.
- The negative Tacho input of the EMU-1 should be left unconnected.
- Refer to the connection in **“Figure 9 - Tacho Input Connections”** and **“Figure 12”**.
- For calibration the PPR or the number of teeth on the fly wheel will need to be entered in the configuration tool.

Figure 13

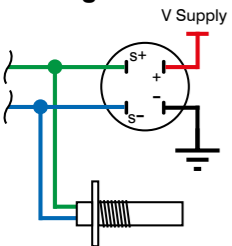

Inductive Senders

- Connect the positive signal line from the sender to the positive Tacho input of the EMU-1.
- Connect the negative signal line from the sender to the negative Tacho input of the EMU-1.
- Refer to the connections in **“Figure 9 - Tacho Input Connections”** and **“Figure 13”**.
- If the negative signal line is not available, the negative Tacho input of the EMU-1 should be left unconnected, and the sender should be connected to the same ground as the EMU-1.
- Refer to the connection in **“Figure 9 - Tacho Input Connections”** and **“Figure 12”**.
- For calibration the PPR or the number of teeth on the fly wheel will need to be entered in the configuration tool.

Calculating Tacho PPR

The EMU-1 configuration tool allows the “ratio” to be configured. This ratio is usually referred to as the PPR (Pulses Per Revolution). The engine manufacturer will usually be able to supply this ratio so it should not need to be calculated.

For an Alternator (“W”, “R” or “AC”) terminal connection it can be calculated from:
 $PPR = (\text{Crank pulley diameter} / \text{Alternator pulley diameter}) \times (\text{No. of poles in Alternator} / 2)$

For an inductive sender it is derived from the number of teeth on the flywheel:
 $PPR = \text{No. of teeth on flywheel}$

For an ignition coil it can normally be calculated from
 $PPR = (\text{No. of cylinders} \times 2) / (\text{No. of strokes} \times \text{No. of ignition coils})$

Auxiliary Input Connections

There are two Auxiliary inputs which are included for future expansion. Currently these inputs are disabled.

Battery Voltage Sensing

The EMU-1 automatically measures the voltage across it’s supply inputs (marked ‘PWR +VE’ and ‘PWR GND’). This value is provided in the battery status PGN.

Power Requirements

Connecting the Power

- Refer to **“Warning 3: Installation Code of Practice”** on page 7.
- The EMU-1 should be powered from the same supply as the gauges / senders.
- The EMU-1 requires a power source providing between 9 and 35 Volts DC.
- Connect the positive supply wire to the ‘PWR +VE’ screw terminal of the EMU-1.
- Connect the negative / ground supply wire to the ‘PWR GND’ screw terminal of the EMU-1.
- Once connected, turn on the supply. For details on the Power indicator, refer to **“EMU-1 Power LED (Blue)”** on page 17.

Grounding Requirements

All measurements are taken relative to the ground power pin of the EMU-1. For both safety and accurate measurements, it is important to understand the vessels grounding to ensure the EMU-1 is grounded at the appropriate place. The EMU-1 should always be connected to a good ground connection point which is not susceptible to ground noise. It is important that the EMU-1 ground is the same as the engine ground.

The EMU-1 should only be used with standard negative ground DC systems.

When the EMU-1 is connected to senders only (no gauges are connected), it is important that the EMU-1 ground is the same as the engine ground.

Dual Engine Power Supply

When monitoring two engines using a single EMU-1, both engines and the EMU-1 must share the same power supply if the gauges are to remain in circuit. If a separate power supply must be used for each engine, either a separate EMU-1 is required for each engine or the gauges will need to be removed for the EMU-1 to correctly monitor the sensors of both engines.

Factory Configuration

The configuration loaded into the EMU-1 is detailed in “[Table 2 - Default EMU-1 Input Configuration](#)”. Connecting to any other type of sender without configuring the unit is likely to cause incorrect data to be output to the NMEA 2000 bus. See “[Configuring the EMU-1](#)” for how to configure the unit.

Table 2 - Default EMU-1 Input Configuration

EMU-1 Input	Gauge
G1 - Gauge 1	Temperature Sender 287 - 22Ω VDO (40 to 120°C) Euro
G2 - Gauge 2	Oil Pressure Sender, 10 - 180Ω, VDO (0 to 80 PSI / 0 to 5 Bar) Euro
G3 - Gauge 3	Disabled without configuration
G4 - Gauge 4	Disabled without configuration
G5 - Gauge 5	Disabled without configuration
G6 - Gauge 6	Disabled without configuration
A1 - Alarm 1	Temperature Switch (High Temp Alarm), Normally Open (V Negative)
A2 - Alarm 2	Pressure Switch (Low Oil Pressure Alarm), Normally Open (V Negative)
A3 - Alarm 3	Disabled without configuration
A4 - Alarm 4	Disabled without configuration
T1 - Tacho 1	Alternator, “W” Connection - 11.78 Pulses Per Revolution
T2 - Tacho 2	Disabled without configuration
X1 - Aux 1	Disabled without configuration
X2 - Aux 2	Disabled without configuration

Configuring the EMU-1

Configuration Requirements

To configure the EMU-1 the following is required:

- A working NMEA 2000 network.
- An NGT-1 (either the ISO or USB variant).
- A PC running the Actisense EMU-1 Configuration Tool. The tool is provided on the CD but it is recommended that the latest version is downloaded from www.actisense.com/EMU-1/Downloads.
- Information about the senders/gauges being connected. **Note:** For the Tacho inputs additional information will be needed, see “[Tacho Input Connections](#)” on page 14.

All instructions for configuring the EMU-1 can be found in the help menu of the configuration tool software.

Troubleshooting Guide

The majority of issues can be resolved by confirming the EMU-1 is connected correctly, refer to the LED descriptions below to confirm the power and NMEA 2000 connections are operational. Once these connections are confirmed, the analogue connections and configuration need to be checked. Refer to “[Configuring the EMU-1](#)” on page 16.

LED Indicators

EMU-1 Power LED (Blue)

There is a power LED located above the power supply terminal connectors which is visible through the connector cover. The LED flashes blue to indicate power and denotes the active mode of the unit. The LED flashes 5 times a second when in Bootloader mode. This should be seen for the first 2 seconds following power on and when ‘connected’ to ActiPatch for updating. If the LED continues to flash 5 times a second after initial power on, the unit no longer has its Firmware. In this case, connect the EMU-1 to Actipatch and reinstall the Firmware. The LED flashes once a second when in Normal mode, this indicates the Firmware is running and the EMU-1 can be configured and will connect to an NMEA 2000 network when available.

NMEA 2000 Power LED (Red)

There is a red LED located near to the NMEA 2000 connector which is visible through the main body of the EMU-1. When the EMU-1 is connected to an NMEA 2000 network with a suitable power supply the LED will light. This does not indicate that the bus is correctly terminated or that there is any data on the network. The LED will light regardless of whether the EMU-1 has power to the terminal connections. The EMU-1 requires power on both the terminals and the NMEA 2000 bus to function correctly. These two power supplies do not need to be the same or have the same ground. The NMEA 2000 bus and EMU-1 power are isolated from each other within the EMU-1 as required in the NMEA 2000 specification.

NMEA 2000 Rx LED (Green)

There is an NMEA 2000 data receive LED located to the left of the terminal connectors which is visible through the connector cover. The LED flashes green on reception of an NMEA 2000 PGN message that is in the PGN list, see “[Table 3 - NMEA 2000 PGN List](#)” on page 18.

As this is a small list, a blank LED should not be interpreted as a failure to connect to the NMEA 2000 bus without confirming that compatible PGNs are present on the bus.

NMEA 2000 Tx LED (Orange)

There is an NMEA 2000 data transmit LED located to the left of the terminal connectors which is visible through the connector cover. The LED flashes orange on transmission of an NMEA 2000 PGN message.

Technical Support and the Returns Procedure

All installation instructions and any warnings contained in this manual must be applied before contacting Actisense technical support. If the troubleshooting guide did not help resolve the problem and an error persists, please contact Actisense technical support to help trace the issue before considering the return of the product. If Actisense support concludes that the EMU-1 unit should be returned to Actisense a Returns Number will be issued by the support engineer.

The Returns Number must be clearly visible on both the external packaging and any documentation returned with the product. Any returns sent without a Returns Number will incur a delay in being processed and a possible charge.

Supported NMEA 2000 PGNs

Table 3 - NMEA 2000 PGN List

PGN	PGN Name	Rx	Tx	Data Tx Rate
59392	ISO Acknowledge	YES	YES	
59904	ISO Request	YES	NO	
60160	ISO Transport Protocol, Data Transfer	YES	YES	
60416	ISO Transport Protocol, Connection Management	YES	YES	
60928	ISO Address Claim	YES	YES	
65240	ISO Commanded Address	YES	NO	
126208	NMEA Request/Command/Acknowledgement	YES	YES	
126464	Rx & Tx PGN Lists	NO	YES	
126720	Proprietary Fast-Packet	YES	YES	
126996	Product Information	NO	YES	
126998	Configuration Information	NO	YES	
127488	Engine Parameters, Rapid Update	NO	YES	0.1 seconds
127489	Engine Parameters, Dynamic	NO	YES	0.5 seconds
127493	Transmission Parameters, Dynamic *	NO	YES	0.5 seconds
127505	Fluid Level *	NO	YES	2.5 seconds
127508	Battery Status	NO	YES	1.5 seconds

* Not enabled by default / Enabled by EMU Config Tool

Dimension Diagram

Figure 14 - Dimension Diagram

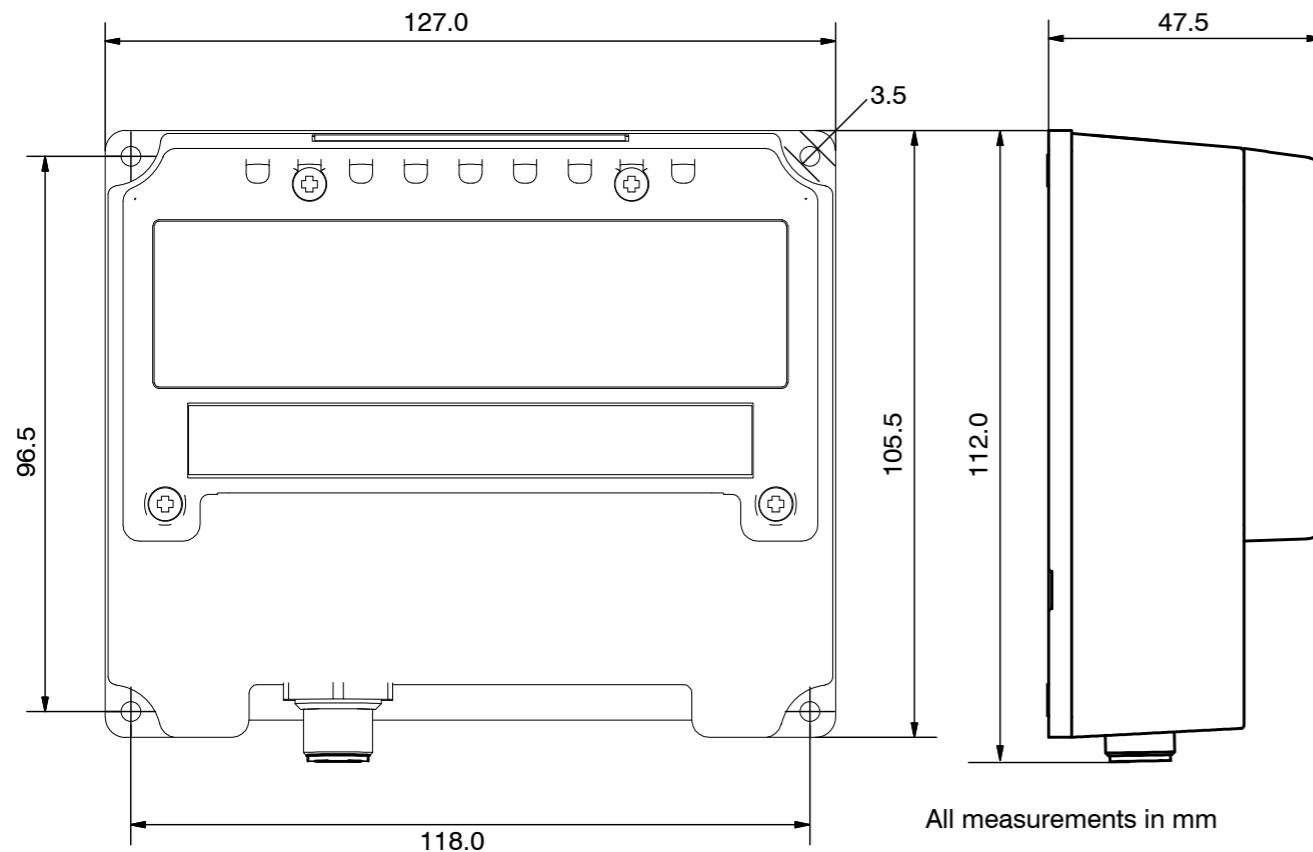

Specifications

Table 4 - Specification Table

Power Supply	
Supply Voltage	9 to 35V DC
Supply Current	Typically < 25mA @ 12V DC
Supply Protection	Continuous reverse polarity protection and load dump protection (meets SAE J1113)
Supply Connector	Pluggable 2-way screw terminal, 3.5mm pitch
Supply Voltage (NMEA 2000 port)	9 to 29V DC
Supply Current (NMEA 2000 Port)	< 20mA @ 12V DC from NMEA 2000 bus
Load Equivalence Number (NMEA 2000 Port)	1 LEN
Supply Protection (NMEA 2000 Port)	Continuous reverse polarity protection and overvoltage protection to 40V
NMEA 2000 Port - In/Out	
Compatibility	NMEA 2000 compatible
Galvanic Isolation	2500V input to ground
Speed / Baud Rate	250kbps
NMEA 2000 connector	M12 male (A coded) connector
Gauge Inputs	
Voltage Range	0 to 35V DC
Input Impedance	> 50kΩ
Sender Feed	0, 4 or 18mA
Accuracy	<= 2%
Input Connector	Pluggable 6-way screw terminal, 3.5mm pitch
Input Protection	Overvoltage protection to ±40V
Alarm Inputs	
Voltage Range	0 to 37V DC
Input Impedance	> 50kΩ
Threshold Voltage	Configurable, default is 5V
Alarm Polarity	Configurable, default is alarm on low input
Accuracy	<= 2%
Input Connector	Pluggable 4-way screw terminal, 3.5mm pitch
Input Protection	Overvoltage protection to ±40V
Tacho Inputs	
Voltage Range	±3 to ±60V
Input Impedance	> 100kΩ to ground
Input Pulse Range	4 to 50,000Hz
Accuracy	<= 1%
Sender Compatibility	Ignition coil, alternator ("W", "R" or "AC") terminal, hall effect, VR or inductive sender
Threshold	Automatically adjusts to signal level
Input Connector	Pluggable 4-way screw terminal, 3.5mm pitch
Input Protection	Can withstand an ignition pulse to ±500V
Engine Log	
Engine Hours	2 separate engine hour logs internally connected to the tacho inputs. Hours are logged when RPM is present, stored in non-volatile memory
Mechanical	
Housing Material	Polycarbonate
Protective Lid Material	Polycarbonate
Sealing Materials	Expanded silicone foam gasket, closed cell polyurethane splash guard and ePTFE waterproof vent
Dimensions	127mm (L) x 112mm (W) x 48mm (H)
Weight	250g
Mounting	4 x 3.5mm lugs to allow panel mount with self tapping s/s screws (included), optional DIN Rail mount available on request
Approvals and Certifications	
Fully NMEA 2000 Certified	
EMC	EN 60945 (sections 9 & 10)
Environmental Protection	IP66 (PCB housing)
Operating Temperature	-20°C to +55°C
Storage Temperature	-30°C to +70°C
Relative Humidity	0 to 93% RH
Guarantee	3 years

All specifications are taken with reference to an ambient temperature (TA) of +25°C.

EMU-1 Product Order Codes

Product Code	Product Description
EMU-1-BAS	Engine Monitoring Unit, Analogue to NMEA 2000, standard configuration
Product Code	Accessory Description
NGT-1-USB	NMEA 2000 PC interface, standard version with USB
NGT-1-ISO	NMEA 2000 PC interface, specialist version with RS422 serial
DIN-KIT-1	Kit of 2 clips & 4 screws. Use with EMU-1-BAS & NBF-3-BAS on top hat (EN 50 022) or G section (EN 50 035) rails
STNG-A06045	SeaTalkNG to NMEA 2000 adaptor cable (drop).

Actisense®

Active Research Ltd
Unit 5, Wessex Trade Centre
Ringwood Road
Poole, Dorset
UK, BH12 3PF



Telephone: +44 (0)1202 746682
Email: sales@actisense.com
Web: www.actisense.com