

Gusher® 30

GUSHER 30 is our largest capacity manual bilge pump. Manufactured by hand using high grade materials based on more than 60 years experience. The heavy duty Gusher 30 is ideal when long term durability and high performance is vital.

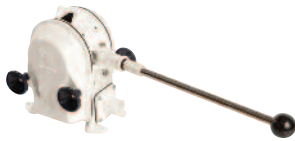

Thru Deck
BP3020



On Bulkhead
BP3010

Long term reliability
fully protected diaphragms

Product Code: BP3000



Ease of use
easy grip handle

Ease of operation
extra long handle

Robust design
corrosion resistant, powder-coated,
die-cast aluminium alloy

Simple plumbing
38mm (1½")
hose connections

Efficiency
high capacity double acting pump

Maximum Output - Delivering Over 117 ltrs (31 US Gals) Per Minute

- Efficient operation
 - Double acting pumps on both to and fro strokes
- Reliability
 - Twin diaphragms ensure pump continues working if one is damaged
- Durability
 - Powder coated diecast aluminium alloy
- Easily pumps oily bilge water
- 3 mounting options
 - Available for deck, bulkhead or underdeck mount

5 Year Warranty

Tips

It is important to ensure that a vented anti-syphon loop is incorporated in the system

Awards and Accreditations

- Pump accepted on some vessels for use as an emergency fire pump
- Suitable as a primary bilge pump on boats equal to or greater than 12 m (40ft) in accordance with ISO15083



Life Boats Approval

- Approved by Lloyds (MCA) and USCG

COMPLETE YOUR SYSTEM

Whale high quality bilge accessories including non-return valves, elbows and Y pieces see page 48 - 51

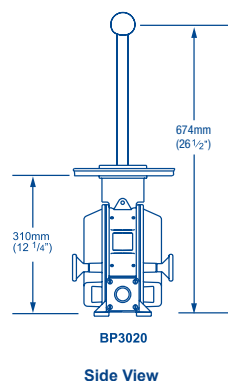
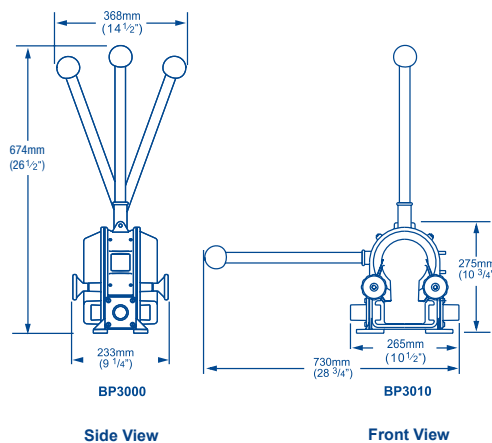

Product Information

Model Specifications

Model	On Deck BP3000	On Bulkhead BP3010	Thru Deck Only BP3020
Hose Connections	38 mm (1 1/2") Hose Connections		
Weight	5.05 kg (11.1 lbs)		5.9 kg (13 lbs)
Materials	Pump Body: Marine Grade LM6 Aluminium Alloy (epoxy coated) Diaphragm: Neoprene, Bushes: Acetal, Handwheels: Nylon Fasteners: Stainless Steel		
Materials In Contact With Fluid	Marine Grade LM6 Aluminium Alloy (epoxy coated) Nitrile* Stainless Steel		
Service Kit	AK3051 - Service Kit for Gusher® 30 Contains: Diaphragms, Valves, Gasket AS3725 - Gaiter Kit - for use with BP3020 AS3016 - Handwheel / stud kit AS3015 - Lever Assembly		
Accessories	AS3095 - Spare Handle DP3804 Deckplate, AS3020 Deckplate Conversion Kit		
Maximum Suction Lift		4 m (13.5 ft)	
Maximum Discharge Head		4 m (13.5 ft)	

Performance Data

	BP3000 / BP3010 BP3020	BP3000 / BP3010 BP3020	BP3000 / BP3010 BP3020
Suction Lift	0	1 m (3 ft)	2 m (6 ft)
Discharge Head	0.5 m (1.5 ft)	0.5 m (1.5 ft)	0.5 m (1.5 ft)
45 Strokes per Minute	75 ltrs (20 US gals)	71 ltrs (19 US gals)	71 ltrs (19 US gals)
70 Strokes per Minute	117 ltrs (31 US gals)	111 ltrs (29 US gals)	111 ltrs (29 US gals)

Note: These specifications are retail items only.

For details of our bulk pack range for boat builders and wholesalers - contact Whale Support.

* If Neoprene diaphragm require please contact Whale Support