

Tron 60S/GPS EPIRB

Float-free and manual bracket

User manual



Abbreviations

BIT	Short form of Binary Digit. The smallest element of data in a binary-coded value
BPS	Bits Per Second
COSPAS	COsmicheskaya Sistyema Poiska Avariynich Sudov
EPIRB	Emergency Position Indicating Radio Beacon
GPS	Global Positioning System
HRU	Hydrostatic Release Unit
IBRD	International 406MHz Beacon Registration Database
IEC	International Electrotechnical Commission
IMO	International Maritime Organization
ITU	International Telecommunication Union
LED	Light Emitting Diode
LUT	Local User Terminal (Ground station)
mAh	Milliamp hour
MCC	Mission Control Centre
MHz	Megahertz
NOAA	National Oceanic and Atmospheric Administration (USA)
RCC	Rescue Coordination Centre
SAR	Search and Rescue forces
SARSAT	Search and Rescue Satellite Aided Tracking System
SBM	Shore Based Maintenance
UIN	Unique Identifier Number
USCG	United States Coast Guard

Table of Contents

1	List of figures	6
2	List of tables.....	7
3	General	8
4	Standards.....	9
5	Product description	12
5.1	Product image	13
5.2	Cospas-Sarsat system description	14
5.2.1	Signal detection	14
5.2.1.1	Advantages of an included GPS	15
5.2.2	EPIRB registration	16
5.2.3	False alerts transmitted	17
6	Functional description	18
6.1	Tron 60S/GPS components.....	18
6.2	Main module	19
6.3	Antenna.....	19
6.4	Battery pack	19
6.5	Brackets.....	19
6.5.1	FB-60 float free bracket	19
6.5.2	MB-60 manual bracket	20
7	Installation.....	21
7.1	Brackets.....	21
7.1.1	Mounting the FB-60 float-free bracket	21
7.1.2	Mounting the MB-60 manual bracket.....	22
7.2	Replacing the battery.....	23
8	Operation instructions.....	23
8.1	Manual operation	24
8.1.1	Out of bracket	24
8.1.2	Stored in the FB-60 float free bracket.....	25
8.2	Automatic operation from the FB-60 float free bracket..	29
8.3	Wrist strap.....	30

9	Maintenance.....	31
9.1	Inspection.....	32
9.2	Testing.....	33
9.2.1	Self-test	33
9.2.1.1	Error codes (flashes)	34
9.2.2	Extended self-test (GPS test) (only Tron 60GPS).....	35
9.2.2.1	Error codes (beeps).....	36
10	Replacing the hydrostatic release unit (HRU).....	36
11	Test and maintenance records	40
12	Battery safety information	41
12.1	Handling and storage	41
12.1.1	Transportation	41
13	Technical specifications	42
13.1	Product specification	42
13.2	COSPAS-SARSAT transmitter.....	42
13.3	Navigation device (only Tron 60GPS)	43
13.4	Homing transmitter	43
13.5	Brackets.....	43
13.5.1	FB-60 Float-free bracket	43
13.5.2	MB-60 Manual bracket	43
14	Optional accessories.....	44
15	Spare parts.....	44
15.1	Counterfeit spare parts.....	44
16	Recycling and disposal	44
17	Warranty.....	44
18	Service	44
18.1	Service agents	45
19	Document revision log.....	46
20	Emergency instructions	47

1 List of figures

Figure 1 Image - Tron 60S/GPS	13
Figure 2 Illustration - signal detection	15
Figure 3 Illustration - Tron 60S/GPS components	18
Figure 4 Image - FB-60 float free bracket	20
Figure 5 Image - MB-60 manual bracket	20
Figure 6 Illustration - FB-60 float free bracket dimensions.....	22
Figure 7 Illustration - MB-60 manual bracket dimensions	23
Figure 8 Illustration - automatic operation of a FB-60 float free bracket....	30
Figure 9 Illustration - self-test.....	34
Figure 10 Emergency instructions overview	47

2 List of tables

Table 1 Satellites - LEOSAR & GEOSAR	16
Table 2 Tron 60S/GPS components	18
Table 3 Tron 60S/GPS maintenance requirements	32
Table 4 Tron 60S/GPS self-test error codes (flashes)	35
Table 5 Tron 60GPS GPS test error codes (beeps)	36

3 General

Jotron manufactures safety products designed for the search and rescue of human lives and property. For this product to be effective according to the design parameters, it is imperative that it is handled, maintained, serviced and stowed in accordance with this manual.

All information contained within this manual has been verified and is to Jotron's knowledge correct. Jotron reserves the right to make changes to any product(s) or module(s) described herein to improve design, function or reliability, without further notice.



Jotron is not liable and cannot be held responsible for any injury or damages caused directly or indirectly by an error or omission of information, incorrect or misuse, breach of procedures or failure of any specific component or part of this product.

Jotron documentation can be downloaded from jotron.com.

4 Standards

Jotron declares that this this product is compliant with IMO and SOLAS regulations and both MED and RoHS directives.

A copy of the declaration of conformity can be downloaded from jotron.com.

The Tron 60S/GPS has been verified, tested and meets the following product standards:

IEC 61097-2 Ed. 3.0	Global maritime distress and safety systems (GMDSS) Part 2: Cospas-Sarsat EPIRB – Satellite emergency position indicating radio beacon operating on 406 MHz – Operational and performance requirements, methods of testing and required test results.
IEC 60945 Ed. 4.0 including IEC 608945 Corrigendum 1	Corrigendum 1 – Maritime navigation and radiocommunication equipment and systems – General requirements – Methods of testing and required results.
EN 300 066 v.1.3.1	Electromagnetic compatibility and radio spectrum matters (ERM); Float-free maritime satellite – EPIRB operating in the 406,9 MHz to 406,1 MHz frequency band; technical characteristics and methods of measurement
IEC 63000:2016	Technical documentation for the assessment of electrical and electronic products with respect to the restrictions of hazardous substances
ISO 14001	Environmental management systems
ISO 9001	Quality management principles

In accordance with SOLAS regulations, the following controls must be followed:

<p>IV/15.9.2 of SOLAS 1974, in accordance with MSC/Circ. 1039 guidelines</p>	<p>SOLAS regulation for Shore Based Maintenance (SBM) of Satellite EPIRBs within 5 years if: Passenger ships (> 12 passengers) and cargo ships (> 300GT) engaged in international voyages, shall perform SBM as follows: Latest by the date of the EPIRB label with this text, or the battery Label, whichever is first. And when this EPIRB becomes due for SBM in accordance with national requirements.</p>
<p>IV/15.9.2 of SOLAS 1974 as amended to in accordance with MSC/Circ.1039 guidelines</p>	<p>SOLAS regulation for shore-based maintenance of satellite EPIRBs within 5 years, or by the date of battery expiry, whichever is first. As it applies to maintenance (servicing and tested) for vessel that requires GMDSS compliant equipment.</p>
<p>SOLAS Chapter IV reg. 15.9.2 and IMO MSC. Circ. 1039</p>	<p>Regarding battery change. This must be completed at a Jotron SBM authorized location and it must also be approved by the VDR manufacturer. The interval is dependent on the flag-state administration. If neither international nor national regulations apply to the EPIRB then the battery may be changed by an authorized Jotron partner/distributor.</p>
<p>IMO - MSC/Circ.1040 & rev.1 as required by SOLAS IV/15.9</p>	<p>Regarding yearly testing of 406 MHz on satellite EPIRBs. Rev.1 requires that annual testing be performed by an authorized radio-surveyor or an authorized person who is trained and certified by Jotron.</p>

IMO MSC.1/Circ.1222	Regarding an additional yearly testing requirement for the Tron 40VDR float free capsule.
IMO COMSAR/Circ. 32 (latest revision)	Correct installation and storage of this product.

5 Product description

The Tron 60S and Tron 60GPS are Emergency Position Indicating Radio Beacons (EPIRB), the only difference between them is that the Tron 60S does not include a GPS.

The purpose of the Tron 60S/GPS is to send a primary alarm to the search and rescue authorities. These EPIRB's send a distress signal when activated, transmitting the ID of the ship.

The Tron 60S and Tron 60GPS are buoyant and activate automatically when immersed in water. The EPIRB operates both automatically and manually.

There are two mounting brackets available for use with both the Tron 60S and Tron 60GPS, a float free bracket and a manual bracket. Both brackets are specially designed with an internal safety switch (water detectors), that prevents the EPIRB from inadvertently being activated by moisture or water spray when placed in the bracket.

The Tron 60S/GPS includes the following components:

- Cospas-Sarsat emergency EPIRB
- GPS (Tron 60GPS only)

5.1 Product image



Figure 1 Image - Tron 60S/GPS

5.2 Cospas-Sarsat system description

Cospas is an acronym for the Russian words *Cosmicheskaya Sistyema Poiska Avaryynich Sudov*, which means “Space System for the Search of Vessels in Distress”. The Cospas-Sarsat system was introduced in 1982 as a worldwide search and rescue system with the help of satellites covering the earth’s surface. Between 1982 and 2018 alone this system has aided in rescuing at least 48,738 individuals in 14,531 search and rescue situations. Currently, the system consists of 5 functional satellites in a polar orbit constellation, these satellites cover the entire earth’s surface and receive the emergency signal from the 406 MHz transmitter within the Tron 60S/GPS, more polar orbiting satellites will be available in the future, giving a faster location and rescue time.

In addition, several geostationary satellites are equipped with a 406 MHz transponder. These satellites are not able to locate the Tron 60S/GPS but will give an early warning to the rescue forces, minimizing the time from an emergency occurs till the rescue forces are at the site.

Each EPIRB in the system is programmed with its own unique code, therefore, it is vital that the ships data supplied to the dealer upon purchase or when the Tron 60S/GPS was obtained is correct. It is also important that the EPIRB is registered in the database for each country. This database is normally located in the same country where the ship is registered.

5.2.1 Signal detection

When a Tron 60S/GPS is activated (manually or automatically) it transmits an analogue signal on the 121.5 MHz frequency and digital signal on the 406.037 MHz frequency. After the Tron 60S/GPS is activated, the next passing satellite will detect the transmitted signal and relay it to an antenna at a local user terminal (LUT) ground station.

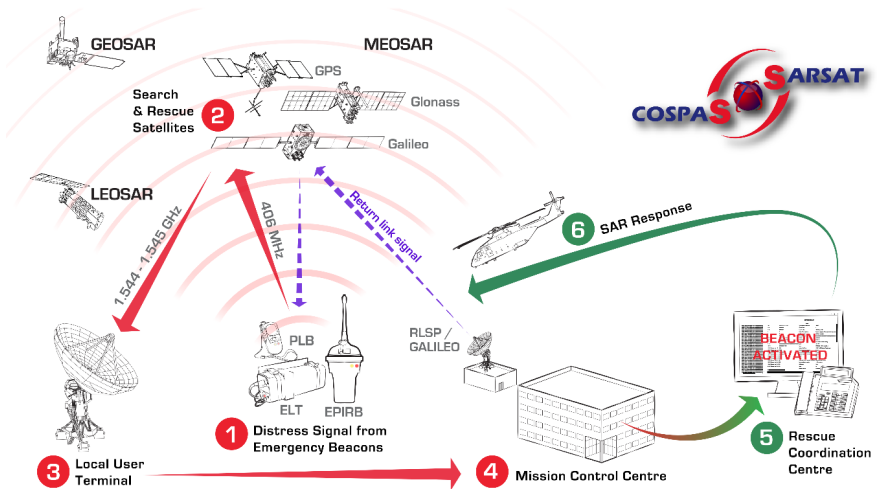

Figure 2 Illustration - signal detection

5.2.1.1 Advantages of an included GPS

This product has been designed to operate with the Cospas-Sarsat system. With the inclusion of a GPS, this EPIRB enhances lifesaving capabilities. The GPS position is updated every 5 minutes.

Below is a comparison between Tron 60S and Tron 60GPS depending on the detecting satellite, polar orbiting or geostationary.

	Polar orbiting satellites (LEOSAR)	Geostationary satellites (GEOSAR)
Tron 60S	Delayed alert (<90 min) Position by Doppler (5km)	Immediate alert (<5 min) NO position
Tron 60GPS (MMSI Standard Location Protocol Long)	Delayed alert (<90 min) Position by GPS (120m)	Immediate alert (<5 min) Position by GPS (120m)

Longer delay,
Low resolution position

Fast alert and accurate
position

Table 1 Satellites - LEOSAR & GEOSAR

5.2.2 EPIRB registration

Normally the Mission Control Centre (MCC) will contact the vessel, or the contact person registered in the shipping register and/or EPIRB register (ship owner, family member etc.) before alerting the Rescue Coordination Centre (RCC). This is to determine if the alarm from the EPIRB is a false alarm and a rescue operation can be avoided. Hence, it is important that the data in the shipping register and/or EPIRB register is correct.

Register the beacon with the national authority associated with the country code in the hexadecimal identification (15 Hex ID) of the beacon. Register online with the Cospas-Sarsat IBRD, if the country does not provide a registration facility and the country has allowed direct registration in the IBRD: www.406registration.com

If the country operates a national beacon registry, obtain a point of contact at www.cospas-sarsat.org (review C/S S.007 Cospas-Sarsat Handbook of Beacon Regulations).

Suggested EPIRB registration links:

USA: <http://beaconregistration.noaa.gov> and UK: <http://www.mcga.gov.uk>
(search - EPIRB registration)

USA registration card:

Suggested registration link: <http://beaconregistration.noaa.gov>

It can also be registration via mail or fax. Downloadable forms are available from the website.

The Emergency Contact information and telephone number must be accurate as it is what will be used to validate an alert. The United States Coast Guard (USCG) will only launch an immediate rescue if the beacon registration and approximate location details can be confirmed. Delays will occur whilst further alerts from the same source are received and verified.

Registration address:

NOAA/SARSAT Beacon Registration

NSOF, E/SP053

1315 East West Hwy

Silver Spring, MD 20910

5.2.3 False alerts transmitted

If for any reason an inadvertent activation or false alarm occur, you must report it to the nearest search and rescue authorities. The following information must be reported:

- 15-digit unique identifier number (UIN) on the beacon label.
- Date and time of activation (including time zone).
- Cause and duration of the activation.
- Location of the beacon at the time of activation.

To report a false alarm in the United States, contact the US Coast Guard at 1-855-406-USCG (8724)

To report a false alarm outside of the US, contact the national authority where the beacon is registered.

6 Functional description

6.1 Tron 60S/GPS components

An overview of the components.



Figure 3 Illustration - Tron 60S/GPS components

Item no.	Item
1	Top light
2	Antenna
3	Safety ring
4	Main switch
5	Sealing
6	Water detectors
7	Lower housing

Table 2 Tron 60S/GPS components

6.2 Main module

The main board includes all electronic circuitry and the main switch.

6.3 Antenna

The antenna for the Tron 60S/GPS is omnidirectional and includes a LED flash at the top.

6.4 Battery pack

The battery pack supplies the EPIRB with power to keep the EPIRB transmitter active for 48 hours when activated, and for test sequences. The battery pack is integrated within the product.

Two water detectors are mounted in the battery pack. These two metal contacts are located one on each side of the lower housing.



IMPORTANT

Do not touch the metal contacts as this can be detected as water and activate the EPIRB.

6.5 Brackets

The following two brackets are available for mounting the Tron 60S/GPS:

- FB-60 float free bracket
- MB-60 manual bracket

6.5.1 FB-60 float free bracket

The FB-60 float free bracket is a covered bracket with a hydrostatic release unit (HRU). The HRU releases the Tron 60S/GPS if the bracket is submerged to a depth of 2-4 meters when a ship is sinking. When the Tron 60S/GPS is mounted in the FB-60, it operates as an automatic float free unit.



Figure 4 Image - FB-60 float free bracket

6.5.2 MB-60 manual bracket

The MB-60 manual bracket is a simple bracket and can be used by a ship that does not require a float free bracket or those that require an additional EPIRB. For example, to use in the wheelhouse or another protected area. A MB-60 is also used as a shipment bracket when sending replacement units. When the Tron 60S/GPS is mounted in the MB-60 bracket, it operates as a manual unit.



Figure 5 Image - MB-60 manual bracket

7 Installation

The Tron 60S/GPS must be installed and stored as described in this manual.



Do not install the EPIRB near strong magnetic fields, otherwise the EPIRB may be activated.

7.1 Brackets

Brackets should be mounted in a well protect area from environmental conditions such direct water spray, chemicals, oil, exhaust and vibrations.

7.1.1 Mounting the FB-60 float-free bracket

For best operation, the FB-60 should be mounted as high as possible within these requirements:

- The EPIRB should be mounted so that it can be released freely without getting caught in a railing or other superstructure.
- The EPIRB should be mounted so that it can be easily released by a person and brought to a survival craft. Do not mount on a radar mast or on any other surface that can only be reached by vertical ladder.

To mount the FB-60, do the following:

1. Using 5mm bolts mount the bracket according to the dimensions drawing.



The FB-60 can be mounted horizontally or vertically. A vertical position is recommended, however, do what is best for maintenance and operation.

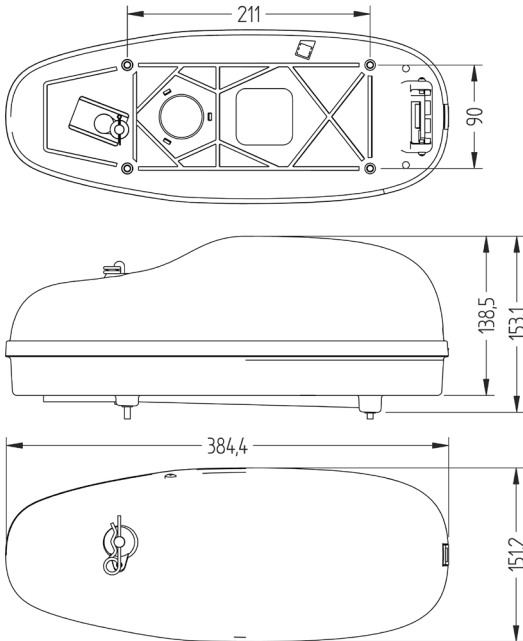

Figure 6 Illustration - FB-60 float free bracket dimensions

7.1.2 Mounting the MB-60 manual bracket

Ensure the bracket is mounted in an easily accessible location so it can be removed quickly in the case of an emergency.

To mount the MB-60, do the following:

1. Using 5mm bolts mount the bracket according to the dimensions drawing.



NOTE

The MB-60 can be mounted horizontally or vertically. A vertical position is recommended, however, do what is best for maintenance and operation.

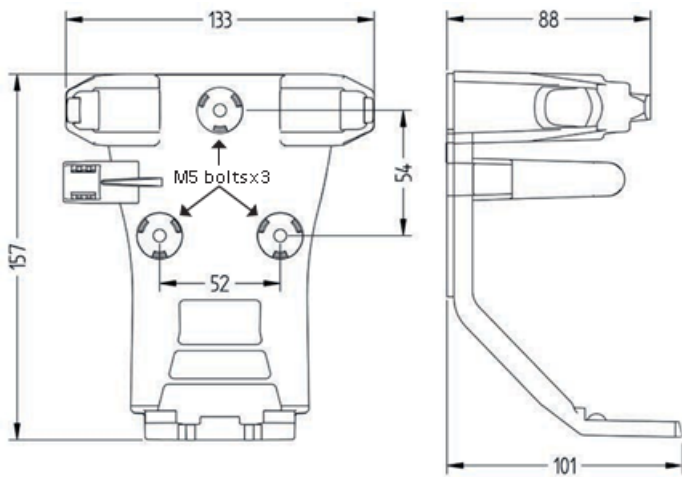

Figure 7 Illustration - MB-60 manual bracket dimensions

7.2 Replacing the battery

The Tron 60S/GPS battery must be changed at Jotron shore based maintenance (SBM) authorized workshop to be GMDSS compliant.

If your Tron 60S/GPS is not under any international or national regulations, battery can be change by authorized Jotron representatives/partners/dealers.

8 Operation instructions

Tron 60S/GPS is designed to be operated either manually or automatically. The EPIRB will automatically start to transmit when immersed into water. The Tron 60S/GPS has an internal safety switch which prevents inadvertent activation through moisture and water spray when located in the bracket. The EPIRB battery lasts for 48 hours from activation.

This EPIRB should only be used in an emergency. Should an EPIRB be used for any other reason, the user will be held responsible.



WARNING

Replace the battery after the EPIRB is operated for any purpose other than a test.

8.1 Manual operation



IMPORTANT

Keep the EPIRB in an open area and away from metal objects to ensure best performance (this includes ship construction).



CAUTION

Do not tie the lanyard to a ship during an emergency, this prevents the EPIRB from functioning if the ship sinks.

8.1.1 Out of bracket

To manually operate the Tron 60S/GPS out of the bracket, do the following:

1. Pull the safety ring holding the main switch.



2. Move the main switch to the ON position (left).



NOTE

The LED indicator located at the top of the antenna will start to flash. This indicates that the EPIRB is operational.

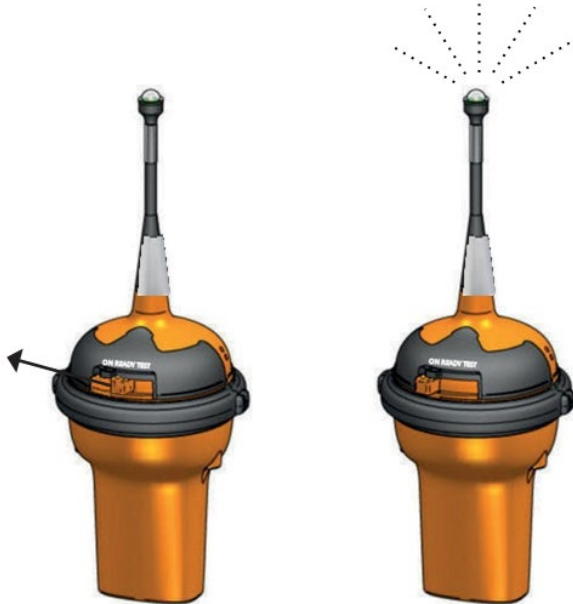

NOTE

To stop transmission, move the main switch to ready position.

8.1.2 Stored in the FB-60 float free bracket

To operate the Tron 60S/GPS stored in the FB-60 bracket, do the following:



NOTE

It is not recommended to operate a Tron 60S/GPS inside a life raft or under a cover or canopy.



WARNING

The EPIRB can drop out of the FB-60 bracket when releasing the top cover.

1. Remove the cotter pin from the bracket.



2. Remove the cover.



3. Remove the EPIRB from the bracket.



4. Pull the safety ring.



5. Push and move the main switch to the ON position.



NOTE

The LED indicator located at the top of the antenna will start to flash. This indicates that the EPIRB is transmitting.

6. Tie the EPIRB lanyard to yourself or the survival craft.



NOTE

To stop transmission, move the main switch to the ready position and secure the safety pin in place.

8.2 Automatic operation from the FB-60 float free bracket

During automatic release the following will occur:

1. When the bracket reaches a water depth of 2-4 meters or 6-13 feet the EPIRB will be automatically released.

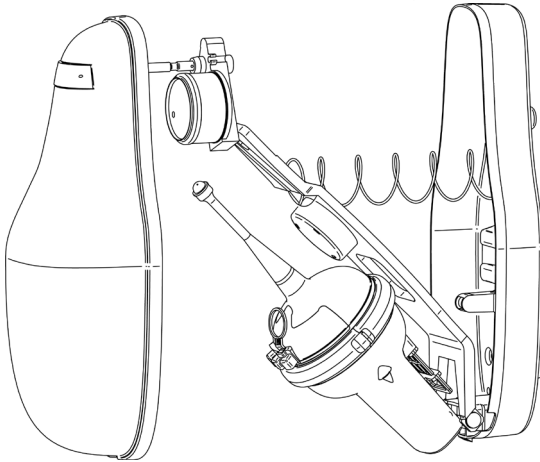

2. The EPIRB will then float to the surface and start transmitting.
3. Transmission is indicated by the flashing LED light and will continue until the EPIRB is lifted out of the water and dried off.



NOTE

The transmission can also be stopped by placing the EPIRB back into the FB-60 bracket.

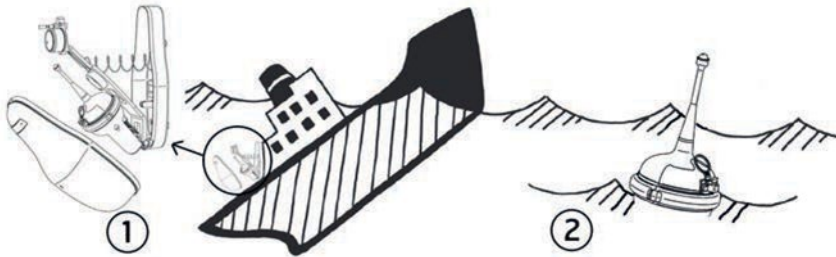

Figure 8 Illustration - automatic operation of a FB-60 float free bracket

8.3 Wrist strap

In an emergency the EPIRB can be carried using a Jotron wrist strap. Use the strap when it is necessary to have both arms free.

To use the wrist strap, do the following:

1. Pull the wrist strap out of the pocket.



2. Place your arm through the loop of the strap.



NOTE

It is not possible to put the wrist strap back into the pocket after use.

9 Maintenance

The Tron 60S/GPS requires the following maintenance:

Timing	Requirements
Every month	Both the EPIRB and the bracket should be inspected. The EPIRB should be removed from the bracket and tested. Perform inspection and testing following the steps outlined in this manual. Every 4 th month, perform an extended self-test (GPS – Tron 60GPS only) instead of the self-test.
Every year	Test in accordance with MSC. 1040, the annual performance test.
Every 2 years	In addition to the regular yearly inspection and testing, the HRU should be replaced (including the plastic bolt, FB-60 only). Mark the new expiry date on the label.
Every 4-5 years	The battery must be replaced and changed at a Jotron SBM authorized location (to be GMDSS compliant). Test in accordance

	with MSC. 1039 SBM. The SMB is decided by the flag state administration.
Every 10 years	Jotron recommends that the Tron 40VDR and FB-40 float free bracket are replaced at this time.

Table 3 Tron 60S/GPS maintenance requirements

9.1 Inspection

The lifetime of any equipment depends on how well you take care of it. Inspect both the Tron 60S/GPS and the bracket for defects.

To inspect, do the following:

1. Ensure the bracket cover is not blocked (this hinders the release functionality of the EPIRB).
2. Ensure the EPIRB and bracket are clean (no paint, oil and other chemicals).
3. Verify the lanyard is attached (on the EPIRB and not the vessel)
4. Verify the expiry date of EPIRB battery.

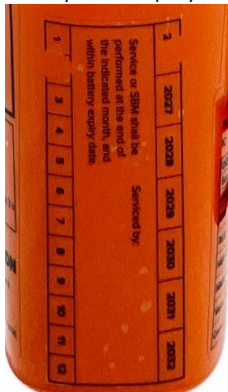

5. Verify the expiry date of HRU (month/year)



9.2 Testing

It is important to perform regular testing of equipment to ensure proper operation. This also ensures the EPIRB is in good working order and therefore ready for use in a potential emergency.

9.2.1 Self-test

The purpose of a self-test is to verify that the EPIRB functions as it should. During this test, a short test signal on 121,5MHz and 406,037MHz are sent to test the output of the transmitter and operation of the EPIRB. While transmitting the test signal, the battery voltage and status, output power and phase lock are tested. When testing the 406MHz transmitter a test message is transmitted, this test message is coded with a special synchronization code that will not be recognized as an actual alert by the Cospas-Sarsat satellites.

There are two types of tests:

1. Self-test
2. Extended self-test including GPS test



NOTE

Testing should be completed within the first 5 mins of an hour as the satellite EPIRB emits a 121,5 MHz signal during testing.

To perform a self-test, do the following:

1. Remove the EPIRB from the bracket.

2. Move the switch from the ready position to the test position and hold for 15 seconds.



IMPORTANT

Keep hands and/or other objects away from the antenna.

3. Release the switch.



NOTE

A single flash indicates a passed test. If this is not the result, refer to the error codes.



Figure 9 Illustration - self-test

9.2.1.1 Error codes (flashes)

If the self-test detects an error in the EPIRB module, one or more of the following will occur:

Number of Flashes:	Error codes
2	Low power on 406 MHz transmitter

3	Low battery voltage
4	Low power on 121.5 MHz transmitter
5	PLL on 406 MHz transmitter out of lock
6	PLL on 121.5 MHz transmitter out of lock
7	EPIRB module not programmed or programming not complete

Table 4 Tron 60S/GPS self-test error codes (flashes)

9.2.2 Extended self-test (GPS test) (only Tron 60GPS)

Upon completion of an extended self-test, a self-test will automatically occur. However, only when the extended test is successful. During an extended self-test, a GPS position is received. During the automatic self-test, the position is sent on 406.037 MHz. An EPIRB tester can be used to verify the GPS position during a self-test.



NOTE

Limit this test to a maximum of once a month as this testing reduces the lifetime of the EPIRB battery. The Tron 60GPS can only complete 60 GPS tests during the lifetime of 1 battery.

To perform an extended self-test including GPS, do the following:

1. Remove the EPIRB from the bracket.
2. Move switch to the test position twice within 3 seconds and release back to the ready position.



NOTE

The EPIRB will beep shortly every 3 second until the GPS position is acquired.



IMPORTANT

Keep hands and/or other objects away from the antenna.

3. A self-test will automatically take place after a successful GPS test and position transmission on 406.037 MHz. The GPS position may be received on an EPIRB tester for verification.



NOTE

2 beeps and a single flash indicates as passed test. If this is not the result refer to the error code tables for either flashes or beeps.

9.2.2.1 Error codes (beeps)

If the GPS test detects an error, one of the following will occur:

Number of Beeps:	Error codes
5	Did not acquire GPS positioning
10	Number of GPS test above limit (>60)

Table 5 Tron 60GPS GPS test error codes (beeps)

10 Replacing the hydrostatic release unit (HRU)

A replacement HRU must be purchased separately and is supplied in a kit. The HRU kit includes a special bolt and fittings.



WARNING

Only a Jotron approved hydrostatic release unit kit must be used, as it is type approved.



WARNING

The EPIRB can drop out of the FB-60 bracket when releasing the top cover.

To replace the release mechanism, do the following:

1. Remove the cotter pin from the bracket.



2. Remove the cover.



3. Remove the EPIRB from the bracket.



4. Press down and hold in place the spring-loaded catapult, then remove the HRU by sliding it out of the locking slot.



5. While holding the catapult down, slide the new HRU into the locking slot.



6. Place the EPIRB back in the bracket.
7. Close and secure the top cover using the cotter pin.



11 Test and maintenance records

Below is an overview of all test and control details.

Date	B/H/T*	Signature	Inspector name

*B=New battery, H=New HRU, T=Test

12 Battery safety information

Type:	Primary lithium metal
Lithium metal content:	Below 1gram lithium pr battery cell
Approximate weight:	116grams
Chemical system:	Lithium iron disulfide
Designated for recharge:	No

For information regarding the physical and chemical properties, the potential health and safety measures and the environmental effects of the battery used with this product, refer to the manufacturer's safety information documentation.

The safety information is available for download at jotron.com - product.
<http://jotron.com/product/tron-60s-epirb-manual-bracket/>.

12.1 Handling and storage

This product should be stored in a cool and well-ventilated area. Elevated temperatures can result in a reduction of battery life. Locations that handle large quantities of lithium batteries must ensure the batteries are isolated from combustibles. A short circuit for a few seconds will not seriously affect the battery. A prolonged short circuit will cause the battery to lose energy, generate significant heat and can cause the safety release vent to open. The contents of an open battery, including a vented battery, when exposed to water, may result in a fire and/or explosion. Crushed or damaged batteries may result in a fire. A battery that is disassembled or exposed to water, fire or high temperatures can explode or leak causing burns.

12.1.1 Transportation

The product described in this manual is subject to follow special packing instructions and/or transportation regulations. Information regarding these regulations (in accordance with ICAO/IATA, IMDG code and/or ADR/RID) is included in the product safety information (PSI) and/or in the test summary report (TSR) (in accordance with UN test 38.3.5) and available for download

at jotron.com - product. <http://jotron.com/product/tron-60s-epirb-manual-bracket/>.

13 Technical specifications

13.1 Product specification

Battery type:	Lithium iron metal
Battery capacity:	12V/2.9Ah
Housing material:	Glass reinforced polycarbonate
Unit dimensions (H/W/D):	340mm x 128mm x 128mm
Weight:	700grams
Compass safe distance:	0,85meters
Temperature operating:	-20°C to + 55°C (-4°F to +131°F)
Temperature storage:	-30°C to + 65°C (-22°F to +149°F)
Operating life:	Minimum 48 hours at -20°C
Lanyard length:	>5meters
Lanyard strength:	>25kg

13.2 COSPAS-SARSAT transmitter

Frequency:	406.037MHz \pm 2ppm
Output power:	5W
Protocols:	Location protocols (maritime, serialized)
Modulation:	Phase modulation 1.1rad \pm 0.1rad
Data encoding:	Bi Phase L
Stability:	Short term: $\leq 2 \times 10^{-9}$ Hz Medium term: $\leq 1 \times 10^{-9}$ Hz Residual noise: $\leq 3 \times 10^{-9}$ Hz Bit rate: 400bps Antenna: built-in omnidirectional

13.3 Navigation device (only Tron 60GPS)

Type:	56 channel GPS receiver
Antenna:	Chip type

13.4 Homing transmitter

Frequency:	121.500MHz
Output power:	Up to 100mW
Modulation:	A9, AM sweep tone between 300Hz and 1600Hz
	Sweep range: 700Hz
	Sweep rate: 2.5Hz
Stability:	10ppm over temperature range
Antenna:	Omnidirectional

13.5 Brackets

13.5.1 FB-60 Float-free bracket

Materials:	ASA (acrylonitrile styrene acrylate)
Dimensions (H/W/D):	385mm x 151mm x 148mm
Weight:	850grams
Release mechanism:	Jotron HRU
Temperature operating:	-30°C to + 65°C (-22°F to +149°F)
Temperature storage:	-30°C to + 65°C (-22°F to +149°F)

13.5.2 MB-60 Manual bracket

Materials:	PA6 + 30% fibre glass (Polyamide)
Dimensions (H/W/D):	156mm x 134mm x 98.5mm
Weight:	150grams
Temperature storage:	-30°C to + 65°C (-22°F to +149°F)

14 Optional accessories

For an overview of the available optional accessories for this product, refer to jotron.com.

15 Spare parts

For an overview of the available spare parts for this product, refer to jotron.com.

15.1 Counterfeit spare parts

Ensure that all spare parts being fitted to this product are only original spare parts manufactured or approved by Jotron.

Any use counterfeit parts will invalidate the product type-approval certificate.

16 Recycling and disposal

This product should not be disposed as normal waste and must be handled in accordance with the applicable federal, state and local waste disposal regulations in the country where the equipment is used.

17 Warranty

All Jotron products are warranted against factory defects in materials and/or workmanship during the warranty period.

Refer to the sales terms and conditions for specific warranty information regarding this product.

18 Service

All services such as testing, installation, programming, replacement, marking and battery exchange are provided by an authorized Jotron service agent.

Improper service or maintenance may destroy the functionality and/or performance of this product.

Jotron does not accept any responsibility for the dismantling or reassembling of any Jotron product that occurs externally from a Jotron authorized facility and/or is handled by someone other than an authorized, trained and certified person.

18.1 Service agents

Refer to jotron.com for an overview of Jotron partners and distributors.

<https://jotron.com/partners-and-distributors/>

19 Document revision log

Document revision log			
Rev	Date	Reason for Issue	Author
A	23.12.2010	New Manual (Total 32 pages)	TH
B	25.02.2011	Changed battery info (Ch 3.1.2)	TH
C	18.04.2011	Re-arranged pictures/drawings (pp. 13-29)	TH
D	19.09.2011	Info update (pp. 15, 22-25)	TH
E	10.11.2011	Info update on test (p. 24)	BR
F	20.01.2012	Update text and images (pp. 16-18, 30)	TH
G	08.02.2012	Update text (pp. 6, 16, 18, 20, 22 & 24)	ØE
H		Text and pictures	TH
I	22.05.2012	Updated text (pp. 6, 12, 16, 18, 26, 29-30)	FIT
J	26.06.2012	Battery info and EPIRB registration (pp. 6 & 16)	BR
K	16.10.2012	EPIRB registration (pp. 15-16)	ØE
L	29.11.2019	New layout, minor adjustments placard on (pp. 26 & 35)	ØB
M	16.12.2021	Updated content, revised text structure in a new documentation design and layout in accordance with new company profile.	WB

20 Emergency instructions

This is an overview of how to operate a Tron 60S/GPS during an emergency.



Figure 10 Emergency instructions overview



NORWAY / HEADQUARTERS

Jotron AS
Ringdalskogen 8
3270 Larvik, Norway
Tel: +47 33 13 97 00

SINGAPORE

Jotron Asia Pte. Ltd.
10 Ubi Crescent, Ubi Techpark
Lobby B, #05-11/12, Singapore 408564
Tel: +65 65 42 63 50

USA

Jotron USA, Inc
6300 Rothway Street, Suite C
Houston, TX 77040, USA
Tel: +1 713 268 1061

UK

Jotron UK Ltd.
Crosland Park, Cramlington
NE23 1LA, UK
Tel: +44 1670 712000

CHINA

Norway Jotron AS Beijing
Representative Office (ATC business)
No. 1204 room, building D
Tiejian plaza,
Chaoyang district Beijing 100012 China
Tel: +86 10 5619 6464

sales@jotron.com

jotron.com