

# PRODUCT MANUAL

## Classic 10 (V.3.0)

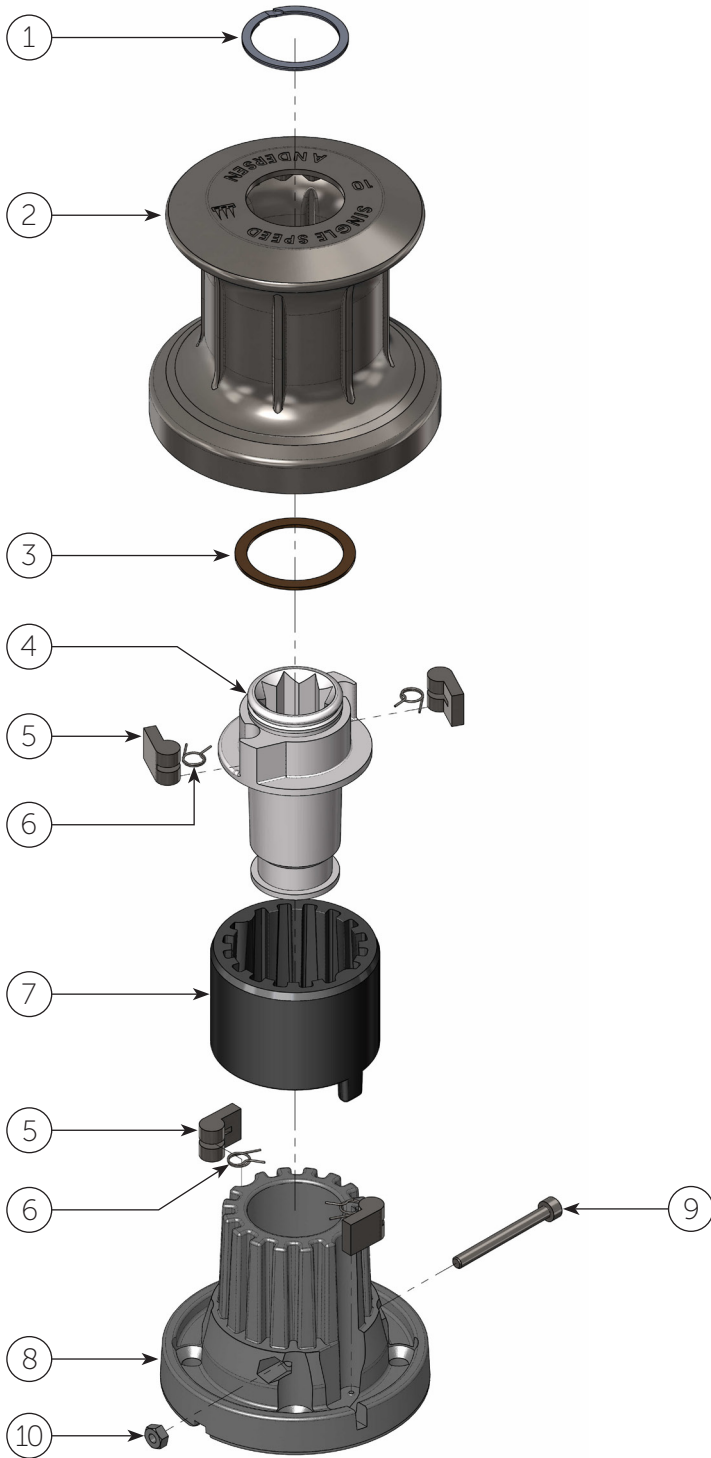

## EXPLODED VIEW



## I PARTS LIST

ITEM NO.	QTY.	DESCRIPTION	PART NO.
1	1	Circlip	712800
2	1	Drum	775210
3	1	Gliding washer	718400
4	1	Drive shaft	712702
5	4	Pawl	713200
6	4	Pawl spring	713300
7	1	Bearing	713103
8	1	Winch base	713102
9	1	Screw	DIN912-A4-M4x40
10	1	Nut	NU4
	1	Winch mounting dimension template	RD100505
	<b>1</b>	<b>Service kit No.4 (not included)</b>	<b>RA710004</b>

## I MOUNTING INSTRUCTIONS

Installing the winch is easy, if you follow these instructions. The numbers in ( ) refer to the item numbers in the parts list and exploded view diagram.

### Tools required for the installation:

- Small flat screwdriver.
- $\text{\O}6.5$  mm (1/4") drill.
- Pencil / marker.
- Cleaning cloth.
- Bedding compound.
- 4 x  $\text{\O}6$  mm (1/4") countersunk head screws and corresponding nuts (length to suit deck thickness).
- 4 x large washers or backing plate.
- Mounting dimension template (included).

1. Remove circlip (1), using a small flat screwdriver.
2. Remove drum (2).
3. Place the winch in the desired location on the boat and mark location of the bolt holes using the included template, or using winch base (8) as a template.  
**Note:** Do not drill through the winch base.
4. Remove the winch base.
5. Drill bolt holes  $\text{\O}6.5\text{mm}$  (1/4").  
Make sure that no dust comes into contact with the winch while drilling.
6. Clean the area.
7. Apply a light coat of bedding compound, ensuring that each bolt hole will be sealed.  
Keep area for drain groove in base clear.
8. Fasten the winch into place using 4 x  $\text{\O}6\text{mm}$  (1/4") countersunk head screws.  
Use large washers or a backing plate, on the underdeck side.
9. Assemble in reverse order.
10. Check that the winch is functioning correctly:
  - The drum should operate smoothly, when turning the drum clockwise by hand.
  - The drum must not turn when trying to turn the drum anti clockwise by hand.
  - While turning the winch handle clockwise the drum should turn.
  - While turning the winch handle anti clockwise the drum should not turn.

### Pawl spring mounting

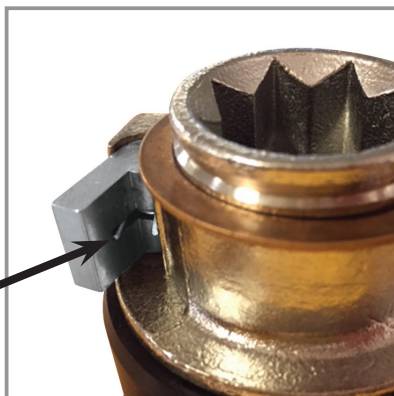
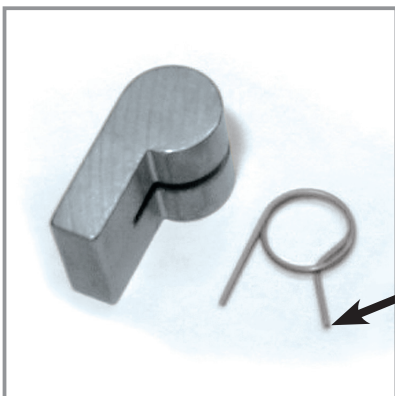

Note the orientation of the bent spring "arm"

## SERVICE INSTRUCTIONS

Maintenance interval 1-2 years, depending on operation conditions.

### Tools required for service:

- Small flat screwdriver.
- Large flat screwdriver.
- 3mm Allen key.
- Lock-in winch handle.
- White spirits/mineral spirits (no solvents).
- Hot soapy water.
- Small brush for cleaning.
- Small paint brush for applying winch grease.
- ANDERSEN winch grease.

### Use Service Kit No.4 - Product No. RA710004

1. Remove circlip (1), using small flat screwdriver.
2. Remove drum (2).
3. Remove the shaft retaining screw (9) and nut (10).
4. Remove the drive shaft (4), using a winch handle.
5. Remove the bearing (7).
6. Clean the drive shaft with white spirits/mineral spirits.
7. Clean all plastic parts in hot soapy water, and dry.
8. Check pawls & springs for wear and replace if necessary. In order to replace the upper pawls (5) or springs (6), the gliding washer (3) must be removed. The gliding washer is pressed on to the drive shaft (4). Use a large flat screwdriver to lever it off, taking care not to damage it.
9. Assemble in reverse order. During assembly, by the use of a small soft brush lightly grease internal drum teeth, drive shaft, bearing, pawls and springs. Pawls should only be lubricated with a very thin film of ANDERSEN WINCH GREASE. It is very important that pawls can move freely\*.
10. Check that the winch is functioning correctly:
  - The drum should operate smoothly, when turning the drum clockwise by hand.
  - The drum must not turn when trying to turn the drum anti clockwise by hand.
  - While turning the winch handle clockwise the drum should turn.
  - While turning the winch handle anti clockwise the drum should not turn.

**\*IMPORTANT:** When assembling the winch, check the functioning of each pawl by pushing the pawl against the spring. The pawls should move smoothly and automatically return to their normal position, where the pawls engage with the teeth. If the pawls do not function correctly, clean and lubricate the pawls and gears. Check the function of the pawls again to make sure that it works correctly. If the pawls do not work correctly replace the springs and recheck the functioning. Malfunctioning pawls may lead to unexpected release of the winch force resulting in fatal injuries to the user and others.

## GENERAL INFORMATION

Due to the best choice of materials and high precision in manufacturing, we recommend, for normal use, only to dismantle, clean and lubricate the winch once every second year. Under extensive use, such as racing, charter or blue water sailing, we recommend to lubricate the winch once every year.

We strongly recommend always to use ANDERSEN WINCH GREASE, when lubricating your winch. ANDERSEN WINCH GREASE is a high quality silicone/PTFE grease product.

Most other types of grease, including "marine grease" are not suitable for lubrication of winches. Non-suitable grease products can cause malfunction, which could result in fatal injuries for the user and others.

Pawl springs should be replaced every second year. Spare springs and other parts that may be required are included in the ANDERSEN Service Kit. Please refer to the service instruction for the Service Kit suitable for the specific winch.

When the winch handle is not in use but the winch is under load, we recommend, from a safety point of view, to remove the winch handle from the winch.

To ensure the best possible functioning of the winch, we recommend that the winch is placed in accordance with the line entry (shown below).

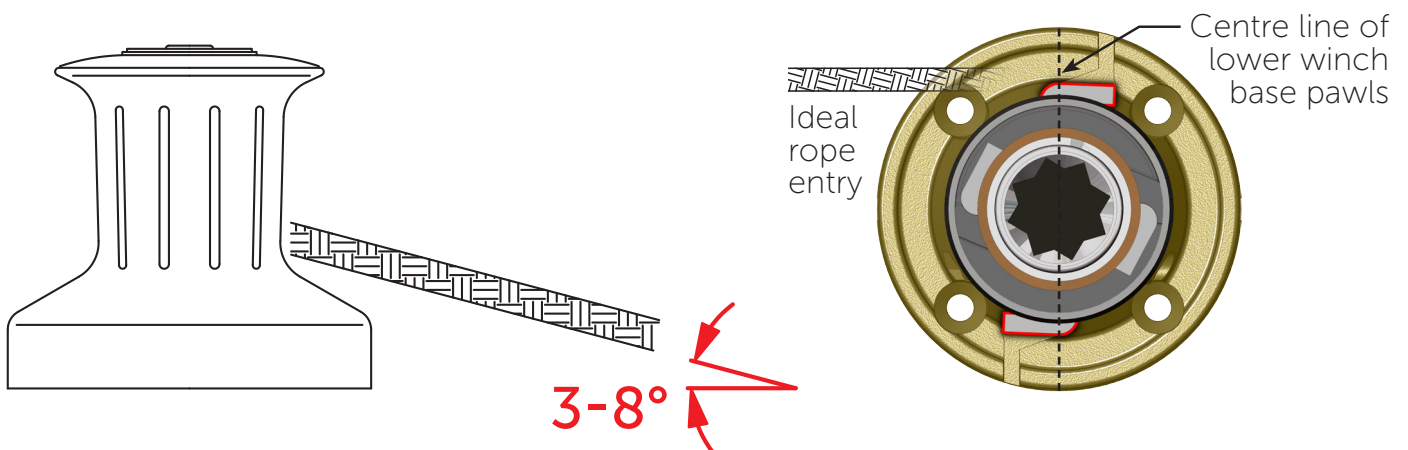

## I SAFETY NOTICES



### **Read All Safety Notices and Product Manuals**

Do not install or operate this winch before reading and fully understanding the contents of this Product Manual.



### **Stay Alert When Operating**

Andersen winches are very powerful and have the potential to cause significant damage and/or serious injury if used improperly or without due caution and vigilance.



### **Operators Must be Trained**

Help prevent significant damage and/or serious injury by ensuring any person operating a winch has a thorough understanding of its proper operation and is aware of the potential hazards involved. As a minimum, all winch operators must read and understand this Safety Notice Sheet and the Product Manual.

Particular attention is drawn to the following points:

- Children and others not qualified to operate a winch must be kept at a safe distance from the winch and any rigging or fittings that are under load.
- Long hair and/or loose clothing must be tied back to avoid being caught in the winch.



### **Avoid Accidental Operation**

Remove winch handles when not in use to help avoid unsupervised or unintentional operation. Failure to do so could result in significant damage and/or serious injury.



### **Lifting Operations**

Any lifting operations should be conducted by two persons in order to maintain constant visual contact with the object being lifted.

The rope must be secured properly by tying off, or leading to a suitable fitting such as a cleat or bollard.

**I Failure to observe these precautions could result in serious injury or death.**

**I DO NOT DISCARD**



# PRODUCT MANUAL

Classic 10 (V.3.0)

---

p8

## | WORLDWIDE DISTRIBUTION & SERVICE

| Visit [www.andersenwinches.com](http://www.andersenwinches.com)

## | WARRANTY

| Visit [www.ronstan.com/warranty](http://www.ronstan.com/warranty)

Manufactured by Ronstan Denmark ApS.  
Jægervænget 36 - 7100 Vejle - Denmark  
[office@ronstan.dk](mailto:office@ronstan.dk) - [www.andersenwinches.com](http://www.andersenwinches.com)

