

SEAFLO[®]

MANUAL TO ELECTRIC CONVERSION KITS

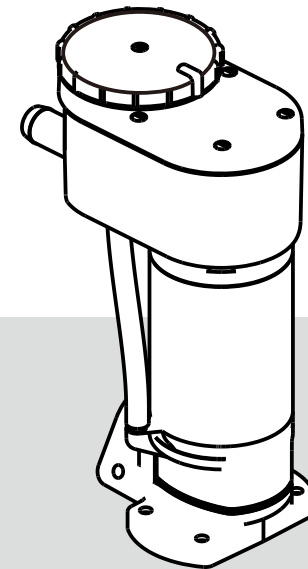

The Electric flush pump provides the convenience of an electric head without having to modify the platform or replace the head. The self-priming pump rinses the bowl while the waste pump macerates and evacuates the waste. Add the luxury of an electric head without the costly replacement and hassle by converting your existing toilet with an electric flush kit.

FEATURES

- Directly replaces manual pump assembly
- Easy to install
- Simple to operate
- Dual action control allows water level to be varied
- Suitable for use in above or below waterline installations.
- Built in macerator
- Self priming up to 0. 6m(2ft)
- Waste pump discharges over an anti syphon loop up to 1.8m (6ft) and out of a through hull fitting down to 0.9m(3ft) below the surface
- Typical power consumption is less than 1.0 amp hour(12 volt) or 0.5 amp hour (24 volt) per day

⚠ WARNING



Flood hazard. Close inlet and outlet seacocks prior to disassembling toilet. Failure to do so can result in flooding which can cause loss of property and life.

Your SEAFLO Electric Conversion is designed to be installed by the user; and no special skills or tools are needed.

Flush the existing toilet in the usual way, and ensure that all waste has left the discharge pipework, and that the bow is empty.

SHUT BOTH SEACOCKS (inlet and outlet)

Be ready to mop-up any water that may come out of the system. Keep all screws and hose clips, which will be re-used to fit the conversion.

Disconnect the 19mm (3/4) inlet hose and the pump to bowl link hose from the pump. Detach the discharge elbow, flange and joker valve assembly from the pump cylinder. Leave the discharge elbow connected to the discharge pipework and do not remove any anti syphon loop or 38mm(1 1/2") vented loop fitting. Remove the screws(key 11) that secure the pump to the discharge flange and base. Lift off the manual pump and gasket.

Should your power supply fail, you can change your toilet back to manual operation in a few minutes. Just keep the old pump to bowl link hose and bottom flap valve gasket aboard, together with the manual pump, and you will have all that you need to put your toilet back in commission.

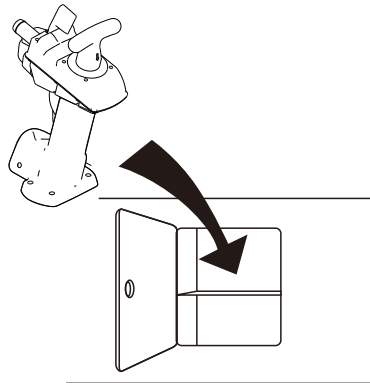

FITTING ELECTRIC CONVERSION SYSTEM

Check that the top of any anti-syphon loop in the discharge hose is not more than 1. 8m(6ft) above the base of the toilet. If it is, cut the discharge hose as necessary both to shorten it and to reposition any vented loop fitting so that the vent is at the top of the anti-syphon loop.

Ensure that there are no alternate rises and falls in the discharge pipework, except for the anti-syphon loop.

Ensure that the joker valve (key: 2) is in good condition, and that it is still in place in the discharge elbow.

Using the original screws, secure the Conversion to the discharge flange before you secure it to the base.



CAUTION: Failure to follow this procedure may result in leaks between the discharge elbow and the macerator housing (key 4~11).

In below waterline installations with the discharge connected to a through hull fitting the hose must be connected via a vented loop positioned a minimum of 200mm (8) above the waterline at all levels of heel or trim. The maximum height of the discharge hose must not exceed 1.8m(6ft).

Locate the new bottom gasket on its pegs on the base

Note that the new gasket does not have a flap valve.

Using the original screws, secure the SEAFLO Electric Conversion to the base.

Connect the inlet seacock to the flushing pump inlet hosedetail by the shortest possible route, WITHOUT any anti-syphon loop or vented loop fitting.

Cut and shorten the inlet hose as necessary. whether you are reusing an existing inlet hose, an altered inlet hose, or a replacement hose. Do not connect the pump inlet to a pressurized water system.

Ensure that there are no alternate rises and falls in the inlet pipework, which will create airlocks. The SEAFLO Pump guard supplied must be installed in the inlet hose, in a position where it can be easily inspected and cleaned.

If the level of the toilet base is above the waterline, the inlet hose MUST NOT be more than 3m (10ft) long. Failure to observe this caution may prevent the electric pump from priming, which may damage the Conversion.

Take the new white flushing hose provided and shorten it as necessary so that it will form a smooth curve, without kinking between the flushing pump outlet hose tail and the elbow at the

back of the bowl.

In some installations there may be re-circulation of waste via the inlet pump. In this instance fit a large length of hose between the pump and bowl, rising in a straight line to the same height as any loops in the discharge hose.

Secure the ends of all hose tails with stainless steel worm-drive hose-clips, ensuring that all inlet connections are airtight and that all outlet connections are watertight.

If it is difficult to fit the hoses on to the hose tails, soften the hose by dipping the end of it in hot water.



CAUTION: Do NOT apply flame to the hoses, Do NOT apply flame or any heat to the plastic hose tails on the toilet. Do NOT apply sealing compounds to any hose connections.

ELECTRICAL CONNECTIONS

The Conversion should be connected to the power source with an electrical circuit independent of all other accessories, Do not connect via existing distribution boards unless they are suitable for high amp draws.

The total length of wire should be kept to a minimum and the wire should be sized in accordance with the chart below. The wires, if not run through conduit should be supported every 450mm (18) with non metallic clips.



CAUTION: Inadequate wire size will result in voltage drop, and it will impair performance, and may damage the Conversion.

Protect your new wiring circuit by selecting the correct size of fuse holder or circuit breaker from the Electrical Specifications below, and install your choice in the positive power lead, within 170mm(7") of the battery.

Retain the fuseholder supplied with the Conversion to protect the unit.

Connect the Positive wire to the Red (positive) motor lead, and connect the Negative wire to the black (negative) motor lead



CAUTION: Correct motor Polarity (Red to Positive, Black to Negative) is essential. Incorrect Polarity will damage the Conversion.

Make all joints with appropriately rated terminal blocks, or crimp on terminals.

Fit fuse (supplied loose) into fuse holder.

ON COMPLETION OF INSTALLATION- SHUT BOTH SEACOCKS

RATED	NOMINAL FUSE		WIRE SIZE PER FEET OF RUN				
	VOLTAGE	AMPS	SIZE	0'-10'	10'-15'	15'-25'	25'-40'
12	24	25	12	10	8	6	4
24	13	15	16	14	12	10	10

* Length of run is the combined distance from the positive power source to the flush pump and back to ground. Wire sizes recommended will allow no more than a 5% drop in voltage.

OPERATING INSTRUCTIONS



Whenever the toilet is not in use both inlet and discharge seacocks must be closed - even if secondary valves are fitted. Failure to do so may result in flooding which can cause loss of property or life.

Ensure that ALL users understand how to operate the toilet system correctly and safely-including seacocks or secondary valves.

Take special care to instruct children, the elderly, and visitors.

The toilet is one of the most used pieces of equipment on your boat. Correct operation of the electric toilet is essential for the safety and comfort of your crew and your craft.

WARNING: NEVER RUN DRY! If you run the pumps without water for lubrication, you may damage the Conversion Therefore, before every usage, both seacocks (and secondary valves if fitted) MUST be open.

The Conversion has two electric pumps which require continuous water lubrication, On delivery, the flushing pump is specially lubricated to permit one period of ten seconds dry running.

In everyday use, the flushing pump and the base are designed to retain sufficient water to lubricate the pumps, But after long periods without use, water may evaporate from the base, if the water in the base does not reach the joint with the bowl, then

Open inlet and outlet seacocks (and secondary valves if fitted).

Half-fill the bowl with fresh water.

Turn the Control Knob (key 20) to the **Flush Discharge** position (←) and hold it there. The pump will start to discharge water from the bowl, and flushing water should appear from the rim of the

bowl within 10 seconds.

Release the Control Knob (key 20), which will return automatically to the Off position.



If flushing water does not appear within 10 seconds, release the Control Knob (Key 17). Do NOT run the pumps again until you have manually primed the flushing pump.

NORMAL USE



OPEN INLET AND OUTLET SEACOCKS (and secondary valves if fitted).

Before use, ensure that there is some water in the bowl! to prevent the toilet paper becoming compacted at the bottom of the bowl. If the bowl is empty, turn the Control Knob (key 20) to the **Flush & Discharge** position (←) so that some flushing water is pumped in.

During use, you may turn the Control Knob (key 20) to the **Discharge Only** position (→) so that some waste is pumped out as necessary to keep the contents of the bowl low enough for comfort.

Use good quality hard or soft house hold toilet paper, but do not use more than is necessary.

After use, turn the Control Knob(key 20) to the **Discharge Only** position (→) and hold until the bowl is

almost empty. Then turn the Control Knob to the **Flush & Discharge** position () and hold until all waste in the discharge pipework has either left the boat, or reached the holding tank (allow 3 seconds per meter (yard) length of pipework). Lastly turn the Control Knob back to the **Discharge Only** position() and hold it there until the bowl is empty.

Always leave the bowl empty to minimise odour and spillage.

SHUT INLET AND OUTLET SEACOCKS



CAUTION: Do not put anything in the toilet unless you have eaten it first, except the toilet paper. Do NOT put in: Sanitary Towels, Wet Strength Tissues, Cotton Wool, Cigarettes, Matches, Chewing Gum or any solid objects, Petrol, Diesel, Oil, Solvents of any kind or water more than hand hot.

CLEANING

- Regular flushing with clean sea water is one of the most effective methods of keeping the toilet clean and sweet smelling.
- To clean the bowl, use any liquid or cream ceramic cleaner.
- To clean the rest of the toilet, including the seat and lid, use a non abrasive liquid cleaner, Polish with a dry cloth only.



CAUTION: Do not use abrasive pads on any part of the toilet and do not use abrasive cleaners except for the bowl.

- To disinfect the toilet, use a liquid disinfectant diluted in accordance with the manufacturers instructions. You may apply it to all parts of the toilet using a sponge or soft brush as necessary.



CAUTION: Do not use thick liquid toilet cleaners or neat bleach, They may damage the valves, gaskets and seals.

- After applying any cleaning or disinfectant agent, always flush well.



CAUTION: Do not allow these agents to stand in the system.

WINTERISATION

CLOSE BOTH SEACOCKS

Drain the complete system both as a protection against frost damage and to discourage the growth in the pipework of anaerobic bacteria that cause unpleasant smells.



CAUTION: The use of anti-freeze is NOT RECOMMENDED,as it is difficult to ensure that it penetrates the complete toilet system. If, for any reason, anti-freeze is used, it MUST be glycol based.

Open any secondary valves.

Remove the base drain plug.

Disconnect the discharge flange from the Conversion, (avoiding the need to remove the outlet hose from the discharge elbow).

Loosen hose clips and disconnect the other hoses from the flushing pump inlet hose tail, the seacocks and secondary valves. If fitted, Do NOT remove the bleed hose (key 1).

Turn the Control Knob(key 20)to the **Flush & Discharge** position () for 3-5 seconds.



CAUTION: If you run the pumps for longer than 5 seconds. You may damage the Conversion.

Ensure that all water is drained from the toilet system.

Reconnect the discharge flange to the Conversion.

Reconnect all hose ends and secure them with their hose clips.

Replace the base drain plug securely.

Disconnect the electrical supply.

Fasten down the seat and lid to prevent use, and attach a warning notice.

SERVICING

WARINGS

If the pump is operated accidentally when any part of your fingers are in the macerator chamber the chopper may cause injury.

If the toilet is connected to ANY through-hull fittings, and if the toilet or the pipework develops a minor leak, it can suddenly become the craft to sink, which may result in LOSS of Life.

If you leave the toilet dis-assembled, and if the seacocks are opened when the craft is afloat, water will flood in and may cause the craft to sink, which may result in Loss of Life.



CAUTION: For the safety of your crew and your craft, use only genuine SEAFLO replacement parts.

CLOSE BOTH INLET AND OUTLET SEACOCKS

- REMOVE FUSE, and disconnect the electrical supply.
- Remove the Conversion as follows:
- Loosen hose clips, disconnect the inlet pipework and the flushing hose from the flush pump housing (key 13).
- Remove the 2 screws that secure the discharge flange to the macerator housing.
- Remove the 4 screws that secure the macerator housing to the base.
- Lift off the Conversion, and pick up the base gasket (key 6) and the joker valve(key 3).

DO NOT remove the bowl from the base.

The flushing pump and the waste pump may be serviced independently if necessary, but are most easily serviced together.

Dis-assemble the flushing pump assembly as follows:

- Remove the short screw that secures the Control Knob (key 20), and gently lever off the knob.
- Remove the 7 long screws that secure the flush pump cover assembly(key 16.17), and lift it off together with the cork gasket (key 16)
- Lift out the brass wearplate and the flushing pump impeller(key 6).
- Lift out the switch and switch spring and gently disconnect the red positive wires.
- Push the control valve assembly (key 14) up and out, using a blunt instrument inserted up the inlet hose tail.
- Pull the bleed hose(key 1) off the flush pump body(key 13).
- Remove the 2 screws that secure the flush pump body (key 13) to the motor (key 12) and lift off the body.
Push out the seal (key 10)using a blunt instrument, taking care NOT to damage the seal seat area in the body.

Re-assemble the flushing pump assembly as follows

- Press the new U-cup seal (key 10(b)) into the flush pump body (key 13) with the open side of the seal facing into the impeller chamber.
Lubricate the motor shaft. the sides and the bottom of the flushing pump impeller chamber with petroleum jelly. Pushing the flush pump body (key 13) onto the motor shaft, using its locating pegs to align it on to the motor(key 12), and finally secure it with the 2 screws.
- Push the free end of the bleed hose onto its hose tail on the underside of the flush pump body(key 13).
Fit the new impeller(key 8)by rotating it CLOCKWISE to engage the flat on the motor shaft, and continue to rotate it as you push it to the bottom of the impeller chamber.

- Push the control valve assembly into the chamber above the inlet hose tail.
- Use the locating peg on the switch(key 14.15.16)to ensure that it is the right way up before re-connecting the red positive wires to its terminals, and then locate the switch onto its spring(key 14.15.16).
- Locate the brass wearplate inside the lip of the flushing pump impeller chamber, and locate the new cork gasket (key 16)on its pegs on the flush pump housing.
- Secure the flush pump cover assembly(key 16.17)with the 7 long screws, and refit the Control Knob(key 20)with the short screw.

Refit the Conversion as follows:

- Place the joker valve(key 3) into the discharge elbow.
- Using the original screws, secure the Conversion to discharge elbow flange before the unit is secured to the base.



CAUTION: Failure to follow this procedure may result in leaks between the discharge elbow and the macerator housing(key 15).

- Locate the bottom gasket on its pegs on the bases.
- Using the original screws, secure the Conversion to the base. Examine all hoses throughout their length for chafe, kinks and splits under hose clips, check all hose clips for corrosion and replace worn or damaged parts.
- Reconnect all hose ends and secure them with their hose clips.

If it is difficult to refit the hoses onto the hose tails, soften the hose by dipping the end of it in hot water.



CAUTION: Do NOT apply flame to the hoses. Do NOT apply flame or heat to the plastic hose tails on the toilet. Do NOT apply sealing compounds to any hose connections.

Ensure that the base drain plug is securely in place.

Inspect pumpguard in inlet hose, remove bow and clean out any debris surrounding the filter screen or in the inlet port. Replace bow securely.

REPLACE FUSE and reconnect the electrical supply.

OPEN SEACOCKS AND CHECK FOR CORRECT OPERATION.

TROUBLE SHOOTING

FAILURE TO PRIME CAN BE CAUSED BY

1. Inlet seacock or secondary valve not fully open-open fully.
2. Inlet seacock or valve blocked - unblock.
3. Inlet connections not airtight- tighten hose clamps.

4. Vented loop fitting fitted on inlet side of pump-remove.
5. Anti syphon loop installed on inlet side of the pump-remove.
6. Alternate rise and falls on inlet pipe run- make pipe runs as short and straight as possible.
7. Low voltage- check battery state and cable size.
8. Damaged impeller- replace.

After correcting the installation you must manually prime the flushing pump before restarting.

Disconnect the inlet hose from the flushing pump.

Shut inlet seacock, disconnect the inlet hose from the flush pump.

Disconnect the outlet hose from the back of the bowl or vented loop fitting and fill with clean water. Hold it upwards and turn the control knob(key 20) to the **Flush and Discharge** position () for 10 seconds. Air will escape from the inlet hose tail and the water will flood the priming chamber.

Reconnect the inlet hose. Reconnect the hose to the back of the bowl or vented loop,

Open the seacock.

The pump should now be ready to run.

FAILURE TO DISCHARGE CAN BE CAUSED BY

1. Damaged impeller-replace.
2. Blockage in discharge hose - unblock.
3. Blockage in bleed tube -unblock.
4. Low voltage check battery state and cable size.

DIMENSIONAL DRAWING

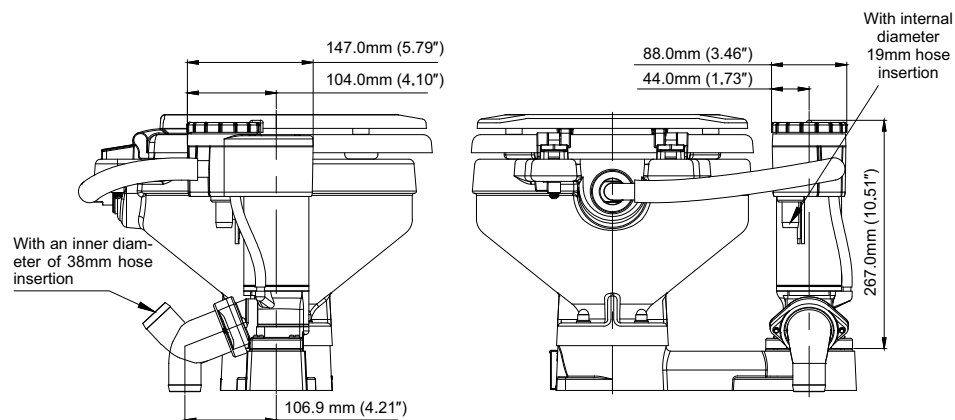

EXPLODED VIEW

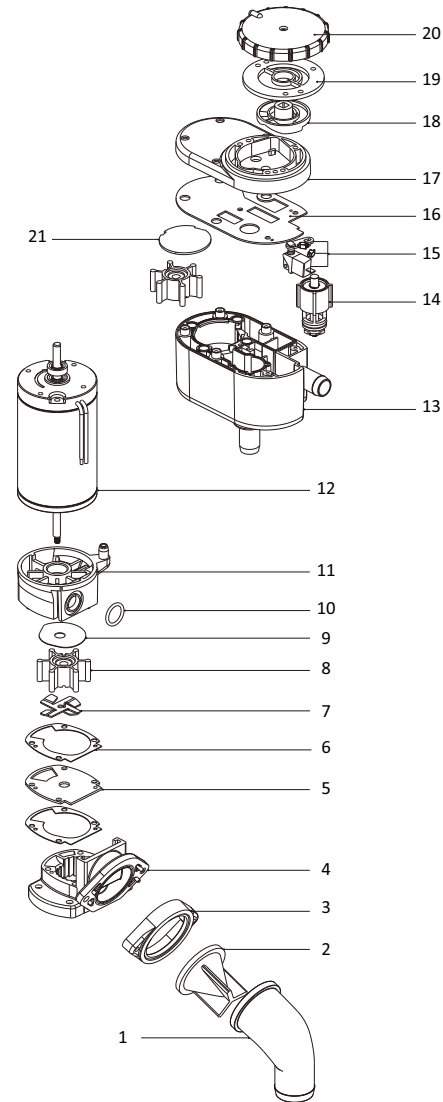

1	Sewage elbow
2	Drain valve
3	Flange
4	Pump head
5	Shell compression
6	Shell seal
7	Blade
8	Impeller
9	Convex piece
10	Seal ring
11	shell
12	Motor assembly
13	Middle cover
14	Check valve body assembly
15	Micro Switch
16	Middle cover gasket
17	Upper cover
18	Rotating the lower cover
19	Fixed cover
20	Rotating the cover
21	Impeller cover