



Installation Guide

For DC External Electric Thruster Models
SX35, SX50



SLEIPNER MOTOR AS

P.O. Box 519

N-1612 Fredrikstad

Norway

www.sleipnergroun.com

DOCUMENT ID: 5630

REVISION: 24

DATE: 2022

LANGUAGE: EN

MI

Contents

Installation Manual	
Responsibility of the Installer.....	3
General Installation Considerations and Precautions Guidelines	3
Product Measurements	4 - 5
Product Specifications	6
Galvanic Isolation	6
Positioning the Stern SX Thruster	7
Guide for Stern Thruster Cowls or Grids	8
Tunnel Installation	9
SX Spacer	10
Motor Installation	11 - 12
Propeller Installation	13
Grids or Cowls assembly.....	14
Electrical Installation.....	15
Control Box Installation.....	16 - 17
Visual Wiring Diagram	18
Control Panel Installation	19
Pre-delivery Checklist	20
Service and Support.....	21
Product Spare Parts and Additional Resources.....	21
Warranty Statement.....	21

Products

SM908124 | SX35/140-12V-50MM - SX35/140 -12V -50mm w/Controller
SM908123 | SX35/140-12V-150MM - SX35/140 - 12V -150mmw/Controller
SM908125 | SX35/140-12V-OEM02 - SX35/140 - 12V -OEM02 w/Controller
SM908126 | SX50/140-12V-150MM - SX50/140 - 12V-150mm w/Controller
SM908127 | SX50/140-12V-50MM - SX50/140 - 12V -50mm w/Controller



Sleipner Motor AS
P.O. Box 519, Arne Svendsensgt. 6-8
N-1612 Fredrikstad, Norway

MC_0020

Failure to follow the considerations and precautions can cause serious injury, damage and will render all warranties given by Sleipner Motor as VOID.

MC_0411

Responsibility of the Installer

MC_0038

The installer must read this document to ensure necessary familiarity with the product before installation.

Instructions in this document cannot be guaranteed to comply with all international and national regulations. It is the responsibility of the installer to follow all applicable international and national regulations when installing Sleipner products.

The recommendations given in this document are guidelines ONLY, and Sleipner strongly recommends that advice is obtained from a person familiar with the particular vessel and applicable regulations.

This document contains general installation instructions intended to support experienced installers. If you are not skilled in this type of work, please contact professional installers for assistance.

If required by local regulation, electrical work must be done by a licensed professional.

Appropriate health and safety procedures must be followed during installation.

Faulty installation of Sleipner products will render all warranties given by Sleipner Motor AS.

General Installation Considerations and Precautions Guidelines

MC_0440

For thruster systems

MC_0425

- Do not install the thruster in a position where you need to cut a stiffener/ stringer/ support that may jeopardise the hull integrity without checking with the boat builder this can be done safely.
- We advise painting the gear house and propellers with anti-fouling. **(NB: Do not paint the anodes, sealing, rubber fittings or propeller shafts)**
- There is only room for a thin coat of primer and two layers of anti-fouling between the tunnel and the props.
- Never run the thruster out of water.

For SX/P35 and SX/P50 thruster systems

MC_0427

- Ensure that the external thruster assembly does not disturb the water flow under the hull. At higher speeds, if the thruster is installed too low it can cause damage to the thruster and/ or add additional drag and unwanted water splashing.
- The minimum tunnel depth from the water surface is 140mm (5,51') to the centre of tunnel diameter. Place the Thruster as deep as possible for better performance and reduced noise.
- When installing the thruster ensure it does not foul existing equipment inside the boat like motor bedding etc.
- If able ensure that stern-drives/ trim-tabs do not interfere with the water flow from the thruster as this can reduce the thrust effectiveness considerably. We recommend the use of our Sleipner cowls to enhance the performance and allow installation in shallow draft boats. Sleipner cowls will also minimise the effect if stern-drives/ trim-tabs obstruct the thruster.
- Ensure there is enough space both inside and outside the transom of the boat and the thruster does not get in conflict with existing equipment inside the boat like steering links etc. **(NB: It is possible to mount the tunnel offset from the boat's centre line if necessary.)**
- Heat protection cut off is calculated from the thruster motor. To avoid cable overheating do not install place the volt cables from the thruster to the control box near any heat sources. **(NB: excluding SXP thrusters)**
- Do not lift it by internal cable connections, main terminals.
- The thruster power supply circuit must include the recommended sized fuse and a battery isolation switch.
- The electro motor, components and cables must be mounted so they remain dry at all times.
- Do not use abrasive tools damaging the existing Epoxy coating when preparing for antifouling paint.

NEVER Disassemble any part of the Ignition Protected assembly. Tampering with the Ignition Protected assembly will cause it to lose this safety feature. If there is a problem with your Ignition Protected motor, please contact your dealer.

MC_0007

Measurement code	Measurement description	mm	inch
H	Motor Height	374	14.72
W	Width	183	7.20
L	Length	171	6.7
(a)	Standard tube length	171	6.7
(b)	Extended tube length for thicker hulls	276	10.9
(c)	Main tube diameter	50	2
(d)	Support bolts diameter	18	0.7
(e)	Height of support bolts from tube	35.8	1.4
(f)	Distance of support bolts from tube	65	2.6
(g)	Distance of support bolts	130	5.1

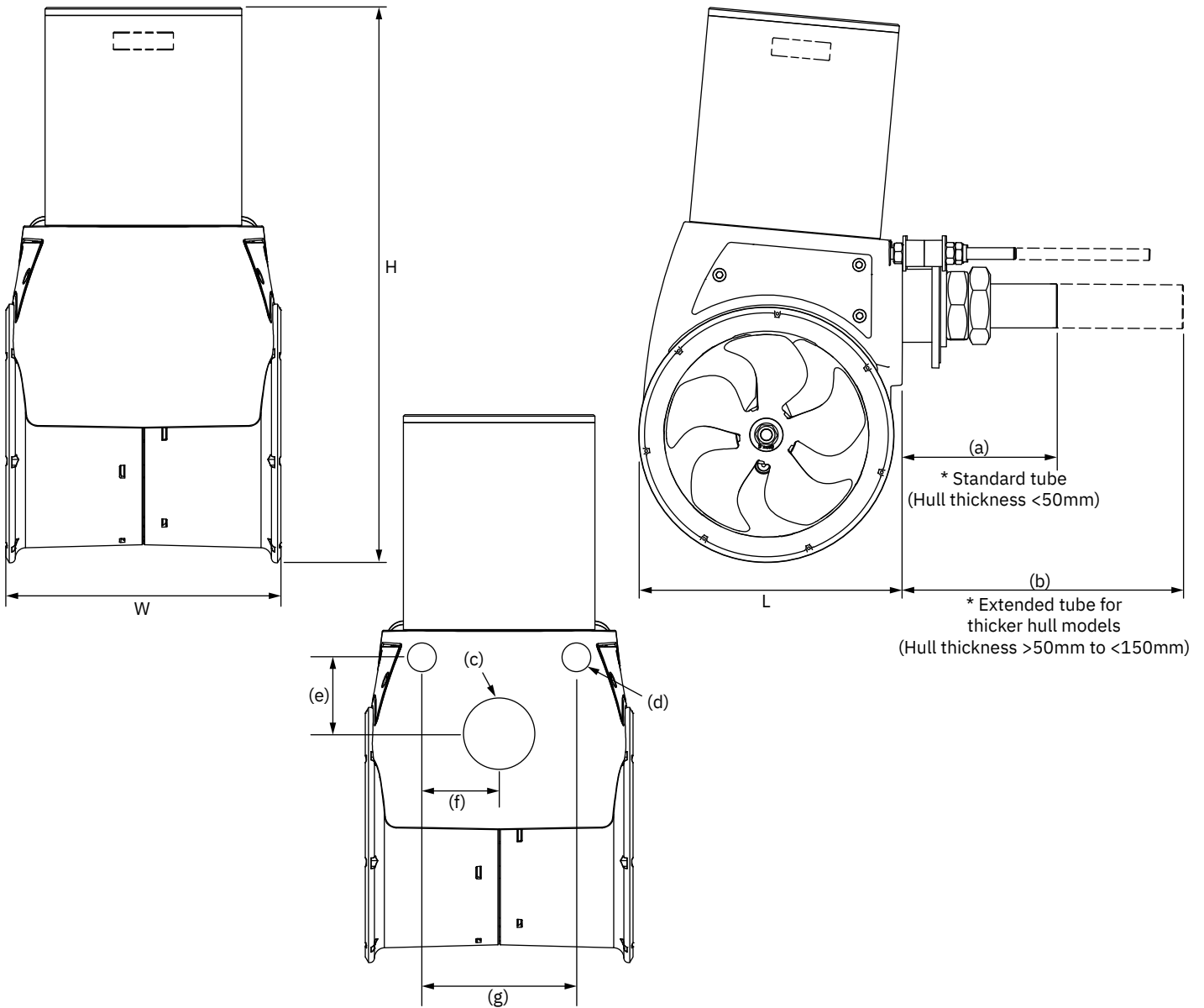

Product Measurements

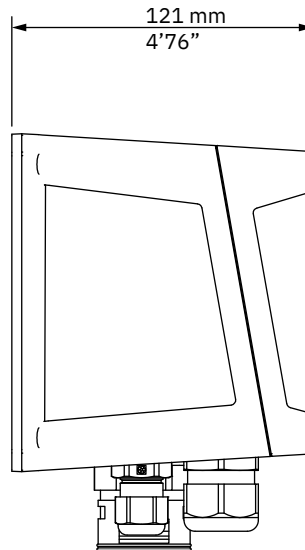
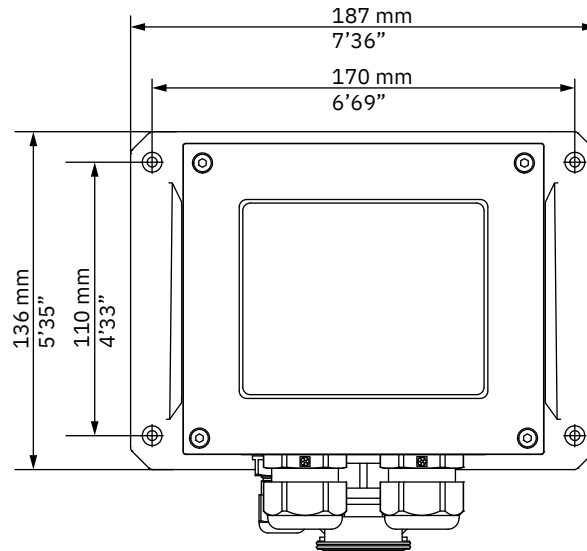

MG_0132

SX/P Thruster

Description	SX35 SXP35	SX50 SXP50
Nominal Voltage	12V	12V
Thrust 12V	43 kg / 94 lbs	62 kg / 136 lbs
Thrust 10.5V	35 kg / 77 lbs	50 kg / 110 lbs
Maximum Operation Time	S2 motor at 2 - 3 min. duty cycle at 20°C (ambient temperature)	S2 motor at 2 - 3 min. duty cycle at 20°C (ambient temperature)
Power	1.8kw / 2hp	2.8kw / 3.75hp
Weight	15.3 kg / 33.73 lbs	15.3 kg / 33.73 lbs

SX/P Control Box

Product	SX35 SXP35	SX50 SXP50
Nominal voltage	12V	12V
Max current	250A	380A
Motor duty cycle	Short time duty (S2)	Short time duty (S2)
Max ambient temp	50°C	50°C
Min ambient temp	-25°C	-25°C
Cross section power cables	35 - 70mm ²	2.8kw * 3.75hp

Galvanic Isolation

The SX models are produced with a seawater resistant aluminium frame. Without galvanic isolation from other electrical sources the SX seawater resistant aluminium frame will act as an anode on the vessel. This will add considerable corrosion to the SX thruster frame.

WARNING

IF installing on any metal surface with contact to the SX seawater resistant aluminium frame (vessel hull, supports or frames) the SX thruster must include a galvanic isolation solution.

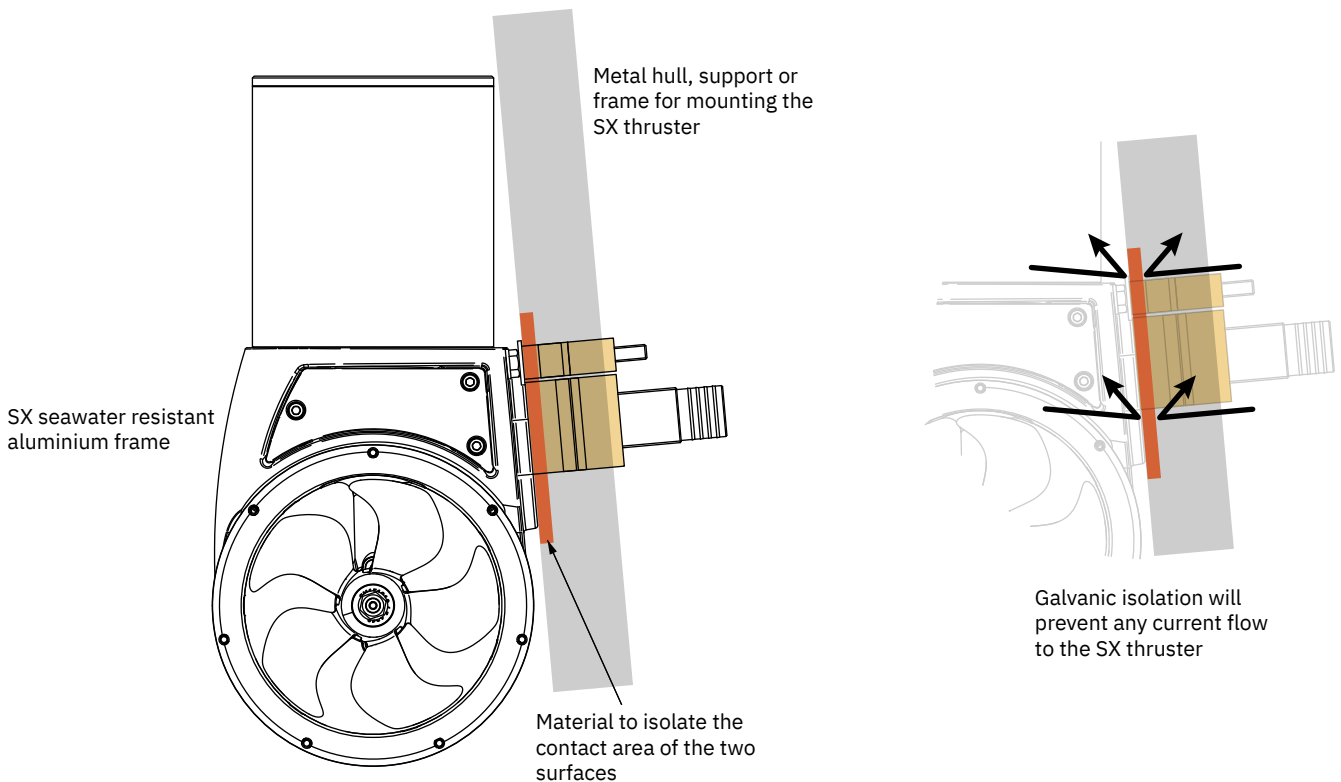

For best performance, the thruster must be installed as deep on the stern as possible but not disturb the natural water flow dynamic of the hull as the vessel travels.

The thruster should be installed as deep under the waterline as possible for two reasons:

1. So it does not suck air from the surface which will reduce performance and increase noise levels.
2. To receive maximum efficiency in turning force.

The thruster must be installed to ensure the propulsion water flow must not be obstructed by other objects. Objects that obstruct the water flow from the thruster will greatly reduce the thrust output.

Position

The thruster can be installed in multiple locations on the boat transom. Installing the thruster slightly off centre will not affect the overall effectiveness of the thruster. Installing the thruster off centre may be required to avoid any obstructions externally or internally on the vessel.

Ensure that the external stern thruster assembly does not disturb the water flow under the hull. At higher speeds, if the thruster is installed too low can cause damage to the thruster, additional drag and unwanted water splashing.

Alignment

The thruster can be installed at a slight angle if required for the water flow to avoid obstructions. These obstructions can include propellers systems, trim tabs or the hull. The average force the thruster propels water is 5-7 meters per sec, therefore angled installations must be as deep as possible under the water to minimise spray breaking beyond the water surface. **(NB: install the thruster at an angle only if no other suitable location can be found.)**

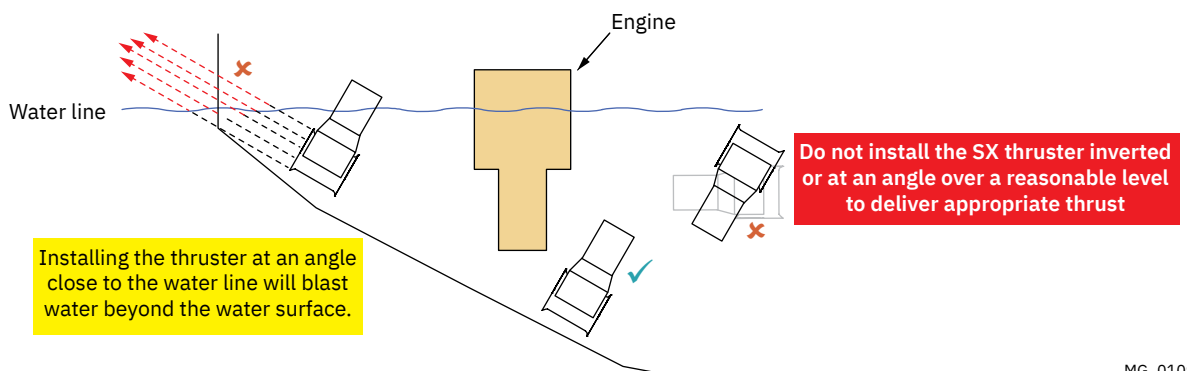
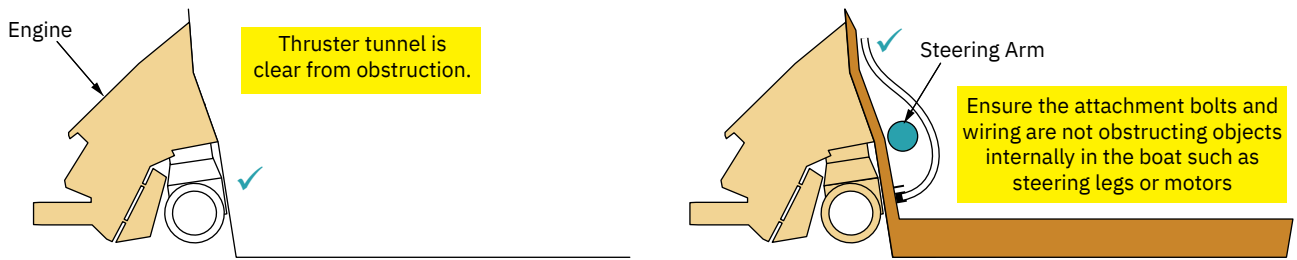
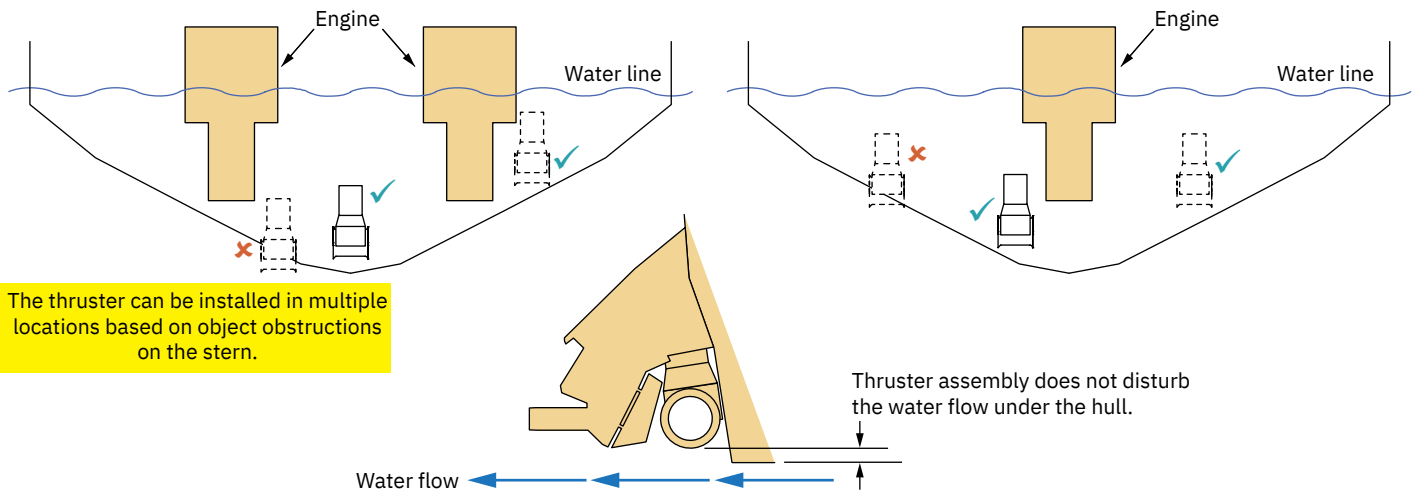

Installing a stern thruster cowl for stern thrusters that will allow installations in boats with shallow drafts or due to other obstructions on the stern. These can include obstacles such as trim tabs, jets or surface drive propeller systems where shallow installation of a stern thruster is the only option.

Cowls:

Designed to aid in water redirection and reduce air entering the tunnel in shallow installations.

Grid's:

Designed to protect the thruster from objects while in use.

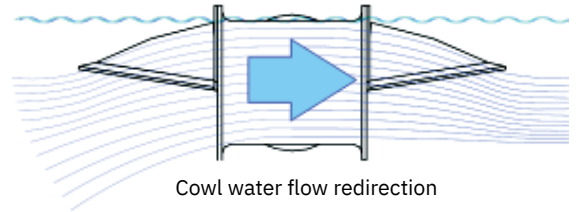
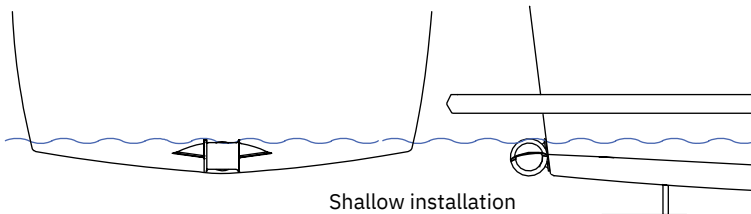

Composite material with smooth inner walls for optimal water flow and strength

Radius corners prevent turbulence

An angled edge further preventing air attraction into the tunnel

Easy installation for easy bolt-on fitting

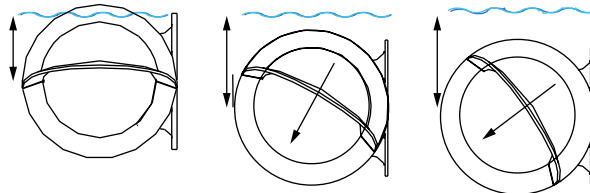
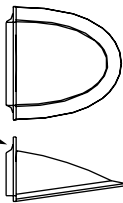
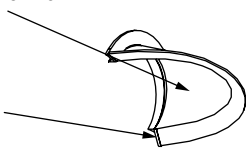

cowls to change the water flow direction to avoid obstructions on the stern

cowls help prevent air from the water surface entering the tunnel in shallow installations

IMPORTANT
Angled cowls out of horizontal, must be installed deeper to avoid air entry in the thruster tunnel

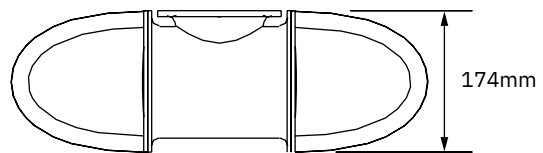
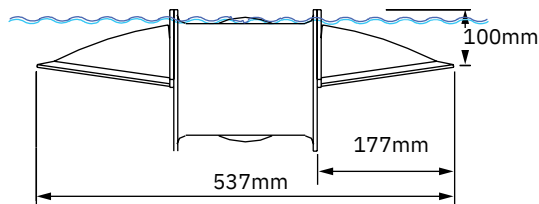

1. Connect both ends of the tunnel to the thruster motor. All hooks must be completely interlocked making the inside of the tunnel smooth. **(NB: Ensure tunnel moulding around the gear leg and tunnel top align.)**

IMPORTANT

Ensure all snap-lock positions are correctly connected into place.

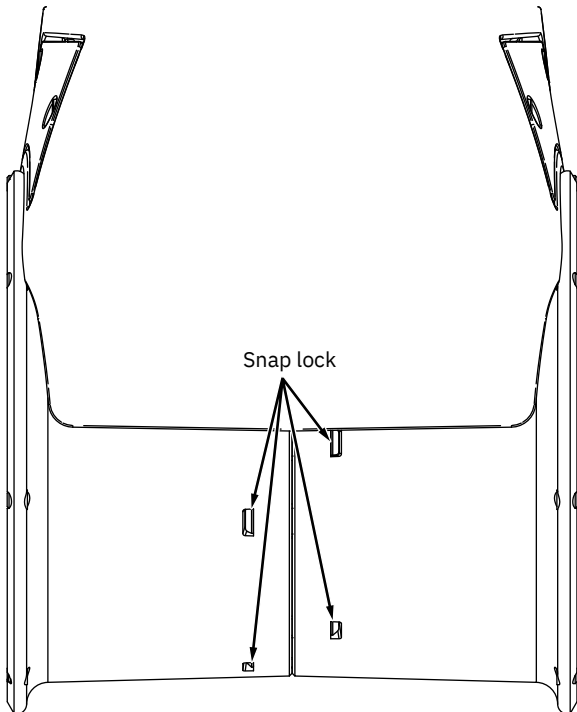

1

Check snap lock positions around the tunnel.

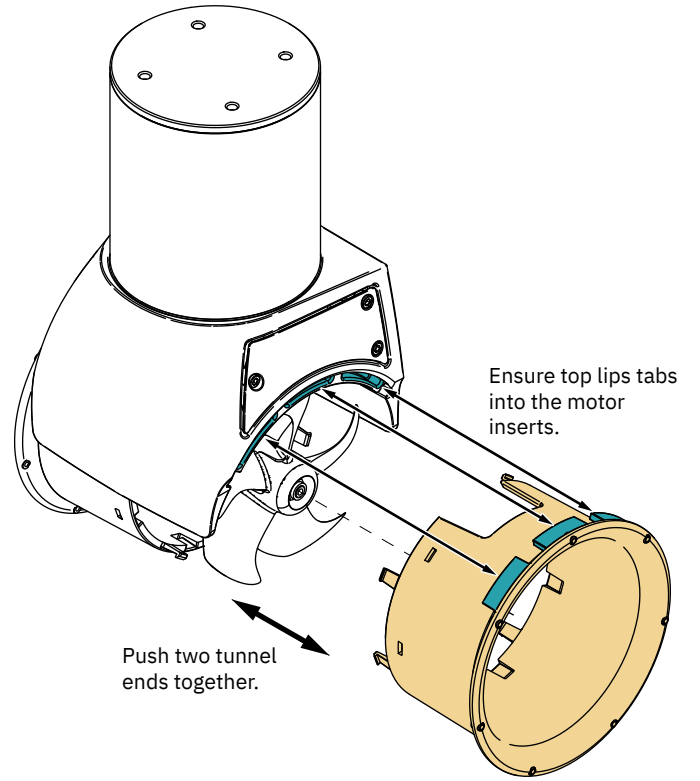

MG_0112

Follow the installation of the SX thruster in the **Motor Installation** to step 3. see next page

1. Define the location to install the thruster. **(NB: Ensure the thruster does not protrude past the transom profile on any side and there is no obstruction to the thrusters water flow. Also, check internally the thruster will not obstruct any objects.)**
2. Mark the locations of the three drill holes using the defined measurements in this manual or from a template. **(NB: Maximum hull thickness is 50mm including optional spacer or 150mm for extended hull thickness models.)**
3. Drill main hole, then two support bolt holes. Clean the area from dust for installation of the thruster. **(NB: Hull holes must be drilled first before attaching the spacer as the top support holes are larger than the spacers.)**

-
4. Drill out the two support bolt holes in the spacer.
 5. Apply MS Polymer sealant or equal to the back surface face of the spacer.
 6. Place the spacer to the hull.

Continue the installation of the SX thruster from step 4 in the **Motor Installation**.

IMPORTANT

If using the 50mm spacer ensure you have the extended tube SX model.

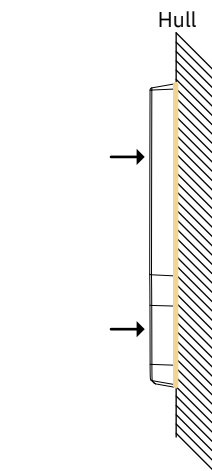
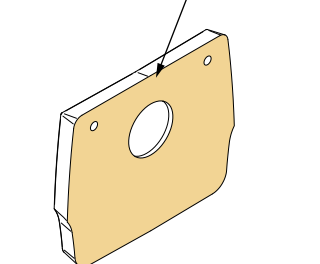
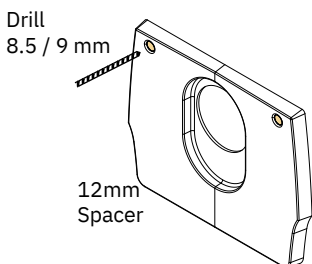
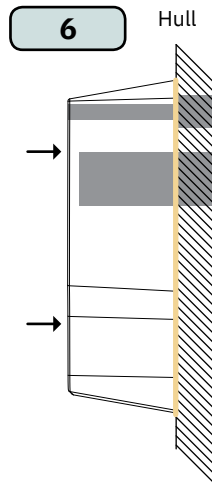
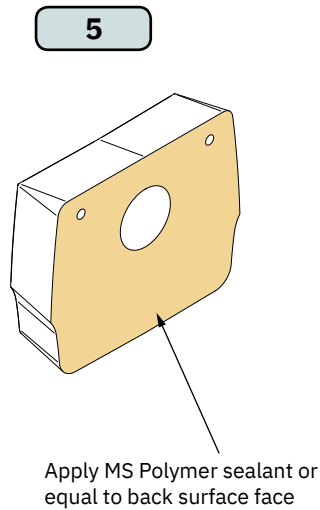
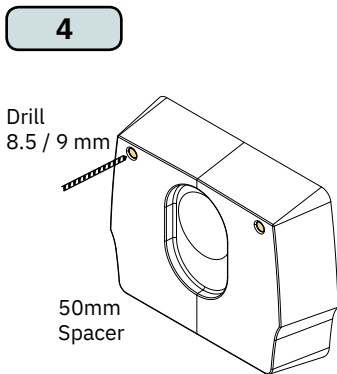

IMPORTANT

The spacer and hull have different hole diameters for the support bolts. This is to allow the compression rings to be inserted into the hull only.

The spacer and hull for the main tube have the same hole diameter so compression rings can be inserted for the total length of the hole.

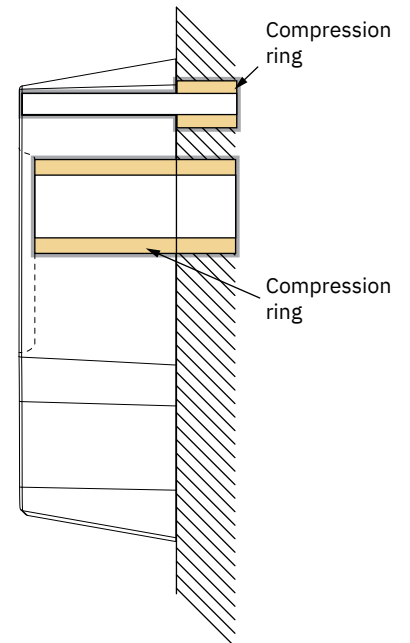

MG_0262

Before installations all aluminium parts of the thruster must be coated with an epoxy primer before antifouling process.

1. Define the location to install the thruster. **(NB: Ensure the thruster does not protrude past the transom profile on any side and there is no obstruction to the thrusters water flow. Also, check internally the thruster will not obstruct any objects. Ensure cables internally do not obstruct any objects. Do not place cables or control box close to high heat radiating parts EG. Turbo/ exhaust manifolds etc.)** Roughly estimate the location of the control box inside the vessel. Plan for the control box to be installed above the waterline.
2. Mark the locations of the three drill holes using the defined measurements in this manual or from a template. **(NB: Maximum hull thickness is 50mm including optional spacer or 150mm for extended hull thickness models.)**
3. Drill main hole, then two support bolt holes. Clean the area from dust for installation of the thruster.
4. Install a bolt and washer to ensure top bolts contact surface area is level with the main tube. Temporarily place the thruster through the holes to ensure correct fitting. Using the cable leads from the thruster define the final location within the vessel for the installation of the control box. **(NB: If using a spacer the support bolt and washer are not required.)**
5. Check the length of the compression rings. Compression rings must be longer than hull thickness to allow for compression **(NB: Cut compression sealants to length top achieve 10% compression.)**

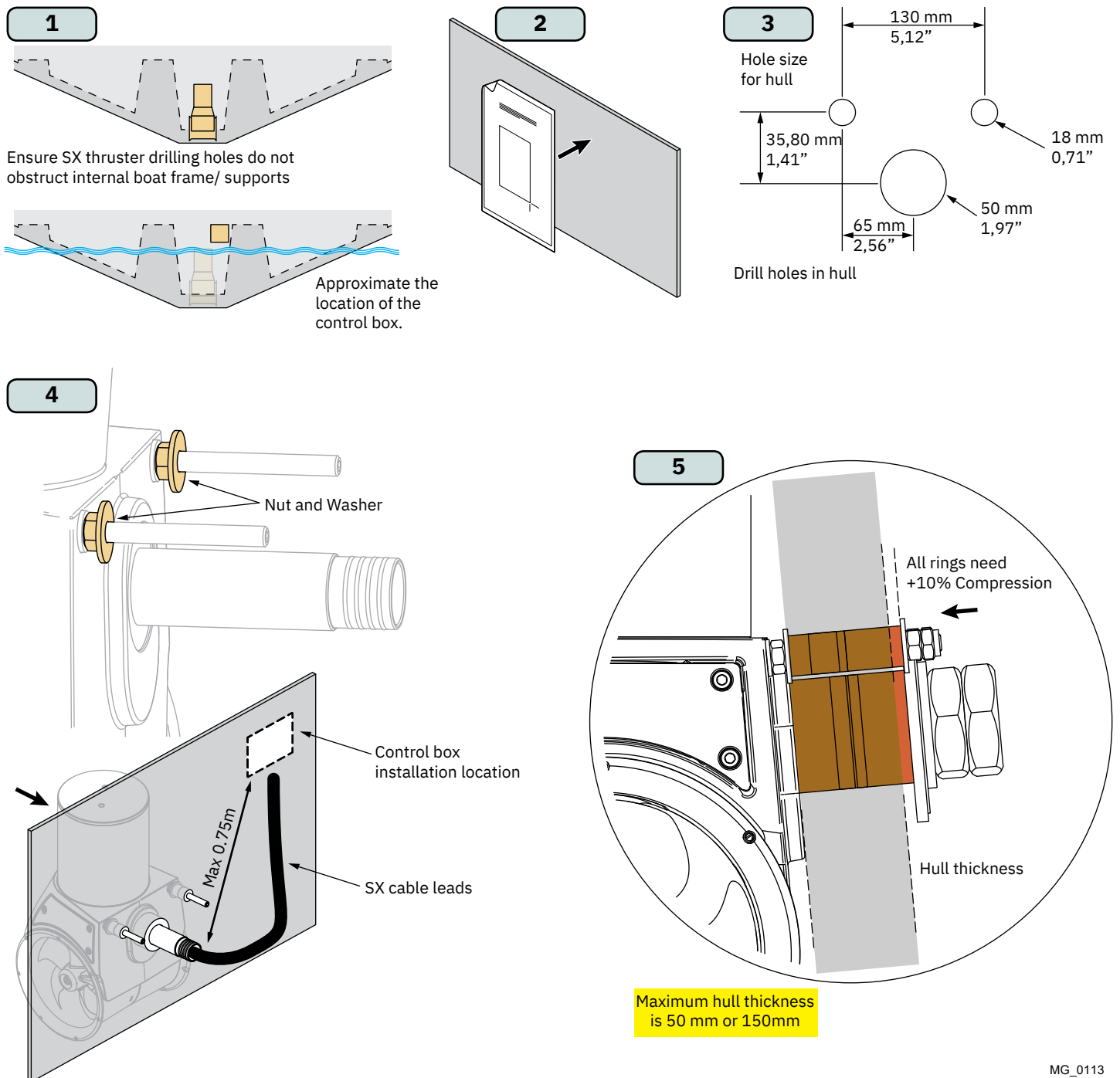

6. The thruster assembly must sit flush on the transom. Grind and sand the area if required to ensure a secure fit. **(NB: Use caution when grinding/sanding surfaces as to not remove too much fibreglass.)**
7. Ensure both bolts and washers to the support bars on the thruster are attached.
Prepare surface according to sealant supplier specification:
 - the inside surface of the cut-out holes on the hull.
 - To the surface of the washer to the thread and
 - in the recess of the main tube to the thread.
 - 1cm deep inside all compression ring.
 place all compression rings to bolt threads. **(NB: Ensure ample sealant (MS Polymer) around the bolts and centre tube for a watertight fitting.)**
8. Insert the thruster with compression rings into the hole.
9. Fasten the thruster

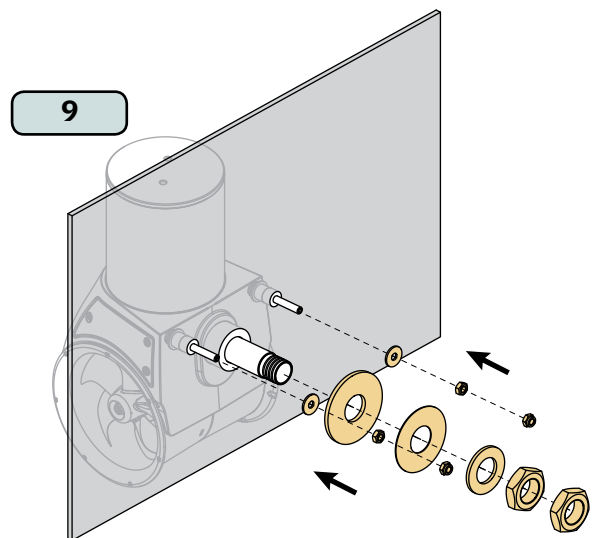
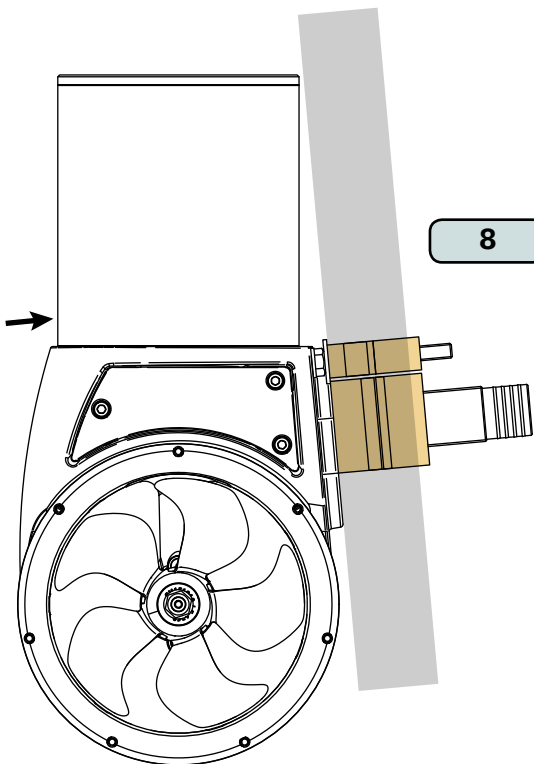
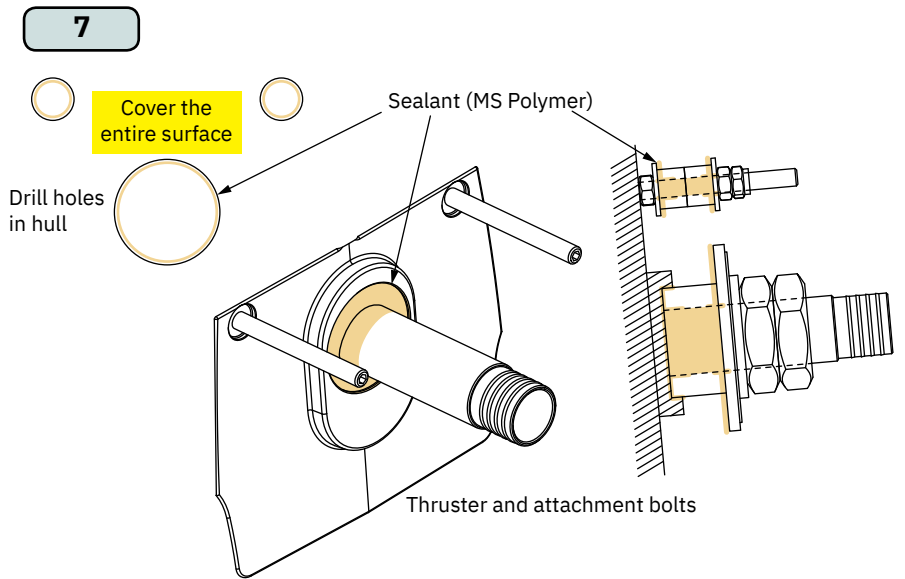
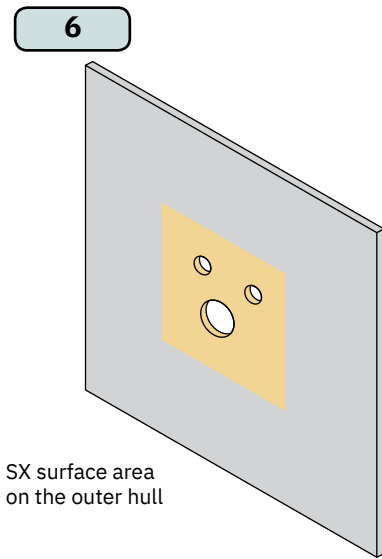

1. Centre the drive pin and Insert the propeller onto the shaft spine. Rotate the propeller until the drive pin aligns with the internal slot in the propeller.
2. Insert the washer to the end of the shaft spline. Tighten with the propeller lock-nut.
3. Apply anti fouling to the gear leg and propeller. Do not apply anti fouling to any rubber elements of the gear leg or anodes.

WARNING

Do not use abrasive tools damaging the existing Epoxy coating when preparing for antifouling paint.

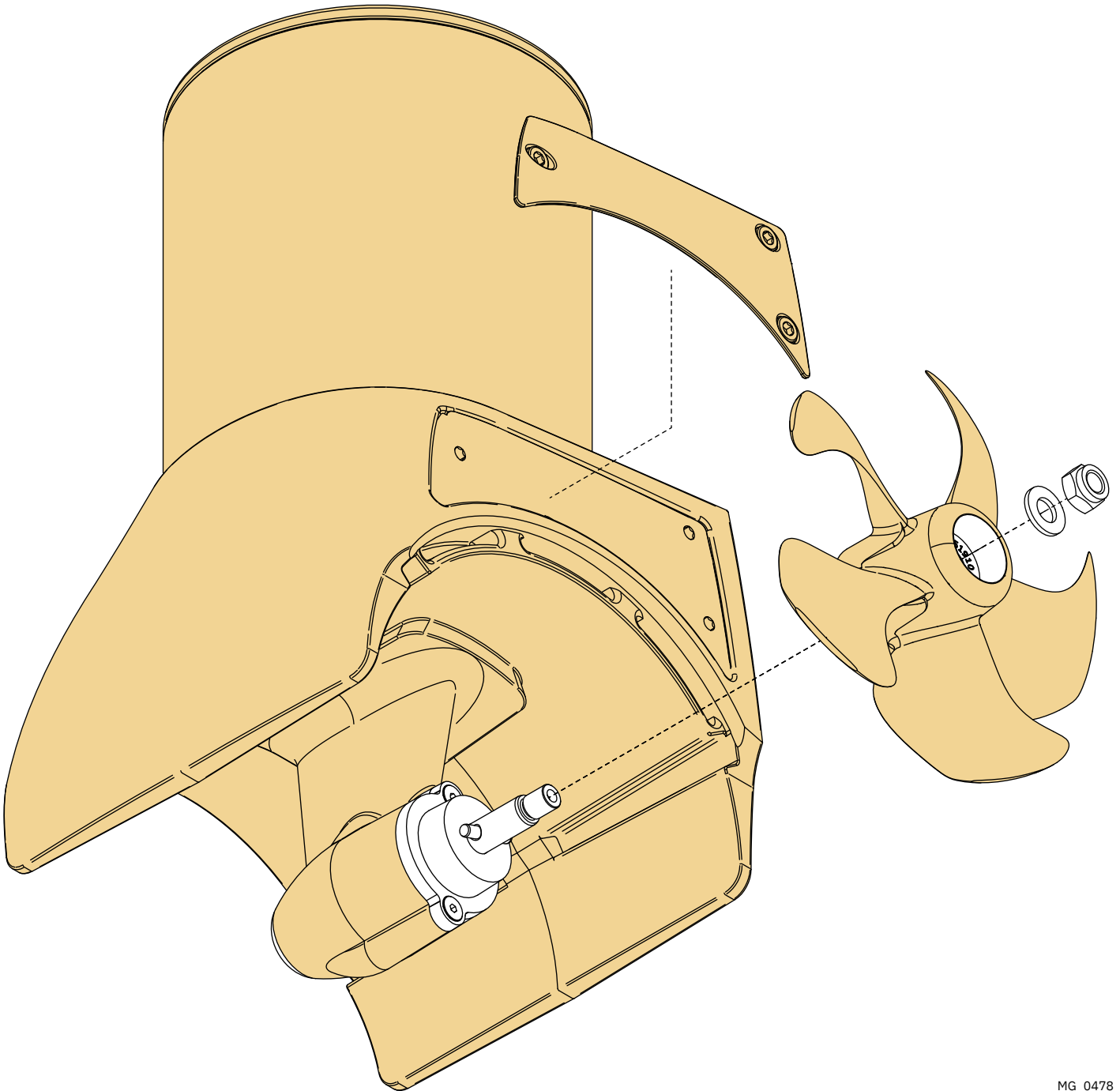

MG_0478

1. Attach the cowls or grids with included bolts. **(NB: If installation of the cowls ensure the appropriate twist of the cowl to direct water away from obstacles)**

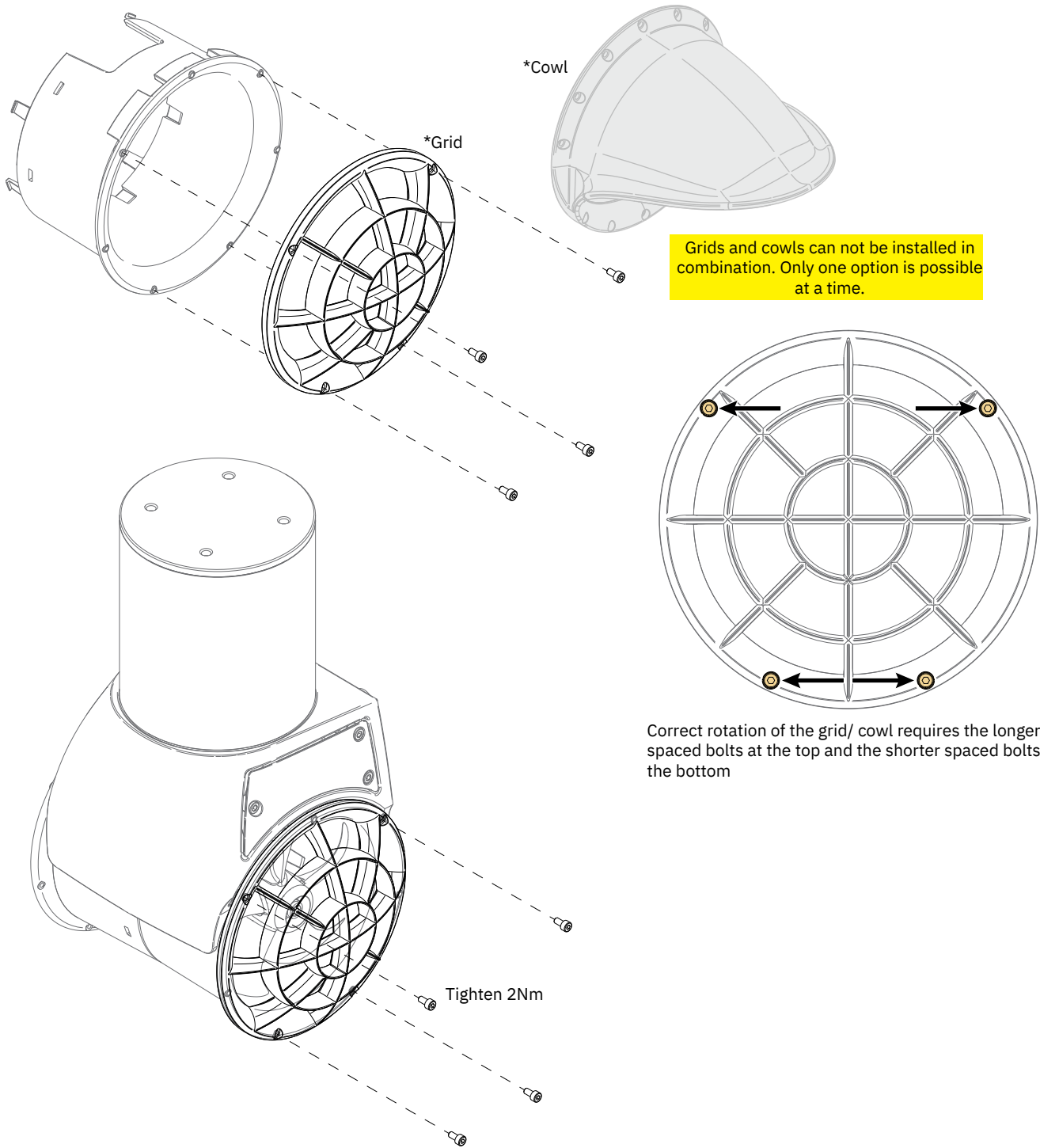

MG_0145

1. Plan the location of all electrical components before starting with the electrical installation. Main electrical components will typically consist of battery, fuse, main switch, Proportional Power Controller (PPC) and Control Box, see Wiring Diagram chapter for an overview.

For safety reasons it is always recommended to install a fuse and a main switch on the power cable and as close as possible to the positive battery pole. Distance between battery and fuse should be less than 1 meter. The main switch must be installed such that is easily accessible to disconnect the thruster when not on-board or in the case of an emergency. Sleipner offers both manual main switches and Automatic Main Switches (AMS). Sleipner AMS is controlled by the control panel in addition to the option of manual operation. Turning on the control panel does also turn on the automatic main switch. When the control panel is turned off the automatic main switch is also turned off. This ensures that the control electronics and motor is only energized when the control panel is turned on. Sleipner offers AMS supporting either S-Link or ON/OFF control panels. Ensure to select a main switch with voltage and current ratings according to the specifications of the chosen thruster motor. Note that the AMS requires separate power supply which should be protected by a dedicated fuse.

For installations which requires ignition protected equipment ensure to use ignition protected fuse and main switch. Ensure to follow your national regulations.

2. Estimate the total length of the power cables to determine the recommended cross section. The total power cable length is defined as the distances from the positive battery pole, via fuse, main switch and PPC to the Control Box and all the way back to the negative battery pole. Compromising the cable sections named B+, M- and B- on the drawing in the Wiring Diagram chapter.
3. Find the recommended power cable cross section for you installation by using the estimated total power cable length and the table shown in Electrical Reference Guide chapter. Note that maximum cross section that fits through the grommet of the Control Box is 70mm². Maximum cross section that fits with the power cable terminal inside the Control Box is 50mm². If a 70mm² cable is used some of the wire strands must be cut off to fit the cable inside the terminal. If recommended cross section exceeds 70mm² it is recommended to use as short as possible cables between PPC and Control Box with maximum 70mm² cross section. The recommended cross section or larger should then be used for the rest of the power cables.
4. Find the recommended fuse rating by using the table shown in Electrical Reference Guide chapter. Use slow blow rated fuses to hold stated nominal current for minimum 5 minutes.
5. Select appropriate dimensioned battery with Cold Cranking Amps (CCA) according to according to recommendations in Electrical Reference Guide chapter. Battery voltage must be compliant with the voltage rating of the thruster motor and control circuitry. Capacity and rated discharge current of battery should be according to rated nominal current drawn and typical duty cycle for thruster operation. Nominal current drawn is listed in Electrical Reference Guide chapter. The actual voltage at the motor while running the thruster determines the motor RPM and thrust. Cable losses can reduce the voltage level and result in reduced thrust. Use larger cable cross section and high-capacity battery for improved performance.
6. Install the Control Box according to instructions in Control Box Installation chapter.
7. Install the control panel according to instructions in the installation manual of the selected Control Panel.
8. Install the battery, fuse, main switch and wiring according to instructions in Wiring Diagram chapter and installation manual of selected fuse and main switch.

WARNING

Check the following with the main switch is set to off. After all electrical connections have been completed check with an ohm meter that there is no electrical connection between

- 1. electro-motor flange and the positive terminal on the motor**
- 2. electro-motor flange and the battery negative terminal on the motor**

(If unsure contact skilled personnel.)

Electrical Reference Guide

Model Size	System Voltage	Nominal current draw	Min. battery CCA	Rec. fuse	Cross Section Guide for Power Cables												
					Unit	<7m total + & -		7-14m total + & -		15-21m total + & -		22-28m total + & -		28-35m total + & -		36-45m total + & -	
						Min.	Rec.	Min.	Rec.	Min.	Rec.	Min.	Rec.	Min.	Rec.	Min.	Rec.
35/140	12V	245 A	DIN: 200 SAE: 380 EN: 330	ANL 150	mm ²	35	50	50	70	70	95	95	120	120	2 x 70	2 x 70	2 x 95
					AWG	2	1/0	1/0	2/0	2/0	3/0	3/0	4/0	4/0	2 x 2/0	2 x 2/0	2 x 3/0
50/140S	12V	370 A	DIN: 350 SAE: 665 EN: 600	ANL 325	mm ²	50	50	70	95	120	2 x 70	2 x 70	2 x 95	2 x 95	2 x 120	2 x 120	2 x 120
					AWG	1/0	1/0	2/0	3/0	4/0	2 x 2/0	2 x 2/0	2 x 3/0	2 x 3/0	2 x 4/0	2 x 4/0	2 x 4/0

Follow the below steps to install the Control Box. Additional installation details can be found in the corresponding graphics.

1. Pull the blue SX Thruster Hose around the cable harness coming out of the SX Thruster. Fasten the hose clamp.
2. Define the location to install the Control Box. It can be mounted in any orientation, preferably with cables facing down. The control box must be positioned within 0.75 meters from the thruster attachment bolts. Ensure that the SX Thruster Hose will not obstruct any objects and not placed near any object that radiate high temperatures.
3. Mark the locations of the four drill holes and drill the holes. Ensure that the back wall where the Control Box is to be mounted have sufficient thickness and strength.

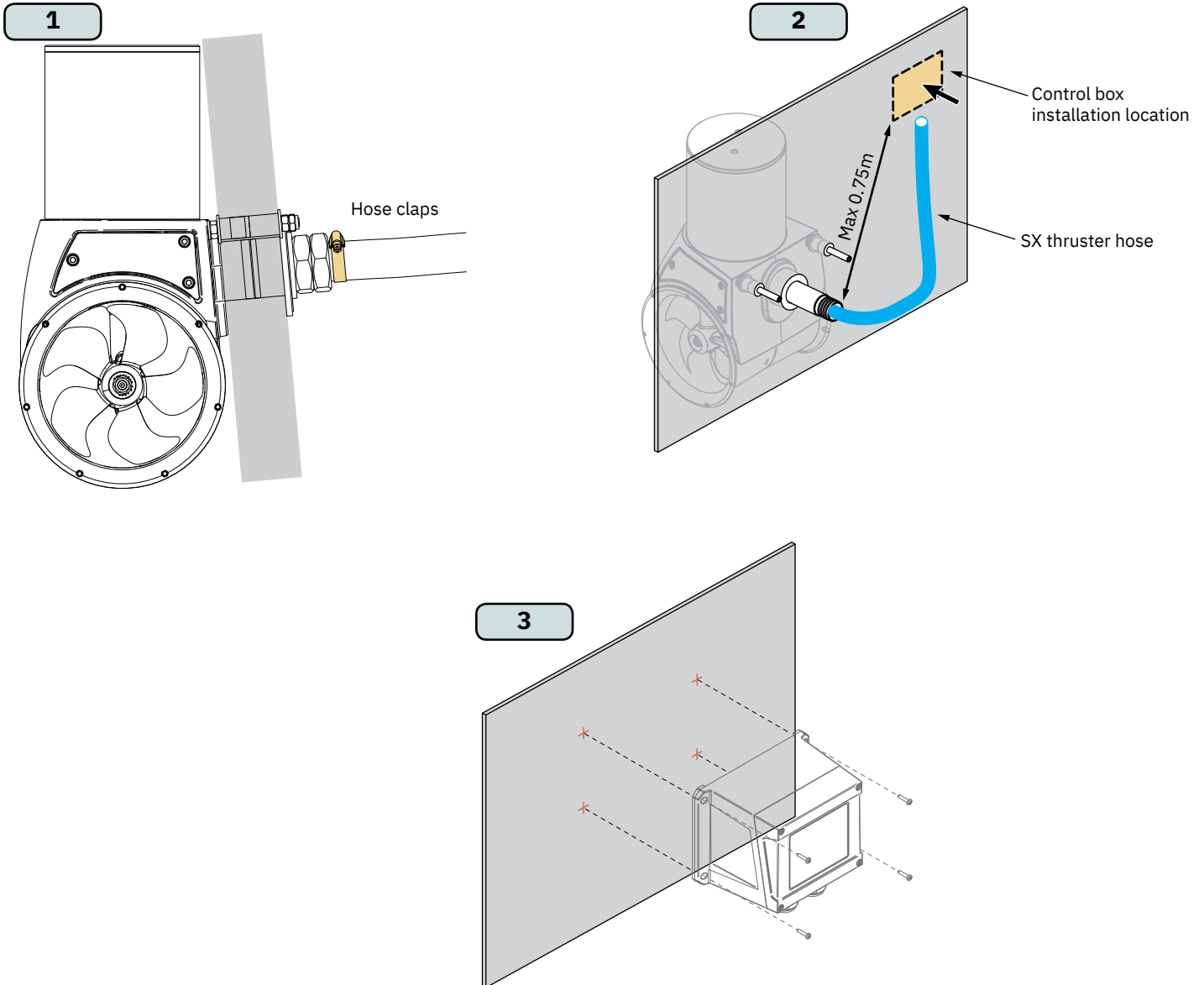

4. Follow the cable marking and fasten motor power cables coming from the SX Thruster in the control box. The motor power cables are marked A1 and A2 and should be fastened to the terminal with corresponding marking. Place the ring cable lug connected to the white wire between the lug of the motor power cable and the nut. Fasten the nut with recommended torque. Ensure that the ring cable lug is kept at same terminal as originally placed.
 - Insert the B+ and M- power cables into the grommet or external connectors as shown in figure below. Fasten the power cables to the terminals with recommended torque.
 - Connect the Temp Switch and NTC connector
5. Tighten hose clamp on Control Box.
6. Fasten the control box to the hull.

IMPORTANT

It is the installers full responsibility to follow instructions and ensure total Ignition Protection.

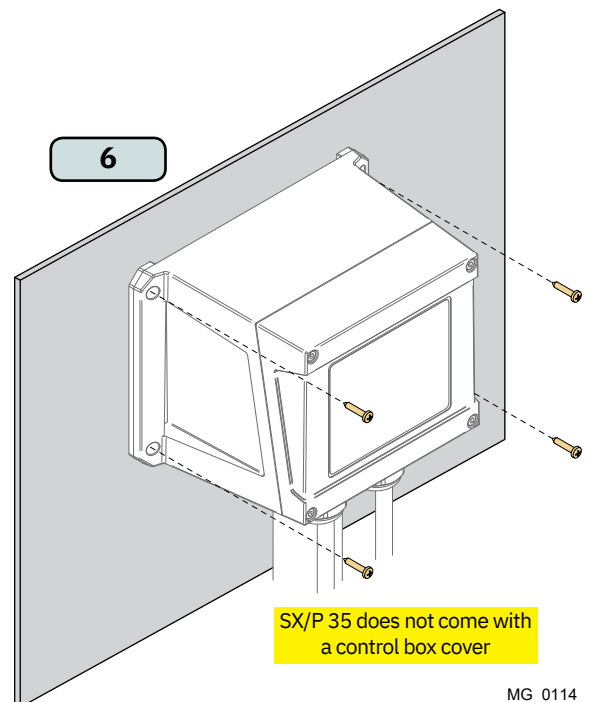
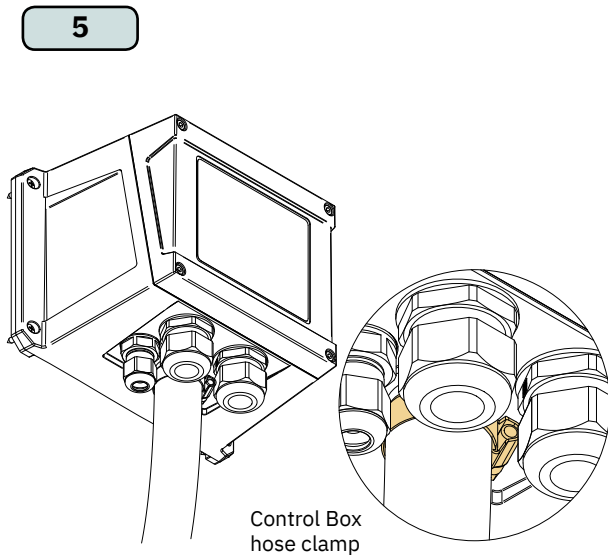
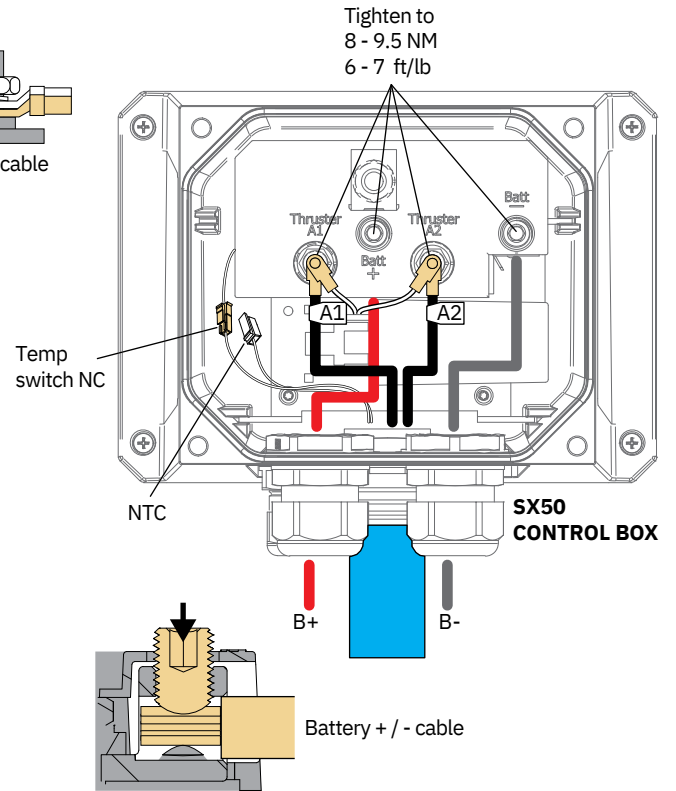
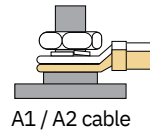
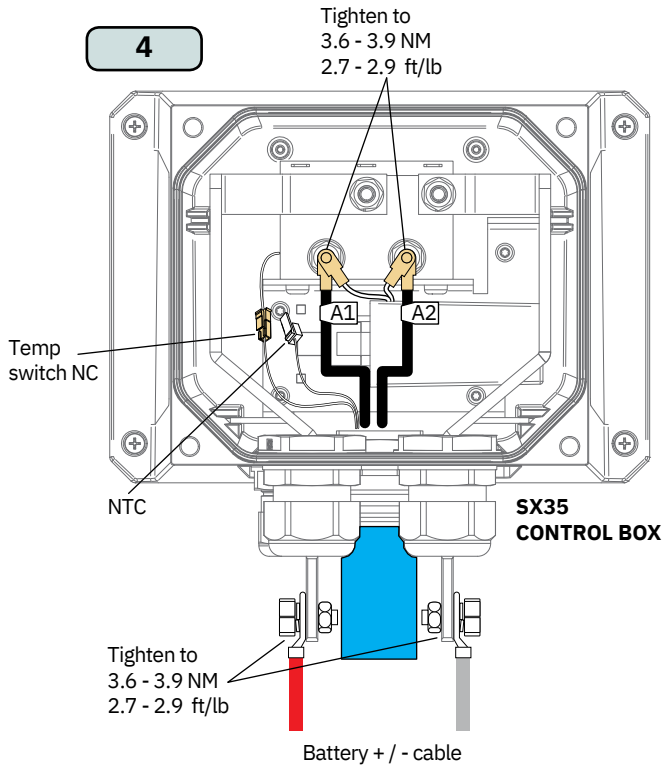

Visual Wiring Diagram

Refer to your control panel manual for detailed information on connecting the SX system to your control device

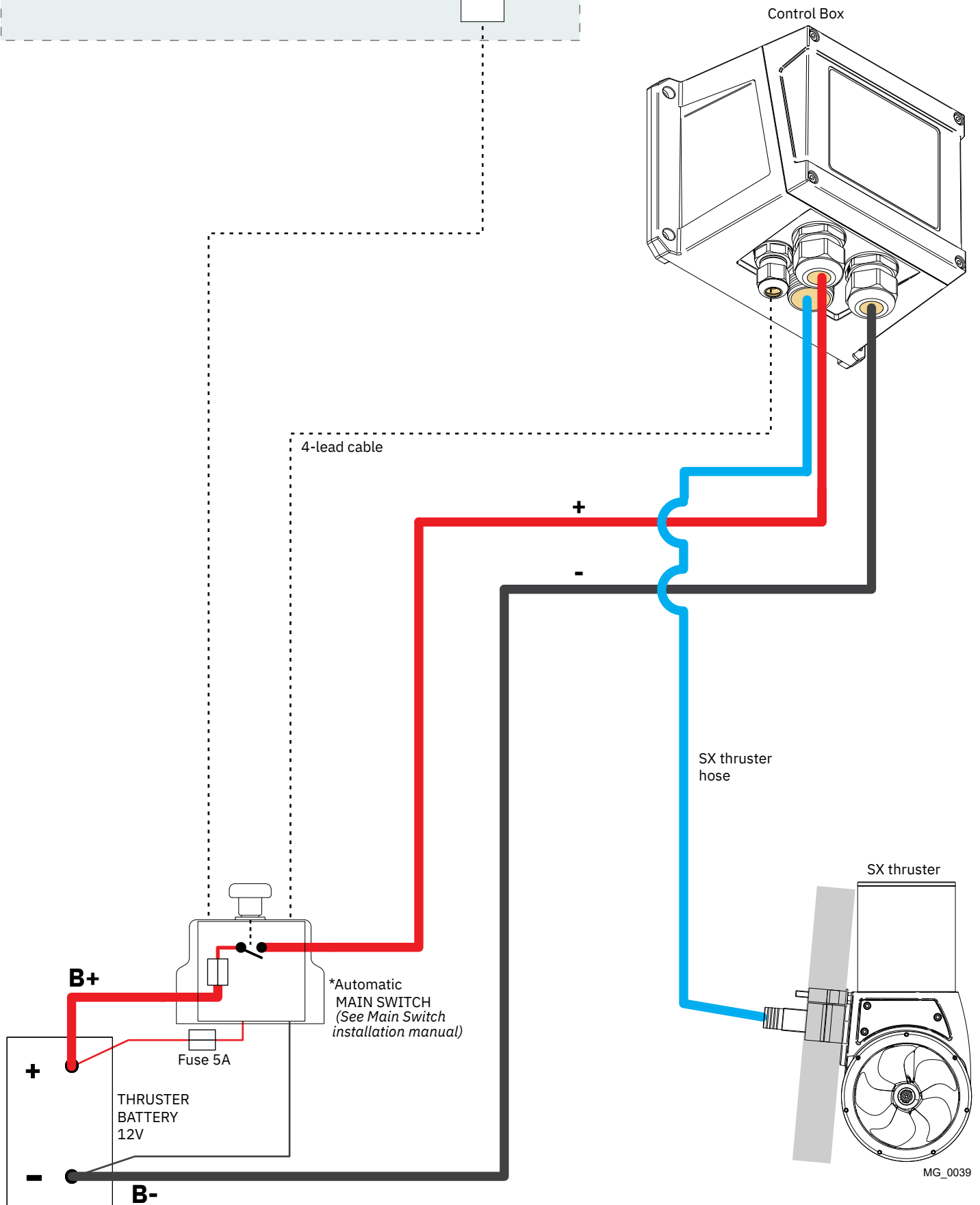
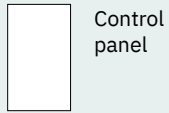

*Automatic Main Switch can be replaced by a fuse holder and manual main switch.

For **Control Panel** installation please refer to the Installation Guide accompanying the control panel to be installed.



- Propeller is fastened correctly to the shaft.
- Propeller turns freely in tunnel.
- Primer and anti-fouling have been applied to the gear house and propeller but NOT on the anode or the gear house lid where the propeller is fastened. **(NB: Do not use abrasive tools damaging the existing Epoxy coating when preparing for antifouling paint.)**
- Correct drive direction as per control panel.
- The bolts holding the thruster to the hull are tightened correctly.
- All electrical connections are clean, dry and tight, and the correct cable, fuse and main switch size.
- No water leakage around hull penetrated studs
- Check that there is no electrical connection between the electro motor body and positive terminal on the motor, and between the electro motor body and the negative (A1) terminal on the motor with an ohm meter.

The thruster has been installed as per the instructions in this manual and all points in checklist above have been controlled.

Signed:

Date:

Extra pre-delivery tests by installer / yard who does not use other quality control systems !

Thruster type:

Serial number:.....

Date of delivery:.....

Correct drive direction as per control panel:

The compartment for the thruster has been isolated from general bilge water and has no obvious or suspected risks for flooding:

.....
.....
.....

Other comments by installer:

.....
.....
.....

Find your local professional dealer from our certified worldwide network for expert service and support. visit our website www.sleipnergrouper.com/support

Product Spare Parts and Additional Resources

For additional supporting documentation, we advise you to visit our website www.sleipnergrouper.com and find your Sleipner product.

Warranty statement

1. Sleipner Motor AS (The “Warrantor”) warrants that the equipment (parts, materials, and embedded software of products) manufactured by the Warrantor is free from defects in workmanship and materials for purpose for which the equipment is intended and under normal use and maintenance service (the “Warranty”).
2. This Warranty is in effect for two years (Leisure Use) or one year (Commercial and other Non-leisure Use) from the date of delivery/purchase by the end user, with the following exceptions;
 - (a) For demonstration vessels, or vessels kept on the water, the dealer is considered as the end user from 6 months after their launch of the vessel;
 - (b) The warranty period starts no later than 18 months after the first launch of the vessel.
 Please note that the boat manufacturer and dealer must pay particular attention to correct maintenance and service both by the products manuals as well as general good practice for the location the boat is kept in the period the boat is in their care. In cases where the 6 and 18 months grace periods for boat builders and dealers are passed, it is possible to obtain a full warranty upon inspection and approval of the warrantor or such representative.
3. Certain parts, classified as wearable or service parts, are not covered by the warranty. A failure to follow the required maintenance and service work as described in the product manual render all warranty on parts or components directly or indirectly affected by this void. Please also note that for some parts, time is also a factor separately from actual operational hours.
4. This Warranty is transferable and covers the equipment for the specified warranty period.
5. The warranty does not apply to defects or damages caused by faulty installation or hook-up, abuse or misuse of the equipment including exposure to excessive heat, salt or fresh water spray, or water immersion except for equipment specifically designed as waterproof.
6. In case the equipment seems to be defective, the warranty holder (the “Claimant”) must do the following to make a claim:
 - (a) Contact the dealer or service centre where the equipment was purchased and make the claim. Alternatively, the Claimant can make the claim to a dealer or service centre found at www.sleipnergrouper.com. The Claimant must present a detailed written statement of the nature and circumstances of the defect, to the best of the Claimant’s knowledge, including product identification and serial nbr., the date and place of purchase and the name and address of the installer. Proof of purchase date should be included with the claim, to verify that the warranty period has not expired;
 - (b) Make the equipment available for troubleshooting and repair, with direct and workable access, including dismantling of furnishings or similar, if any, either at the premises of the Warrantor or an authorised service representative approved by the Warrantor. Equipment can only be returned to the Warrantor or an authorised service representative for repair following a pre-approval by the Warrantor’s Help Desk and if so, with the Return Authorisation Number visible postage/shipping prepaid and at the expense of the Claimant.
7. Examination and handling of the warranty claim:
 - (a) If upon the Warrantor’s or authorised service Representative’s examination, the defect is determined to result from defective material or workmanship in the warranty period, the equipment will be repaired or replaced at the Warrantor’s option without charge, and returned to the Purchaser at the Warrantor’s expense. If, on the other hand, the claim is determined to result from circumstances such as described in section 4 above or a result of wear and tear exceeding that for which the equipment is intended (e.g. commercial use of equipment intended for leisure use), the costs for the troubleshooting and repair shall be borne by the Claimant;
 - (b) No refund of the purchase price will be granted to the Claimant, unless the Warrantor is unable to remedy the defect after having a reasonable number of opportunities to do so. In the event that attempts to remedy the defect have failed, the Claimant may claim a refund of the purchase price, provided that the Claimant submits a statement in writing from a professional boating equipment supplier that the installation instructions of the Installation and Operation Manual have been complied with and that the defect remains.
8. Warranty service shall be performed only by the Warrantor, or an authorised service representative, and any attempt to remedy the defect by anyone else shall render this warranty void.
9. No other warranty is given beyond those described above, implied or otherwise, including any implied warranty of merchantability, fitness for a particular purpose other than the purpose for which the equipment is intended, and any other obligations on the part of the Warrantor or its employees and representatives.
10. There shall be no responsibility or liability whatsoever on the part of the Warrantor or its employees and representatives based on this Warranty for injury to any person or persons, or damage to property, loss of income or profit, or any other incidental, consequential or resulting damage or cost claimed to have been incurred through the use or sale of the equipment, including any possible failure or malfunction of the equipment or damages arising from collision with other vessels or objects.
11. This warranty gives you specific legal rights, and you may also have other rights which vary from country to country.

Patents

At Sleipner we continually reinvest to develop and offer the latest technology in marine advancements. To see the many unique designs we have patented visit our website www.sleipnergrouper.com/patents

© **Sleipner Group**, All rights reserved
The information given in the document was right at the time it was published. However, Sleipner Group cannot accept liability for any inaccuracies or omissions it may contain. Continuous product improvement may change the product specifications without notice. Therefore, Sleipner Group cannot accept liability for any possible differences between product and document.

Register your product and learn more at www.sleipnergroun.com



SLEIPNER GROUP

P.O. Box 519

N-1612 Fredrikstad

Norway

www.sleipnergroun.com

Made in Norway

